

Solutions Manual for
Thermodynamics: An Engineering Approach
Seventh Edition
Yunus A. Cengel, Michael A. Boles
McGraw-Hill, 2011

Chapter 6

THE SECOND LAW OF THERMODYNAMICS

PROPRIETARY AND CONFIDENTIAL

This Manual is the proprietary property of The McGraw-Hill Companies, Inc. (“McGraw-Hill”) and protected by copyright and other state and federal laws. By opening and using this Manual the user agrees to the following restrictions, and if the recipient does not agree to these restrictions, the Manual should be promptly returned unopened to McGraw-Hill: **This Manual is being provided only to authorized professors and instructors for use in preparing for the classes using the affiliated textbook. No other use or distribution of this Manual is permitted. This Manual may not be sold and may not be distributed to or used by any student or other third party. No part of this Manual may be reproduced, displayed or distributed in any form or by any means, electronic or otherwise, without the prior written permission of McGraw-Hill.**

The Second Law of Thermodynamics and Thermal Energy Reservoirs

6-1C Transferring 5 kWh of heat to an electric resistance wire and producing 5 kWh of electricity.

6-2C An electric resistance heater which consumes 5 kWh of electricity and supplies 6 kWh of heat to a room.

6-3C Transferring 5 kWh of heat to an electric resistance wire and producing 6 kWh of electricity.

6-4C No. Heat cannot flow from a low-temperature medium to a higher temperature medium.

6-5C A thermal-energy reservoir is a body that can supply or absorb finite quantities of heat isothermally. Some examples are the oceans, the lakes, and the atmosphere.

6-6C Yes. Because the temperature of the oven remains constant no matter how much heat is transferred to the potatoes.

6-7C The surrounding air in the room that houses the TV set.

Heat Engines and Thermal Efficiency

6-8C No. Such an engine violates the Kelvin-Planck statement of the second law of thermodynamics.

6-9C Heat engines are cyclic devices that receive heat from a source, convert some of it to work, and reject the rest to a sink.

6-10C No. Because 100% of the work can be converted to heat.

6-11C It is expressed as "No heat engine can exchange heat with a single reservoir, and produce an equivalent amount of work".

6-12C (a) No, (b) Yes. According to the second law, no heat engine can have an efficiency of 100%.

6-13C No. Such an engine violates the Kelvin-Planck statement of the second law of thermodynamics.

6-14C No. The Kelvin-Planck limitation applies only to heat engines; engines that receive heat and convert some of it to work.

6-15C Method (b). With the heating element in the water, heat losses to the surrounding air are minimized, and thus the desired heating can be achieved with less electrical energy input.

6-16E The rate of heat input and thermal efficiency of a heat engine are given. The power output of the heat engine is to be determined.

Assumptions 1 The plant operates steadily. 2 Heat losses from the working fluid at the pipes and other components are negligible.

Analysis Applying the definition of the thermal efficiency to the heat engine,

$$\begin{aligned}\dot{W}_{\text{net}} &= \eta_{\text{th}} \dot{Q}_H \\ &= (0.4)(3 \times 10^4 \text{ Btu/h}) \left(\frac{1 \text{ hp}}{2544.5 \text{ Btu/h}} \right) \\ &= \mathbf{4.72 \text{ hp}}\end{aligned}$$

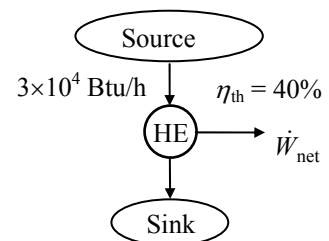

6-17 The power output and thermal efficiency of a heat engine are given. The rate of heat input is to be determined.

Assumptions 1 The plant operates steadily. 2 Heat losses from the working fluid at the pipes and other components are negligible.

Analysis Applying the definition of the thermal efficiency to the heat engine,

$$\dot{Q}_H = \frac{\dot{W}_{\text{net}}}{\eta_{\text{th}}} = \frac{30 \text{ hp}}{0.4} \left(\frac{0.7457 \text{ kJ/s}}{1 \text{ hp}} \right) = \mathbf{55.9 \text{ kJ/s}}$$

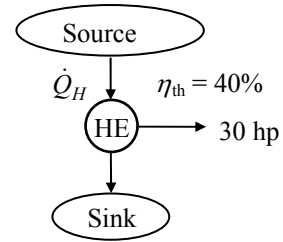

6-18 The power output and thermal efficiency of a power plant are given. The rate of heat rejection is to be determined, and the result is to be compared to the actual case in practice.

Assumptions 1 The plant operates steadily. 2 Heat losses from the working fluid at the pipes and other components are negligible.

Analysis The rate of heat supply to the power plant is determined from the thermal efficiency relation,

$$\dot{Q}_H = \frac{\dot{W}_{\text{net,out}}}{\eta_{\text{th}}} = \frac{600 \text{ MW}}{0.4} = 1500 \text{ MW}$$

The rate of heat transfer to the river water is determined from the first law relation for a heat engine,

$$\dot{Q}_L = \dot{Q}_H - \dot{W}_{\text{net,out}} = 1500 - 600 = \mathbf{900 \text{ MW}}$$

In reality the amount of heat rejected to the river will be **lower** since part of the heat will be lost to the surrounding air from the working fluid as it passes through the pipes and other components.

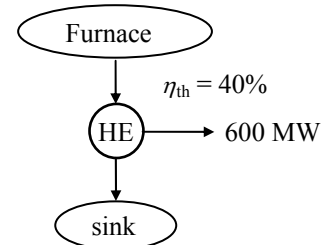

6-19 The work output and heat input of a heat engine are given. The heat rejection is to be determined.

Assumptions 1 The plant operates steadily. 2 Heat losses from the working fluid at the pipes and other components are negligible.

Analysis Applying the first law to the heat engine gives

$$Q_L = Q_H - W_{\text{net}} = 700 \text{ kJ} - 250 \text{ kJ} = \mathbf{450 \text{ kJ}}$$

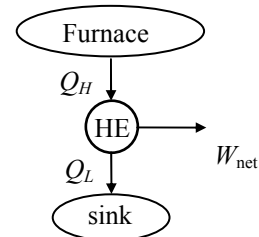

6-20 The heat rejection and thermal efficiency of a heat engine are given. The heat input to the engine is to be determined.

Assumptions **1** The plant operates steadily. **2** Heat losses from the working fluid at the pipes and other components are negligible.

Analysis According to the definition of the thermal efficiency as applied to the heat engine,

$$w_{\text{net}} = \eta_{\text{th}} q_H$$

$$q_H - q_L = \eta_{\text{th}} q_H$$

which when rearranged gives

$$q_H = \frac{q_L}{1 - \eta_{\text{th}}} = \frac{1000 \text{ kJ/kg}}{1 - 0.4} = \mathbf{1667 \text{ kJ/kg}}$$

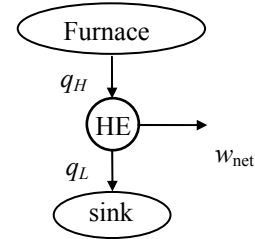

6-21 The power output and fuel consumption rate of a power plant are given. The thermal efficiency is to be determined.

Assumptions The plant operates steadily.

Properties The heating value of coal is given to be 30,000 kJ/kg.

Analysis The rate of heat supply to this power plant is

$$\begin{aligned} \dot{Q}_H &= \dot{m}_{\text{coal}} q_{\text{HV,coal}} \\ &= (60,000 \text{ kg/h})(30,000 \text{ kJ/kg}) = 1.8 \times 10^9 \text{ kJ/h} \\ &= 500 \text{ MW} \end{aligned}$$

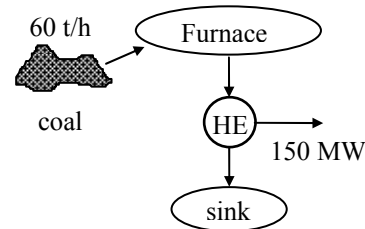

Then the thermal efficiency of the plant becomes

$$\eta_{\text{th}} = \frac{\dot{W}_{\text{net,out}}}{\dot{Q}_H} = \frac{150 \text{ MW}}{500 \text{ MW}} = 0.300 = \mathbf{30.0\%}$$

6-22 The power output and fuel consumption rate of a car engine are given. The thermal efficiency of the engine is to be determined.

Assumptions The car operates steadily.

Properties The heating value of the fuel is given to be 44,000 kJ/kg.

Analysis The mass consumption rate of the fuel is

$$\dot{m}_{\text{fuel}} = (\rho \dot{V})_{\text{fuel}} = (0.8 \text{ kg/L})(22 \text{ L/h}) = 17.6 \text{ kg/h}$$

The rate of heat supply to the car is

$$\begin{aligned} \dot{Q}_H &= \dot{m}_{\text{coal}} q_{\text{HV,coal}} \\ &= (17.6 \text{ kg/h})(44,000 \text{ kJ/kg}) \\ &= 774,400 \text{ kJ/h} = 215.1 \text{ kW} \end{aligned}$$

Then the thermal efficiency of the car becomes

$$\eta_{\text{th}} = \frac{\dot{W}_{\text{net,out}}}{\dot{Q}_H} = \frac{55 \text{ kW}}{215.1 \text{ kW}} = 0.256 = \mathbf{25.6\%}$$

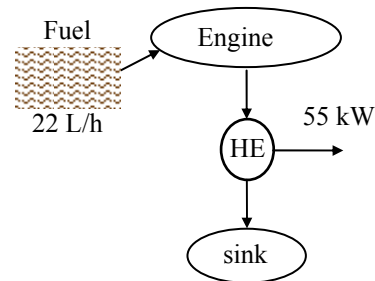

6-23 The United States produces about 51 percent of its electricity from coal at a conversion efficiency of about 34 percent. The amount of heat rejected by the coal-fired power plants per year is to be determined.

Analysis Noting that the conversion efficiency is 34%, the amount of heat rejected by the coal plants per year is

$$\begin{aligned} \eta_{\text{th}} &= \frac{W_{\text{coal}}}{Q_{\text{in}}} = \frac{W_{\text{coal}}}{Q_{\text{out}} + W_{\text{coal}}} \\ Q_{\text{out}} &= \frac{W_{\text{coal}}}{\eta_{\text{th}}} - W_{\text{coal}} \\ &= \frac{1.878 \times 10^{12} \text{ kWh}}{0.34} - 1.878 \times 10^{12} \text{ kWh} \\ &= \mathbf{3.646 \times 10^{12} \text{ kWh}} \end{aligned}$$

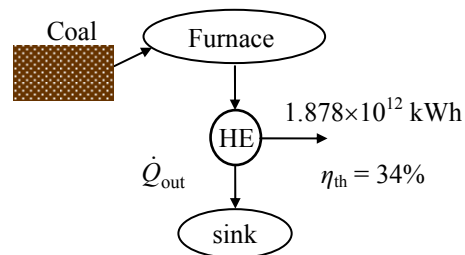

6-24 The projected power needs of the United States is to be met by building inexpensive but inefficient coal plants or by building expensive but efficient IGCC plants. The price of coal that will enable the IGCC plants to recover their cost difference from fuel savings in 5 years is to be determined.

Assumptions **1** Power is generated continuously by either plant at full capacity. **2** The time value of money (interest, inflation, etc.) is not considered.

Properties The heating value of the coal is given to be 28×10^6 kJ/ton.

Analysis For a power generation capacity of 150,000 MW, the construction costs of coal and IGCC plants and their difference are

$$\text{Construction cost}_{\text{coal}} = (150,000,000 \text{ kW})(\$1300/\text{kW}) = \$195 \times 10^9$$

$$\text{Construction cost}_{\text{IGCC}} = (150,000,000 \text{ kW})(\$1500/\text{kW}) = \$225 \times 10^9$$

$$\text{Construction cost difference} = \$225 \times 10^9 - \$195 \times 10^9 = \$30 \times 10^9$$

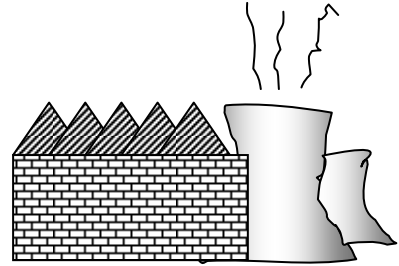

The amount of electricity produced by either plant in 5 years is

$$W_e = \dot{W} \Delta t = (150,000,000 \text{ kW})(5 \times 365 \times 24 \text{ h}) = 6.570 \times 10^{12} \text{ kWh}$$

The amount of fuel needed to generate a specified amount of power can be determined from

$$\eta = \frac{W_e}{Q_{\text{in}}} \rightarrow Q_{\text{in}} = \frac{W_e}{\eta} \quad \text{or} \quad m_{\text{fuel}} = \frac{Q_{\text{in}}}{\text{Heating value}} = \frac{W_e}{\eta(\text{Heating value})}$$

Then the amount of coal needed to generate this much electricity by each plant and their difference are

$$m_{\text{coal, coal plant}} = \frac{W_e}{\eta(\text{Heating value})} = \frac{6.570 \times 10^{12} \text{ kWh}}{(0.40)(28 \times 10^6 \text{ kJ/ton})} \left(\frac{3600 \text{ kJ}}{1 \text{ kWh}} \right) = 2.112 \times 10^9 \text{ tons}$$

$$m_{\text{coal, IGCC plant}} = \frac{W_e}{\eta(\text{Heating value})} = \frac{6.570 \times 10^{12} \text{ kWh}}{(0.48)(28 \times 10^6 \text{ kJ/ton})} \left(\frac{3600 \text{ kJ}}{1 \text{ kWh}} \right) = 1.760 \times 10^9 \text{ tons}$$

$$\Delta m_{\text{coal}} = m_{\text{coal, coal plant}} - m_{\text{coal, IGCC plant}} = 2.112 \times 10^9 - 1.760 \times 10^9 = 0.352 \times 10^9 \text{ tons}$$

For Δm_{coal} to pay for the construction cost difference of \$30 billion, the price of coal should be

$$\text{Unit cost of coal} = \frac{\text{Construction cost difference}}{\Delta m_{\text{coal}}} = \frac{\$30 \times 10^9}{0.352 \times 10^9 \text{ tons}} = \mathbf{\$85.2/\text{ton}}$$

Therefore, the IGCC plant becomes attractive when the price of coal is above \$85.2 per ton.



6-25 Problem 6-24 is reconsidered. The price of coal is to be investigated for varying simple payback periods, plant construction costs, and operating efficiency.

Analysis The problem is solved using EES, and the solution is given below.

"Given"

W_dot=15E7 [kW]
 Cost_coal=1300 [\$/kW]
 eta_coal=0.40
 Cost_IGCC=1500 [\$/kW]
 eta_IGCC=0.48
 HV_coal=28000 [kJ/kg]
 PaybackYears=5 [yr]

"Analysis"

time=PaybackYears*Convert(yr, h)
 ConstCost_coal=W_dot*Cost_coal
 ConstCost_IGCC=W_dot*Cost_IGCC
 ConstCostDif=ConstCost_IGCC-ConstCost_coal
 W_e=W_dot*time
 m_coal_coal=W_e/(eta_coal*HV_coal)*Convert(kWh, kJ)
 m_coal_IGCC=W_e/(eta_IGCC*HV_coal)*Convert(kWh, kJ)
 DELTAm_coal=m_coal_coal-m_coal_IGCC
 UnitCost_coal=ConstCostDif/DELTAm_coal*1000

| PaybackYears [yr] | UnitCost _{coal} [\$/ton] |
|----------------------|--------------------------------------|
| 1 | 426.2 |
| 2 | 213.1 |
| 3 | 142.1 |
| 4 | 106.5 |
| 5 | 85.24 |
| 6 | 71.03 |
| 7 | 60.88 |
| 8 | 53.27 |
| 9 | 47.35 |
| 10 | 42.62 |

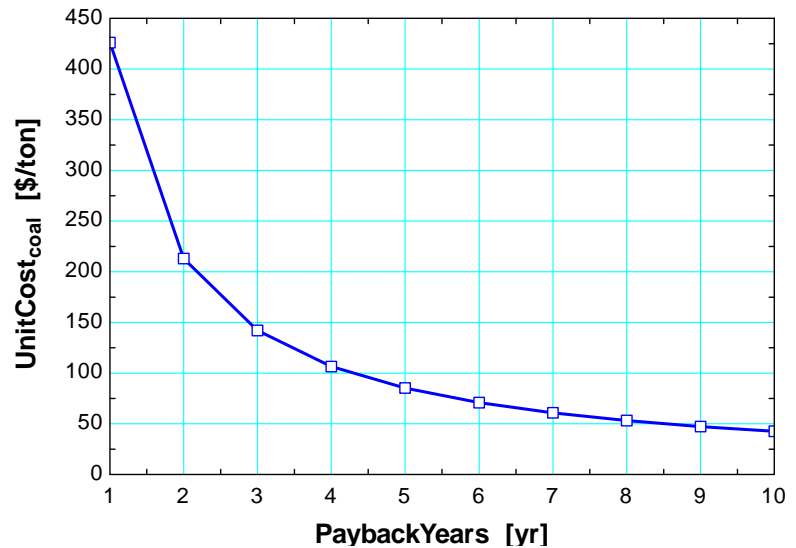

| η_{coal} | UnitCost _{coal} [\$/ton] |
|----------------------|-----------------------------------|
| 0.3 | 28.41 |
| 0.31 | 31.09 |
| 0.32 | 34.09 |
| 0.33 | 37.5 |
| 0.34 | 41.4 |
| 0.35 | 45.9 |
| 0.36 | 51.14 |
| 0.37 | 57.34 |
| 0.38 | 64.78 |
| 0.39 | 73.87 |
| 0.4 | 85.24 |
| 0.41 | 99.85 |
| 0.42 | 119.3 |
| 0.43 | 146.6 |
| 0.44 | 187.5 |
| 0.45 | 255.7 |

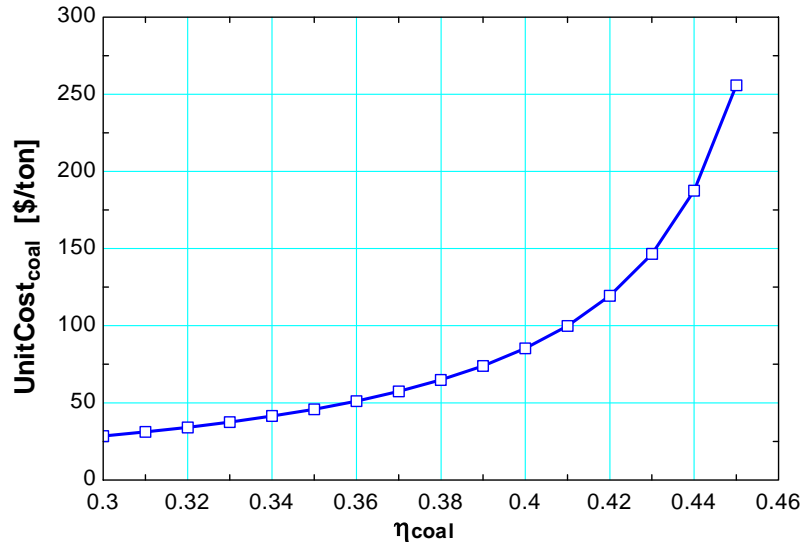

| Cost _{I GCC} [\$/kW] | UnitCost _{coal} [\$/ton] |
|-------------------------------|-----------------------------------|
| 1300 | 0 |
| 1400 | 42.62 |
| 1500 | 85.24 |
| 1600 | 127.9 |
| 1700 | 170.5 |
| 1800 | 213.1 |
| 1900 | 255.7 |
| 2000 | 298.3 |
| 2100 | 340.9 |
| 2200 | 383.6 |

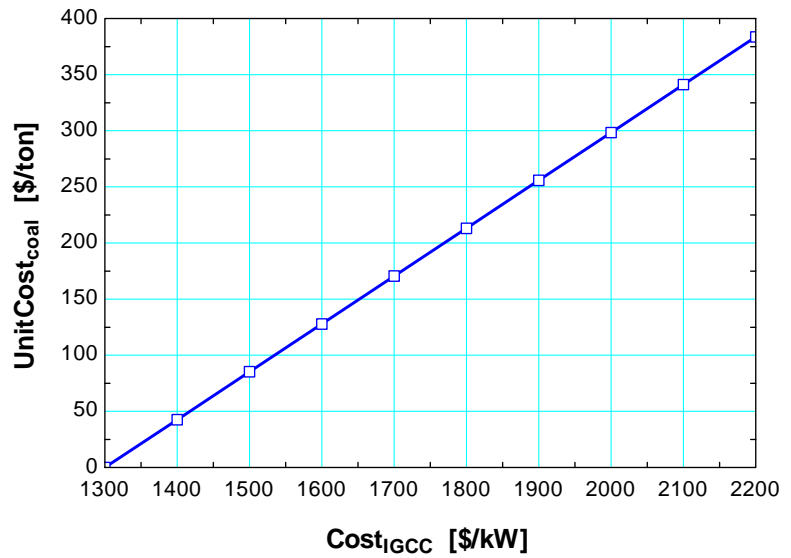

6-26 The projected power needs of the United States is to be met by building inexpensive but inefficient coal plants or by building expensive but efficient IGCC plants. The price of coal that will enable the IGCC plants to recover their cost difference from fuel savings in 3 years is to be determined.

Assumptions **1** Power is generated continuously by either plant at full capacity. **2** The time value of money (interest, inflation, etc.) is not considered.

Properties The heating value of the coal is given to be 28×10^6 kJ/ton.

Analysis For a power generation capacity of 150,000 MW, the construction costs of coal and IGCC plants and their difference are

$$\text{Construction cost}_{\text{coal}} = (150,000,000 \text{ kW})(\$1300/\text{kW}) = \$195 \times 10^9$$

$$\text{Construction cost}_{\text{IGCC}} = (150,000,000 \text{ kW})(\$1500/\text{kW}) = \$225 \times 10^9$$

$$\text{Construction cost difference} = \$225 \times 10^9 - \$195 \times 10^9 = \$30 \times 10^9$$

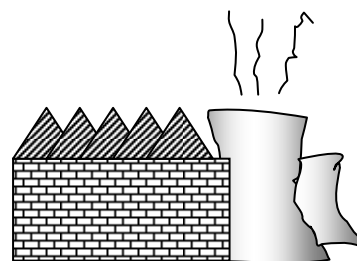

The amount of electricity produced by either plant in 3 years is

$$W_e = \dot{W} \Delta t = (150,000,000 \text{ kW})(3 \times 365 \times 24 \text{ h}) = 3.942 \times 10^{12} \text{ kWh}$$

The amount of fuel needed to generate a specified amount of power can be determined from

$$\eta = \frac{W_e}{Q_{\text{in}}} \rightarrow Q_{\text{in}} = \frac{W_e}{\eta} \quad \text{or} \quad m_{\text{fuel}} = \frac{Q_{\text{in}}}{\text{Heating value}} = \frac{W_e}{\eta(\text{Heating value})}$$

Then the amount of coal needed to generate this much electricity by each plant and their difference are

$$m_{\text{coal, coal plant}} = \frac{W_e}{\eta(\text{Heating value})} = \frac{3.942 \times 10^{12} \text{ kWh}}{(0.40)(28 \times 10^6 \text{ kJ/ton}) \left(\frac{3600 \text{ kJ}}{1 \text{ kWh}} \right)} = 1.267 \times 10^9 \text{ tons}$$

$$m_{\text{coal, IGCC plant}} = \frac{W_e}{\eta(\text{Heating value})} = \frac{3.942 \times 10^{12} \text{ kWh}}{(0.48)(28 \times 10^6 \text{ kJ/ton}) \left(\frac{3600 \text{ kJ}}{1 \text{ kWh}} \right)} = 1.055 \times 10^9 \text{ tons}$$

$$\Delta m_{\text{coal}} = m_{\text{coal, coal plant}} - m_{\text{coal, IGCC plant}} = 1.267 \times 10^9 - 1.055 \times 10^9 = 0.211 \times 10^9 \text{ tons}$$

For Δm_{coal} to pay for the construction cost difference of \$30 billion, the price of coal should be

$$\text{Unit cost of coal} = \frac{\text{Construction cost difference}}{\Delta m_{\text{coal}}} = \frac{\$30 \times 10^9}{0.211 \times 10^9 \text{ tons}} = \mathbf{\$142/\text{ton}}$$

Therefore, the IGCC plant becomes attractive when the price of coal is above \$142 per ton.

6-27E The power output and thermal efficiency of a solar pond power plant are given. The rate of solar energy collection is to be determined.

Assumptions The plant operates steadily.

Analysis The rate of solar energy collection or the rate of heat supply to the power plant is determined from the thermal efficiency relation to be

$$\dot{Q}_H = \frac{\dot{W}_{\text{net, out}}}{\eta_{\text{th}}} = \frac{350 \text{ kW}}{0.04} \left(\frac{1 \text{ Btu}}{1.055 \text{ kJ}} \right) \left(\frac{3600 \text{ s}}{1 \text{ h}} \right) = \mathbf{2.986 \times 10^7 \text{ Btu/h}}$$

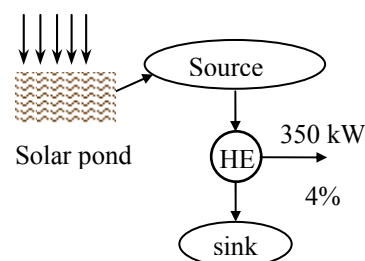

6-28 A coal-burning power plant produces 300 MW of power. The amount of coal consumed during a one-day period and the rate of air flowing through the furnace are to be determined.

Assumptions **1** The power plant operates steadily. **2** The kinetic and potential energy changes are zero.

Properties The heating value of the coal is given to be 28,000 kJ/kg.

Analysis (a) The rate and the amount of heat inputs to the power plant are

$$\dot{Q}_{\text{in}} = \frac{\dot{W}_{\text{net,out}}}{\eta_{\text{th}}} = \frac{300 \text{ MW}}{0.32} = 937.5 \text{ MW}$$

$$Q_{\text{in}} = \dot{Q}_{\text{in}} \Delta t = (937.5 \text{ MJ/s})(24 \times 3600 \text{ s}) = 8.1 \times 10^7 \text{ MJ}$$

The amount and rate of coal consumed during this period are

$$m_{\text{coal}} = \frac{Q_{\text{in}}}{q_{\text{HV}}} = \frac{8.1 \times 10^7 \text{ MJ}}{28 \text{ MJ/kg}} = \mathbf{2.893 \times 10^6 \text{ kg}}$$

$$\dot{m}_{\text{coal}} = \frac{m_{\text{coal}}}{\Delta t} = \frac{2.893 \times 10^6 \text{ kg}}{24 \times 3600 \text{ s}} = 33.48 \text{ kg/s}$$

(b) Noting that the air-fuel ratio is 12, the rate of air flowing through the furnace is

$$\dot{m}_{\text{air}} = (\text{AF})\dot{m}_{\text{coal}} = (12 \text{ kg air/kg fuel})(33.48 \text{ kg/s}) = \mathbf{401.8 \text{ kg/s}}$$

Refrigerators and Heat Pumps

6-29C The difference between the two devices is one of purpose. The purpose of a refrigerator is to remove heat from a cold medium whereas the purpose of a heat pump is to supply heat to a warm medium.

6-30C The difference between the two devices is one of purpose. The purpose of a refrigerator is to remove heat from a refrigerated space whereas the purpose of an air-conditioner is remove heat from a living space.

6-31C No. Because the refrigerator consumes work to accomplish this task.

6-32C No. Because the heat pump consumes work to accomplish this task.

6-33C The coefficient of performance of a refrigerator represents the amount of heat removed from the refrigerated space for each unit of work supplied. It can be greater than unity.

6-34C The coefficient of performance of a heat pump represents the amount of heat supplied to the heated space for each unit of work supplied. It can be greater than unity.

6-35C No. The heat pump captures energy from a cold medium and carries it to a warm medium. It does not create it.

6-36C No. The refrigerator captures energy from a cold medium and carries it to a warm medium. It does not create it.

6-37C No device can transfer heat from a cold medium to a warm medium without requiring a heat or work input from the surroundings.

6-38C The violation of one statement leads to the violation of the other one, as shown in Sec. 6-4, and thus we conclude that the two statements are equivalent.

6-39E The COP and the power input of a residential heat pump are given. The rate of heating effect is to be determined.

Assumptions The heat pump operates steadily.

Analysis Applying the definition of the heat pump coefficient of performance to this heat pump gives

$$\dot{Q}_H = \text{COP}_{\text{HP}} \dot{W}_{\text{net,in}} = (2.4)(5 \text{ hp}) \left(\frac{2544.5 \text{ Btu/h}}{1 \text{ hp}} \right) = \mathbf{30,530 \text{ Btu/h}}$$

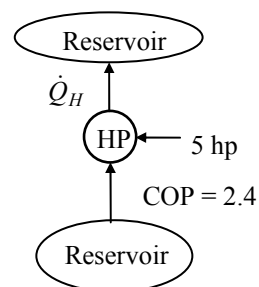

6-40 The cooling effect and the rate of heat rejection of an air conditioner are given. The COP is to be determined.

Assumptions The air conditioner operates steadily.

Analysis Applying the first law to the air conditioner gives

$$\dot{W}_{\text{net,in}} = \dot{Q}_H - \dot{Q}_L = 2.5 - 2 = 0.5 \text{ kW}$$

Applying the definition of the coefficient of performance,

$$\text{COP}_R = \frac{\dot{Q}_L}{\dot{W}_{\text{net,in}}} = \frac{2.0 \text{ kW}}{0.5 \text{ kW}} = \mathbf{4}$$

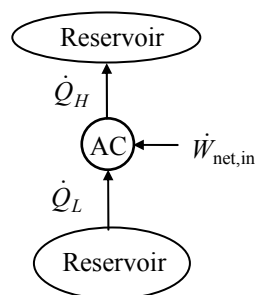

6-41 The power input and the COP of a refrigerator are given. The cooling effect of the refrigerator is to be determined.

Assumptions The refrigerator operates steadily.

Analysis Rearranging the definition of the refrigerator coefficient of performance and applying the result to this refrigerator gives

$$\dot{Q}_L = \text{COP}_R \dot{W}_{\text{net,in}} = (1.4)(3 \text{ kW}) = \mathbf{4.2 \text{ kW}}$$

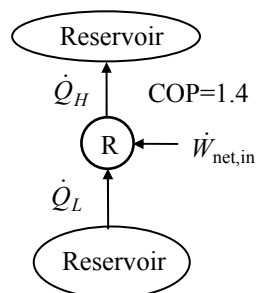

6-42 A refrigerator is used to keep a food department at a specified temperature. The heat gain to the food department and the heat rejection in the condenser are given. The power input and the COP are to be determined.

Assumptions The refrigerator operates steadily.

Analysis The power input is determined from

$$\begin{aligned}\dot{W}_{\text{in}} &= \dot{Q}_H - \dot{Q}_L \\ &= 4800 - 3300 = 1500 \text{ kJ/h} \\ &= (1500 \text{ kJ/h}) \left(\frac{1 \text{ kW}}{3600 \text{ kJ/h}} \right) = \mathbf{0.417 \text{ kW}}\end{aligned}$$

The COP is

$$\text{COP} = \frac{\dot{Q}_L}{\dot{W}_{\text{in}}} = \frac{3300 \text{ kJ/h}}{1500 \text{ kJ/h}} = \mathbf{2.2}$$

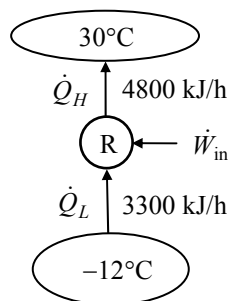

6-43 The COP and the refrigeration rate of a refrigerator are given. The power consumption and the rate of heat rejection are to be determined.

Assumptions The refrigerator operates steadily.

Analysis (a) Using the definition of the coefficient of performance, the power input to the refrigerator is determined to be

$$\dot{W}_{\text{net,in}} = \frac{\dot{Q}_L}{\text{COP}_R} = \frac{60 \text{ kJ/min}}{1.2} = 50 \text{ kJ/min} = \mathbf{0.83 \text{ kW}}$$

(b) The heat transfer rate to the kitchen air is determined from the energy balance,

$$\dot{Q}_H = \dot{Q}_L + \dot{W}_{\text{net,in}} = 60 + 50 = \mathbf{110 \text{ kJ/min}}$$

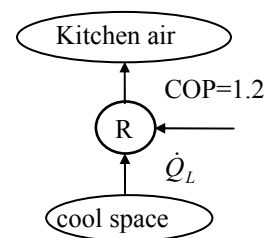

6-44E The heat absorption, the heat rejection, and the power input of a commercial heat pump are given. The COP of the heat pump is to be determined.

Assumptions The heat pump operates steadily.

Analysis Applying the definition of the heat pump coefficient of performance to this heat pump gives

$$\text{COP}_{\text{HP}} = \frac{\dot{Q}_H}{\dot{W}_{\text{net,in}}} = \frac{15,090 \text{ Btu/h}}{2 \text{ hp}} \left(\frac{1 \text{ hp}}{2544.5 \text{ Btu/h}} \right) = \mathbf{2.97}$$

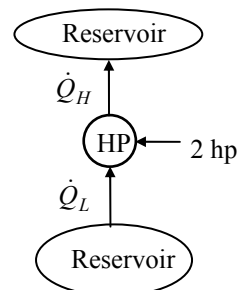

6-45 The cooling effect and the COP of a refrigerator are given. The power input to the refrigerator is to be determined.

Assumptions The refrigerator operates steadily.

Analysis Rearranging the definition of the refrigerator coefficient of performance and applying the result to this refrigerator gives

$$\dot{W}_{\text{net,in}} = \frac{\dot{Q}_L}{\text{COP}_R} = \frac{25,000 \text{ kJ/h}}{1.60} \left(\frac{1 \text{ h}}{3600 \text{ s}} \right) = \mathbf{4.34 \text{ kW}}$$

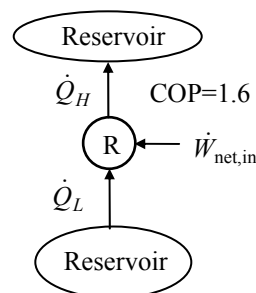

6-46 The COP and the power consumption of a refrigerator are given. The time it will take to cool 5 watermelons is to be determined.

Assumptions 1 The refrigerator operates steadily. **2** The heat gain of the refrigerator through its walls, door, etc. is negligible. **3** The watermelons are the only items in the refrigerator to be cooled.

Properties The specific heat of watermelons is given to be $c = 4.2 \text{ kJ/kg}\cdot^\circ\text{C}$.

Analysis The total amount of heat that needs to be removed from the watermelons is

$$Q_L = (mc\Delta T)_{\text{watermelons}} = 5 \times (10 \text{ kg})(4.2 \text{ kJ/kg}\cdot^\circ\text{C})(20 - 8)^\circ\text{C} = 2520 \text{ kJ}$$

The rate at which this refrigerator removes heat is

$$\dot{Q}_L = (\text{COP}_R)(\dot{W}_{\text{net,in}}) = (2.5)(0.45 \text{ kW}) = 1.125 \text{ kW}$$

That is, this refrigerator can remove 1.125 kJ of heat per second. Thus the time required to remove 2520 kJ of heat is

$$\Delta t = \frac{Q_L}{\dot{Q}_L} = \frac{2520 \text{ kJ}}{1.125 \text{ kJ/s}} = \mathbf{2240 \text{ s} = 37.3 \text{ min}}$$

This answer is optimistic since the refrigerated space will gain some heat during this process from the surrounding air, which will increase the work load. Thus, in reality, it will take longer to cool the watermelons.

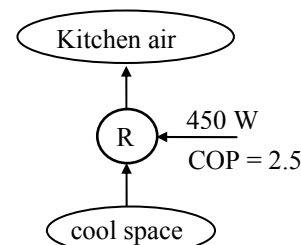

6-47  An air conditioner with a known COP cools a house to desired temperature in 15 min. The power consumption of the air conditioner is to be determined.

Assumptions **1** The air conditioner operates steadily. **2** The house is well-sealed so that no air leaks in or out during cooling. **3** Air is an ideal gas with constant specific heats at room temperature.

Properties The constant volume specific heat of air is given to be $c_v = 0.72 \text{ kJ/kg} \cdot ^\circ\text{C}$.

Analysis Since the house is well-sealed (constant volume), the total amount of heat that needs to be removed from the house is

$$Q_L = (mc_v \Delta T)_{\text{House}} = (800 \text{ kg})(0.72 \text{ kJ/kg} \cdot ^\circ\text{C})(35 - 20)^\circ\text{C} = 8640 \text{ kJ}$$

This heat is removed in 30 minutes. Thus the average rate of heat removal from the house is

$$\dot{Q}_L = \frac{Q_L}{\Delta t} = \frac{8640 \text{ kJ}}{30 \times 60 \text{ s}} = 4.8 \text{ kW}$$

Using the definition of the coefficient of performance, the power input to the air-conditioner is determined to be

$$\dot{W}_{\text{net,in}} = \frac{\dot{Q}_L}{\text{COP}_R} = \frac{4.8 \text{ kW}}{2.8} = \mathbf{1.71 \text{ kW}}$$

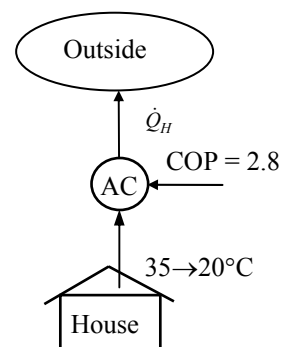



6-48 Problem 6-47 is reconsidered. The rate of power drawn by the air conditioner required to cool the house as a function for air conditioner EER ratings in the range 5 to 15 is to be investigated. Representative costs of air conditioning units in the EER rating range are to be included.

Analysis The problem is solved using EES, and the results are tabulated and plotted below.

"Since it is well sealed, we treat the house as a closed system (constant volume) to determine the rate of heat transfer required to cool the house. Apply the first law, closed system on a rate basis to the house."

"Input Data"

T_1=35 [C]
 T_2=20 [C]
 c_v = 0.72 [kJ/kg-C]
 m_house=800 [kg]
 DELTAtime=30 [min]
 "EER=5"
 COP=EER/3.412

"Assuming no work done on the house and no heat energy added to the house in the time period with no change in KE and PE, the first law applied to the house is:"

E_dot_in - E_dot_out = DELTAE_dot
 E_dot_in = 0
 E_dot_out = Q_dot_L
 DELTAE_dot = m_house*DELTAu_house/DELTAtime
 DELTAu_house = c_v*(T_2-T_1)

"Using the definition of the coefficient of performance of the A/C:"

W_dot_in = Q_dot_L/COP "kJ/min"*convert('kJ/min','kW') "kW"
 Q_dot_H= W_dot_in*convert('KW','kJ/min') + Q_dot_L "kJ/min"

| EER | \dot{W}_{in} [kW] |
|-----|---------------------|
| 5 | 3.276 |
| 6 | 2.73 |
| 7 | 2.34 |
| 8 | 2.047 |
| 9 | 1.82 |
| 10 | 1.638 |
| 11 | 1.489 |
| 12 | 1.365 |
| 13 | 1.26 |
| 14 | 1.17 |
| 15 | 1.092 |

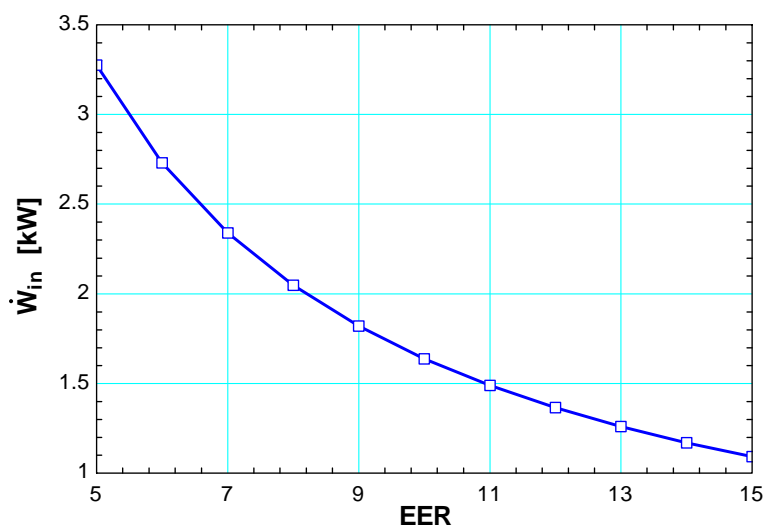

6-49 A refrigerator is used to cool bananas to a specified temperature. The power input is given. The rate of cooling and the COP are to be determined.

Assumptions The refrigerator operates steadily.

Properties The specific heat of banana is $3.35 \text{ kJ/kg}\cdot^\circ\text{C}$.

Analysis The rate of cooling is determined from

$$\dot{Q}_L = \dot{m}c_p(T_1 - T_2) = (215/60 \text{ kg/min})(3.35 \text{ kJ/kg}\cdot^\circ\text{C})(24 - 13)^\circ\text{C} = \mathbf{132 \text{ kJ/min}}$$

The COP is

$$\text{COP} = \frac{\dot{Q}_L}{\dot{W}_{\text{in}}} = \frac{(132/60) \text{ kW}}{1.4 \text{ kW}} = \mathbf{1.57}$$

6-50 A refrigerator is used to cool water to a specified temperature. The power input is given. The flow rate of water and the COP of the refrigerator are to be determined.

Assumptions The refrigerator operates steadily.

Properties The specific heat of water is $4.18 \text{ kJ/kg}\cdot^\circ\text{C}$ and its density is 1 kg/L .

Analysis The rate of cooling is determined from

$$\dot{Q}_L = \dot{Q}_H - \dot{W}_{\text{in}} = (570/60) \text{ kW} - 2.65 \text{ kW} = 6.85 \text{ kW}$$

The mass flow rate of water is

$$\dot{Q}_L = \dot{m}c_p(T_1 - T_2) \longrightarrow \dot{m} = \frac{\dot{Q}_L}{c_p(T_1 - T_2)} = \frac{6.85 \text{ kW}}{(4.18 \text{ kJ/kg}\cdot^\circ\text{C})(23 - 5)^\circ\text{C}} = 0.09104 \text{ kg/s}$$

The volume flow rate is

$$\dot{V} = \frac{\dot{m}}{\rho} = \frac{0.09104 \text{ kg/s}}{1 \text{ kg/L}} \left(\frac{60 \text{ s}}{1 \text{ min}} \right) = \mathbf{5.46 \text{ L/min}}$$

The COP is

$$\text{COP} = \frac{\dot{Q}_L}{\dot{W}_{\text{in}}} = \frac{6.85 \text{ kW}}{2.65 \text{ kW}} = \mathbf{2.58}$$

6-51 The rate of heat loss, the rate of internal heat gain, and the COP of a heat pump are given. The power input to the heat pump is to be determined.

Assumptions The heat pump operates steadily.

Analysis The heating load of this heat pump system is the difference between the heat lost to the outdoors and the heat generated in the house from the people, lights, and appliances,

$$\dot{Q}_H = 60,000 - 4,000 = 56,000 \text{ kJ/h}$$

Using the definition of COP, the power input to the heat pump is determined to be

$$\dot{W}_{\text{net,in}} = \frac{\dot{Q}_H}{\text{COP}_{\text{HP}}} = \frac{56,000 \text{ kJ/h}}{2.5} \left(\frac{1 \text{ kW}}{3600 \text{ kJ/h}} \right) = \mathbf{6.22 \text{ kW}}$$

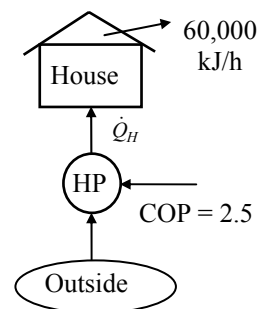

6-52E The COP and the refrigeration rate of an ice machine are given. The power consumption is to be determined.

Assumptions The ice machine operates steadily.

Analysis The cooling load of this ice machine is

$$\dot{Q}_L = \dot{m}q_L = (28 \text{ lbm/h})(169 \text{ Btu/lbm}) = 4732 \text{ Btu/h}$$

Using the definition of the coefficient of performance, the power input to the ice machine system is determined to be

$$\dot{W}_{\text{net,in}} = \frac{\dot{Q}_L}{\text{COP}_R} = \frac{4732 \text{ Btu/h}}{2.4} \left(\frac{1 \text{ hp}}{2545 \text{ Btu/h}} \right) = \mathbf{0.775 \text{ hp}}$$

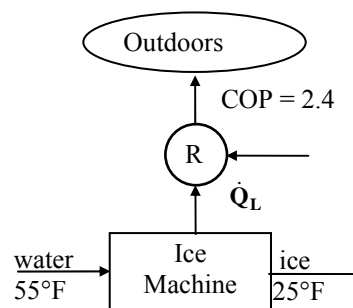

6-53E An office that is being cooled adequately by a 12,000 Btu/h window air-conditioner is converted to a computer room. The number of additional air-conditioners that need to be installed is to be determined.

Assumptions 1 The computers are operated by 7 adult men. **2** The computers consume 40 percent of their rated power at any given time.

Properties The average rate of heat generation from a person seated in a room/office is 100 W (given).

Analysis The amount of heat dissipated by the computers is equal to the amount of electrical energy they consume. Therefore,

$$\dot{Q}_{\text{computers}} = (\text{Rated power}) \times (\text{Usage factor}) = (8.4 \text{ kW})(0.4) = 3.36 \text{ kW}$$

$$\dot{Q}_{\text{people}} = (\text{No. of people}) \times \dot{Q}_{\text{person}} = 7 \times (100 \text{ W}) = 700 \text{ W}$$

$$\dot{Q}_{\text{total}} = \dot{Q}_{\text{computers}} + \dot{Q}_{\text{people}} = 3360 + 700 = 4060 \text{ W} = 13,853 \text{ Btu/h}$$

since 1 W = 3.412 Btu/h. Then noting that each available air conditioner provides 7000 Btu/h cooling, the number of air-conditioners needed becomes

$$\begin{aligned} \text{No. of air conditioners} &= \frac{\text{Cooling load}}{\text{Cooling capacity of A/C}} = \frac{13,853 \text{ Btu/h}}{7000 \text{ Btu/h}} \\ &= 1.98 \approx \mathbf{2 \text{ Air conditioners}} \end{aligned}$$

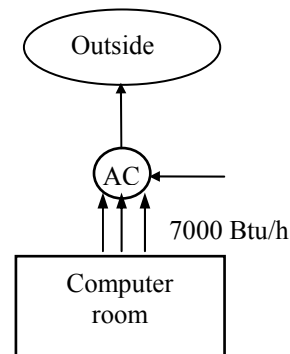

6-54 A decision is to be made between a cheaper but inefficient air-conditioner and an expensive but efficient air-conditioner for a building. The better buy is to be determined.

Assumptions The two air conditioners are comparable in all aspects other than the initial cost and the efficiency.

Analysis The unit that will cost less during its lifetime is a better buy. The total cost of a system during its lifetime (the initial, operation, maintenance, etc.) can be determined by performing a life cycle cost analysis. A simpler alternative is to determine the simple payback period. The energy and cost savings of the more efficient air conditioner in this case is

$$\begin{aligned}\text{Energy savings} &= (\text{Annual energy usage of A}) - (\text{Annual energy usage of B}) \\ &= (\text{Annual cooling load})(1/\text{COP}_A - 1/\text{COP}_B) \\ &= (120,000 \text{ kWh/year})(1/3.2 - 1/5.0) \\ &= 13,500 \text{ kWh/year}\end{aligned}$$

$$\begin{aligned}\text{Cost savings} &= (\text{Energy savings})(\text{Unit cost of energy}) \\ &= (13,500 \text{ kWh/year})(\$0.10/\text{kWh}) = \mathbf{\$1350/\text{year}}\end{aligned}$$

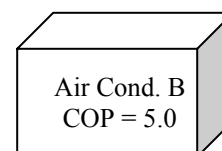
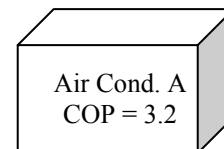

The installation cost difference between the two air-conditioners is

$$\text{Cost difference} = \text{Cost of B} - \text{cost of A} = 7000 - 5500 = \$1500$$

Therefore, the more efficient air-conditioner B will pay for the \$1500 cost differential in this case in about 1 year.

Discussion A cost conscious consumer will have no difficulty in deciding that the more expensive but more efficient air-conditioner B is clearly the better buy in this case since air conditioners last at least 15 years. But the decision would not be so easy if the unit cost of electricity at that location was much less than \$0.10/kWh, or if the annual air-conditioning load of the house was much less than 120,000 kWh.

6-55 A house is heated by resistance heaters, and the amount of electricity consumed during a winter month is given. The amount of money that would be saved if this house were heated by a heat pump with a known COP is to be determined.

Assumptions The heat pump operates steadily.

Analysis The amount of heat the resistance heaters supply to the house is equal to the amount of electricity they consume. Therefore, to achieve the same heating effect, the house must be supplied with 1200 kWh of energy. A heat pump that supplied this much heat will consume electrical power in the amount of

$$\dot{W}_{\text{net,in}} = \frac{\dot{Q}_H}{\text{COP}_{\text{HP}}} = \frac{1200 \text{ kWh}}{2.4} = 500 \text{ kWh}$$

which represent a savings of $1200 - 500 = 700$ kWh. Thus the homeowner would have saved

$$(700 \text{ kWh})(0.085 \text{ \$/kWh}) = \mathbf{\$59.50}$$

6-56 Refrigerant-134a flows through the condenser of a residential heat pump unit. For a given compressor power consumption the COP of the heat pump and the rate of heat absorbed from the outside air are to be determined.

Assumptions 1 The heat pump operates steadily. **2** The kinetic and potential energy changes are zero.

Properties The enthalpies of R-134a at the condenser inlet and exit are

$$\left. \begin{array}{l} P_1 = 800 \text{ kPa} \\ T_1 = 35^\circ\text{C} \end{array} \right\} h_1 = 271.22 \text{ kJ/kg}$$

$$\left. \begin{array}{l} P_2 = 800 \text{ kPa} \\ x_2 = 0 \end{array} \right\} h_2 = 95.47 \text{ kJ/kg}$$

Analysis (a) An energy balance on the condenser gives the heat rejected in the condenser

$$\dot{Q}_H = \dot{m}(h_1 - h_2) = (0.018 \text{ kg/s})(271.22 - 95.47) \text{ kJ/kg} = 3.164 \text{ kW}$$

The COP of the heat pump is

$$\text{COP} = \frac{\dot{Q}_H}{\dot{W}_{\text{in}}} = \frac{3.164 \text{ kW}}{1.2 \text{ kW}} = \mathbf{2.64}$$

(b) The rate of heat absorbed from the outside air

$$\dot{Q}_L = \dot{Q}_H - \dot{W}_{\text{in}} = 3.164 - 1.2 = \mathbf{1.96 \text{ kW}}$$

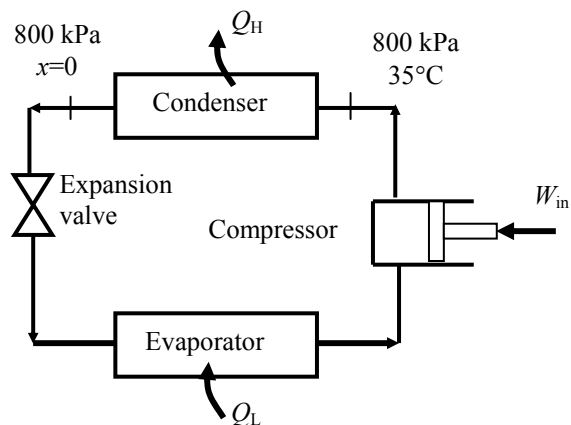

6-57 A commercial refrigerator with R-134a as the working fluid is considered. The evaporator inlet and exit states are specified. The mass flow rate of the refrigerant and the rate of heat rejected are to be determined.

Assumptions 1 The refrigerator operates steadily. **2** The kinetic and potential energy changes are zero.

Properties The properties of R-134a at the evaporator inlet and exit states are (Tables A-11 through A-13)

$$\left. \begin{array}{l} P_1 = 100 \text{ kPa} \\ x_1 = 0.2 \end{array} \right\} h_1 = 60.71 \text{ kJ/kg}$$

$$\left. \begin{array}{l} P_2 = 100 \text{ kPa} \\ T_2 = -26^\circ\text{C} \end{array} \right\} h_2 = 234.74 \text{ kJ/kg}$$

Analysis (a) The refrigeration load is

$$\dot{Q}_L = (\text{COP})\dot{W}_{\text{in}} = (1.2)(0.600 \text{ kW}) = 0.72 \text{ kW}$$

The mass flow rate of the refrigerant is determined from

$$\dot{m}_R = \frac{\dot{Q}_L}{h_2 - h_1} = \frac{0.72 \text{ kW}}{(234.74 - 60.71) \text{ kJ/kg}} = \mathbf{0.00414 \text{ kg/s}}$$

(b) The rate of heat rejected from the refrigerator is

$$\dot{Q}_H = \dot{Q}_L + \dot{W}_{\text{in}} = 0.72 + 0.60 = \mathbf{1.32 \text{ kW}}$$

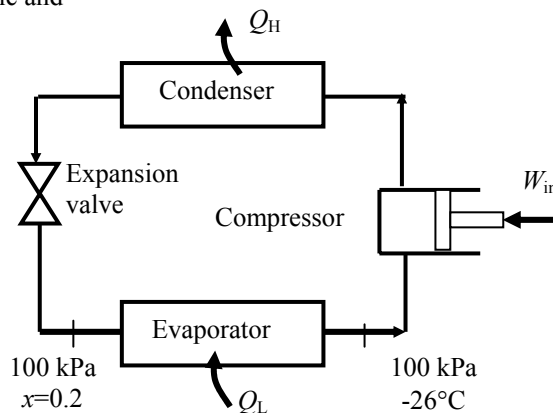

Perpetual-Motion Machines

6-58C This device creates energy, and thus it is a PMM1.

6-59C This device creates energy, and thus it is a PMM1.

Reversible and Irreversible Processes

6-60C Adiabatic stirring processes are irreversible because the energy stored within the system can not be spontaneously released in a manner to cause the mass of the system to turn the **paddle wheel** in the opposite direction to do work on the surroundings.

6-61C The chemical reactions of combustion processes of a natural gas and air mixture will generate carbon dioxide, water, and other compounds and will release heat energy to a lower temperature surroundings. It is unlikely that the surroundings will return this energy to the reacting system and the products of combustion react spontaneously to reproduce the natural gas and air mixture.

6-62C No. Because it involves heat transfer through a finite temperature difference.

6-63C This process is irreversible. As the block slides down the plane, two things happen, (a) the potential energy of the block decreases, and (b) the block and plane warm up because of the friction between them. The potential energy that has been released can be stored in some form in the surroundings (e.g., perhaps in a spring). When we restore the system to its original condition, we must (a) restore the potential energy by lifting the block back to its original elevation, and (b) cool the block and plane back to their original temperatures.

The potential energy may be restored by returning the energy that was stored during the original process as the block decreased its elevation and released potential energy. The portion of the surroundings in which this energy had been stored would then return to its original condition as the elevation of the block is restored to its original condition.

In order to cool the block and plane to their original temperatures, we have to remove heat from the block and plane. When this heat is transferred to the surroundings, something in the surroundings has to change its state (e.g., perhaps we warm up some water in the surroundings). This change in the surroundings is permanent and cannot be undone. Hence, the original process is irreversible.

6-64C Because reversible processes can be approached in reality, and they form the limiting cases. Work producing devices that operate on reversible processes deliver the most work, and work consuming devices that operate on reversible processes consume the least work.

6-65C When the compression process is non-quasi equilibrium, the molecules before the piston face cannot escape fast enough, forming a high pressure region in front of the piston. It takes more work to move the piston against this high pressure region.

6-66C When an expansion process is non-quasiequilibrium, the molecules before the piston face cannot follow the piston fast enough, forming a low pressure region behind the piston. The lower pressure that pushes the piston produces less work.

6-67C The irreversibilities that occur within the system boundaries are **internal** irreversibilities; those which occur outside the system boundaries are **external** irreversibilities.

6-68C A reversible expansion or compression process cannot involve unrestrained expansion or sudden compression, and thus it is quasi-equilibrium. A quasi-equilibrium expansion or compression process, on the other hand, may involve external irreversibilities (such as heat transfer through a finite temperature difference), and thus is not necessarily reversible.

The Carnot Cycle and Carnot's Principle

6-69C The four processes that make up the Carnot cycle are isothermal expansion, reversible adiabatic expansion, isothermal compression, and reversible adiabatic compression.

6-70C They are (1) the thermal efficiency of an irreversible heat engine is lower than the efficiency of a reversible heat engine operating between the same two reservoirs, and (2) the thermal efficiency of all the reversible heat engines operating between the same two reservoirs are equal.

6-71C False. The second Carnot principle states that no heat engine cycle can have a higher thermal efficiency than the Carnot cycle operating between the same temperature limits.

6-72C Yes. The second Carnot principle states that all reversible heat engine cycles operating between the same temperature limits have the same thermal efficiency.

6-73C (a) No, (b) No. They would violate the Carnot principle.

Carnot Heat Engines

6-74C No.

6-75C The one that has a source temperature of 600°C. This is true because the higher the temperature at which heat is supplied to the working fluid of a heat engine, the higher the thermal efficiency.

6-76E The source and sink temperatures of a heat engine are given. The maximum work per unit heat input to the engine is to be determined.

Assumptions The heat engine operates steadily.

Analysis The maximum work per unit of heat that the engine can remove from the source is the Carnot efficiency, which is determined from

$$\frac{W_{\text{net}}}{Q_H} = \eta_{\text{th,max}} = 1 - \frac{T_L}{T_H} = 1 - \frac{510 \text{ R}}{1260 \text{ R}} = \mathbf{0.595}$$

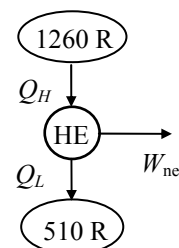

6-77 Two pairs of thermal energy reservoirs are to be compared from a work-production perspective.

Assumptions The heat engine operates steadily.

Analysis For the maximum production of work, a heat engine operating between the energy reservoirs would have to be completely reversible. Then, for the first pair of reservoirs

$$\eta_{\text{th,max}} = 1 - \frac{T_L}{T_H} = 1 - \frac{325 \text{ K}}{675 \text{ K}} = \mathbf{0.519}$$

For the second pair of reservoirs,

$$\eta_{\text{th,max}} = 1 - \frac{T_L}{T_H} = 1 - \frac{275 \text{ K}}{625 \text{ K}} = \mathbf{0.560}$$

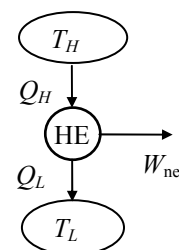

The second pair is then capable of producing more work for each unit of heat extracted from the hot reservoir.

6-78  The source and sink temperatures of a heat engine and the rate of heat supply are given. The maximum possible power output of this engine is to be determined.

Assumptions The heat engine operates steadily.

Analysis The highest thermal efficiency a heat engine operating between two specified temperature limits can have is the Carnot efficiency, which is determined from

$$\eta_{\text{th,max}} = \eta_{\text{th,C}} = 1 - \frac{T_L}{T_H} = 1 - \frac{298 \text{ K}}{(477 + 273) \text{ K}} = 0.600 \text{ or } 60.0\%$$

Then the maximum power output of this heat engine is determined from the definition of thermal efficiency to be

$$\dot{W}_{\text{net,out}} = \eta_{\text{th}} \dot{Q}_H = (0.600)(65,000 \text{ kJ/min}) = 39,000 \text{ kJ/min} = \mathbf{653 \text{ kW}}$$

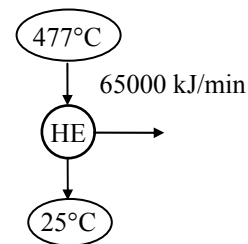



6-79 Problem 6-78 is reconsidered. The effects of the temperatures of the heat source and the heat sink on the power produced and the cycle thermal efficiency as the source temperature varies from 300°C to 1000°C and the sink temperature varies from 0°C to 50°C are to be studied. The power produced and the cycle efficiency against the source temperature for sink temperatures of 0°C, 25°C, and 50°C are to be plotted.

Analysis The problem is solved using EES, and the results are tabulated and plotted below.

$$T_H = 477 \text{ [C]}$$

$$T_L = 25 \text{ [C]}$$

$$Q_{\text{dot}_H} = 65000 \text{ [kJ/min]}$$

"First Law applied to the heat engine"

$$Q_{\text{dot}_H} - Q_{\text{dot}_L} - W_{\text{dot}_net} = 0$$

$$W_{\text{dot}_net_KW} = W_{\text{dot}_net} \cdot \text{convert}(\text{kJ/min}, \text{kW})$$

"Cycle Thermal Efficiency - Temperatures must be absolute"

$$\eta_{th} = 1 - (T_L + 273) / (T_H + 273)$$

"Definition of cycle efficiency"

$$\eta_{th} = W_{\text{dot}_net} / Q_{\text{dot}_H}$$

| T_H [C] | W_{netKW} [kW] | η_{th} |
|--------------|---------------------|-------------|
| 300 | 567.2 | 0.5236 |
| 400 | 643.9 | 0.5944 |
| 500 | 700.7 | 0.6468 |
| 600 | 744.6 | 0.6873 |
| 700 | 779.4 | 0.7194 |
| 800 | 807.7 | 0.7456 |
| 900 | 831.2 | 0.7673 |
| 1000 | 851 | 0.7855 |

Values for $T_L = 0^\circ\text{C}$

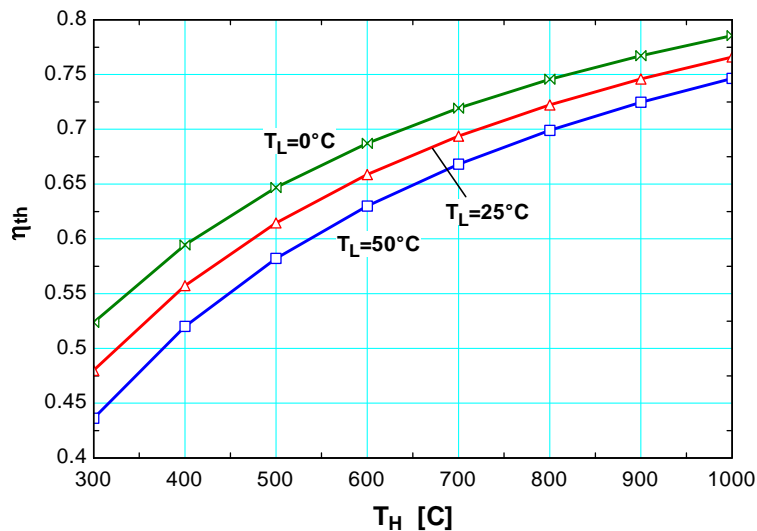
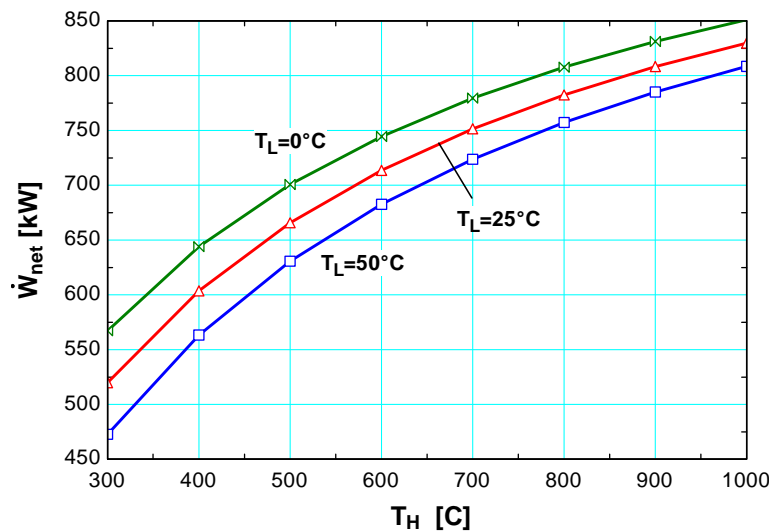

6-80E The sink temperature of a Carnot heat engine, the rate of heat rejection, and the thermal efficiency are given. The power output of the engine and the source temperature are to be determined.

Assumptions The Carnot heat engine operates steadily.

Analysis (a) The rate of heat input to this heat engine is determined from the definition of thermal efficiency,

$$\eta_{\text{th}} = 1 - \frac{\dot{Q}_L}{\dot{Q}_H} \longrightarrow 0.75 = 1 - \frac{800 \text{ Btu/min}}{\dot{Q}_H} \longrightarrow \dot{Q}_H = 3200 \text{ Btu/min}$$

Then the power output of this heat engine can be determined from

$$\dot{W}_{\text{net,out}} = \eta_{\text{th}} \dot{Q}_H = (0.75)(3200 \text{ Btu/min}) = 2400 \text{ Btu/min} = \mathbf{56.6 \text{ hp}}$$

(b) For reversible cyclic devices we have

$$\left(\frac{\dot{Q}_H}{\dot{Q}_L} \right)_{\text{rev}} = \left(\frac{T_H}{T_L} \right)$$

Thus the temperature of the source T_H must be

$$T_H = \left(\frac{\dot{Q}_H}{\dot{Q}_L} \right)_{\text{rev}} T_L = \left(\frac{3200 \text{ Btu/min}}{800 \text{ Btu/min}} \right) (520 \text{ R}) = \mathbf{2080 \text{ R}}$$

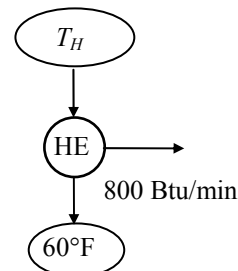

6-81E The claim of an inventor about the operation of a heat engine is to be evaluated.

Assumptions The heat engine operates steadily.

Analysis If this engine were completely reversible, the thermal efficiency would be

$$\eta_{\text{th,max}} = 1 - \frac{T_L}{T_H} = 1 - \frac{550 \text{ R}}{1000 \text{ R}} = 0.45$$

When the first law is applied to the engine above,

$$\dot{Q}_H = \dot{W}_{\text{net}} + \dot{Q}_L = (5 \text{ hp}) \left(\frac{2544.5 \text{ Btu/h}}{1 \text{ hp}} \right) + 15,000 \text{ Btu/h} = 27,720 \text{ Btu/h}$$

The actual thermal efficiency of the proposed heat engine is then

$$\eta_{\text{th}} = \frac{\dot{W}_{\text{net}}}{\dot{Q}_H} = \frac{5 \text{ hp}}{27,720 \text{ Btu/h}} \left(\frac{2544.5 \text{ Btu/h}}{1 \text{ hp}} \right) = 0.459$$

Since the thermal efficiency of the proposed heat engine is greater than that of a completely reversible heat engine which uses the same isothermal energy reservoirs, **the inventor's claim is invalid.**

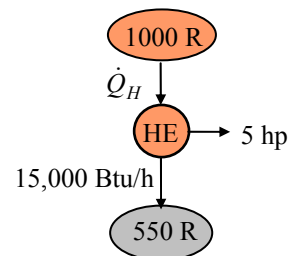

6-82 The work output and thermal efficiency of a Carnot heat engine are given. The heat supplied to the heat engine, the heat rejected and the temperature of heat sink are to be determined.

Assumptions 1 The heat engine operates steadily. 2 Heat losses from the working fluid at the pipes and other components are negligible.

Analysis Applying the definition of the thermal efficiency and an energy balance to the heat engine, the unknown values are determined as follows:

$$Q_H = \frac{W_{\text{net}}}{\eta_{\text{th}}} = \frac{500 \text{ kJ}}{0.4} = \mathbf{1250 \text{ kJ}}$$

$$Q_L = Q_H - W_{\text{net}} = 1250 - 500 = \mathbf{750 \text{ kJ}}$$

$$\eta_{\text{th,max}} = 1 - \frac{T_L}{T_H} \longrightarrow 0.40 = 1 - \frac{T_L}{(1200 + 273) \text{ K}} \longrightarrow T_L = 883.8 \text{ K} = \mathbf{611^\circ\text{C}}$$

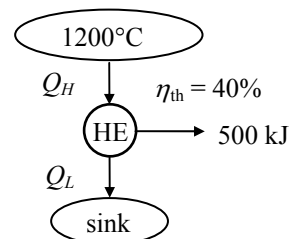

6-83 The work output and heat rejection of a Carnot heat engine are given. The heat supplied to the heat engine and the source temperature are to be determined.

Assumptions 1 The heat engine operates steadily. 2 Heat losses from the working fluid at the pipes and other components are negligible.

Analysis Applying the definition of the thermal efficiency and an energy balance to the heat engine, the unknown values are determined as follows:

$$Q_H = Q_L + W_{\text{net}} = 150 + 900 = \mathbf{1050 \text{ kJ}}$$

$$\eta_{\text{th}} = \frac{W_{\text{net}}}{Q_H} = \frac{900 \text{ kJ}}{1050 \text{ kJ}} = 0.857$$

$$\eta_{\text{th,max}} = 1 - \frac{T_L}{T_H} \longrightarrow 0.857 = 1 - \frac{(27 + 273) \text{ K}}{T_H} \longrightarrow T_H = 2100 \text{ K} = \mathbf{1827^\circ\text{C}}$$

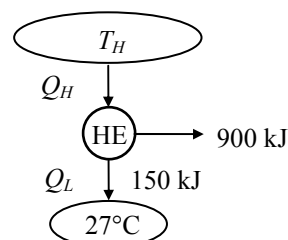

6-84 The thermal efficiency and waste heat rejection of a Carnot heat engine are given. The power output and the temperature of the source are to be determined.

Assumptions 1 The heat engine operates steadily. 2 Heat losses from the working fluid at the pipes and other components are negligible.

Analysis Applying the definition of the thermal efficiency and an energy balance to the heat engine, the power output and the source temperature are determined as follows:

$$\eta_{\text{th}} = 1 - \frac{\dot{Q}_L}{\dot{Q}_H} \longrightarrow 0.75 = 1 - \frac{14 \text{ kW}}{\dot{Q}_H} \longrightarrow \dot{Q}_H = 56 \text{ kW}$$

$$\dot{W}_{\text{net}} = \eta_{\text{th}} \dot{Q}_H = (0.75)(56 \text{ kW}) = \mathbf{42 \text{ kW}}$$

$$\eta_{\text{th}} = 1 - \frac{T_L}{T_H} \longrightarrow 0.75 = 1 - \frac{(15 + 273) \text{ K}}{T_H} \longrightarrow T_H = 1152 \text{ K} = \mathbf{879^\circ\text{C}}$$

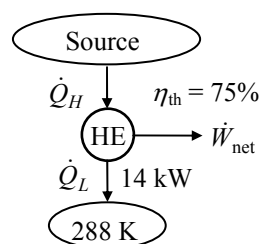

6-85 A geothermal power plant uses geothermal liquid water at 150°C at a specified rate as the heat source. The actual and maximum possible thermal efficiencies and the rate of heat rejected from this power plant are to be determined.

Assumptions 1 The power plant operates steadily. **2** The kinetic and potential energy changes are zero. **3** Steam properties are used for geothermal water.

Properties Using saturated liquid properties, (Table A-4)

$$\left. \begin{array}{l} T_{\text{source},1} = 150^\circ\text{C} \\ x_{\text{source}} = 0 \end{array} \right\} h_{\text{geo},1} = 632.18 \text{ kJ/kg}$$

$$\left. \begin{array}{l} T_{\text{source},2} = 90^\circ\text{C} \\ x_{\text{source}} = 0 \end{array} \right\} h_{\text{source}} = 377.04 \text{ kJ/kg}$$

$$\left. \begin{array}{l} T_{\text{sink}} = 25^\circ\text{C} \\ x_{\text{sink}} = 0 \end{array} \right\} h_{\text{sink}} = 104.83 \text{ kJ/kg}$$

Analysis (a) The rate of heat input to the plant is

$$\dot{Q}_{\text{in}} = \dot{m}_{\text{geo}}(h_{\text{geo},1} - h_{\text{geo},2}) = (210 \text{ kg/s})(632.18 - 377.04) \text{ kJ/kg} = 53,580 \text{ kW}$$

The actual thermal efficiency is

$$\eta_{\text{th}} = \frac{\dot{W}_{\text{net,out}}}{\dot{Q}_{\text{in}}} = \frac{8000 \text{ kW}}{53,580 \text{ kW}} = \mathbf{0.1493 = 14.9\%}$$

(b) The maximum thermal efficiency is the thermal efficiency of a reversible heat engine operating between the source and sink temperatures

$$\eta_{\text{th,max}} = 1 - \frac{T_L}{T_H} = 1 - \frac{(25 + 273) \text{ K}}{(150 + 273) \text{ K}} = \mathbf{0.2955 = 29.6\%}$$

(c) Finally, the rate of heat rejection is

$$\dot{Q}_{\text{out}} = \dot{Q}_{\text{in}} - \dot{W}_{\text{net,out}} = 53,580 - 8000 = \mathbf{45,580 \text{ kW}}$$

6-86 The claim that the efficiency of a completely reversible heat engine can be doubled by doubling the temperature of the energy source is to be evaluated.

Assumptions The heat engine operates steadily.

Analysis The upper limit for the thermal efficiency of any heat engine occurs when a completely reversible engine operates between the same energy reservoirs. The thermal efficiency of this completely reversible engine is given by

$$\eta_{\text{th,rev}} = 1 - \frac{T_L}{T_H} = \frac{T_H - T_L}{T_H}$$

If we were to double the absolute temperature of the high temperature energy reservoir, the new thermal efficiency would be

$$\eta_{\text{th,rev}} = 1 - \frac{T_L}{2T_H} = \frac{2T_H - T_L}{2T_H} < 2 \frac{T_H - T_L}{T_H}$$

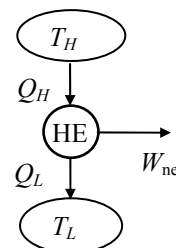

The thermal efficiency is then **not doubled** as the temperature of the high temperature reservoir is doubled.

Carnot Refrigerators and Heat Pumps

6-87C By increasing T_L or by decreasing T_H .

6-88C The difference between the temperature limits is typically much higher for a refrigerator than it is for an air conditioner. The smaller the difference between the temperature limits a refrigerator operates on, the higher is the COP. Therefore, an air-conditioner should have a higher COP.

6-89C The deep freezer should have a lower COP since it operates at a much lower temperature, and in a given environment, the COP decreases with decreasing refrigeration temperature.

6-90C No. At best (when everything is reversible), the increase in the work produced will be equal to the work consumed by the refrigerator. In reality, the work consumed by the refrigerator will always be greater than the additional work produced, resulting in a decrease in the thermal efficiency of the power plant.

6-91C No. At best (when everything is reversible), the increase in the work produced will be equal to the work consumed by the refrigerator. In reality, the work consumed by the refrigerator will always be greater than the additional work produced, resulting in a decrease in the thermal efficiency of the power plant.

6-92C Bad idea. At best (when everything is reversible), the increase in the work produced will be equal to the work consumed by the heat pump. In reality, the work consumed by the heat pump will always be greater than the additional work produced, resulting in a decrease in the thermal efficiency of the power plant.

6-93 The minimum work per unit of heat transfer from the low-temperature source for a refrigerator is to be determined.

Assumptions The refrigerator operates steadily.

Analysis Application of the first law gives

$$\frac{W_{\text{net,in}}}{Q_L} = \frac{Q_H - Q_L}{Q_L} = \frac{Q_H}{Q_L} - 1$$

For the minimum work input, this refrigerator would be completely reversible and the thermodynamic definition of temperature would reduce the preceding expression to

$$\frac{W_{\text{net,in}}}{Q_L} = \frac{T_H}{T_L} - 1 = \frac{303 \text{ K}}{273 \text{ K}} - 1 = \mathbf{0.110}$$

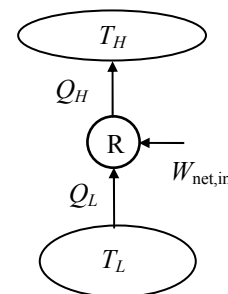

6-94 The validity of a claim by an inventor related to the operation of a heat pump is to be evaluated.

Assumptions The heat pump operates steadily.

Analysis Applying the definition of the heat pump coefficient of performance,

$$COP_{HP} = \frac{\dot{Q}_H}{\dot{W}_{net,in}} = \frac{200 \text{ kW}}{75 \text{ kW}} = 2.67$$

The maximum COP of a heat pump operating between the same temperature limits is

$$COP_{HP,max} = \frac{1}{1 - T_L / T_H} = \frac{1}{1 - (273 \text{ K}) / (293 \text{ K})} = 14.7$$

Since the actual COP is less than the maximum COP, the claim is **valid**.

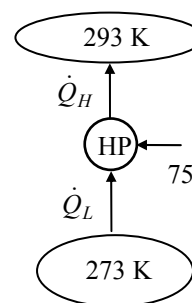

6-95 The power input and the COP of a Carnot heat pump are given. The temperature of the low-temperature reservoir and the heating load are to be determined.

Assumptions The heat pump operates steadily.

Analysis The temperature of the low-temperature reservoir is

$$COP_{HP,max} = \frac{T_H}{T_H - T_L} \longrightarrow 8.7 = \frac{299 \text{ K}}{(299 - T_L) \text{ K}} \longrightarrow T_L = \mathbf{264.6 \text{ K}}$$

The heating load is

$$COP_{HP,max} = \frac{\dot{Q}_H}{\dot{W}_{in}} \longrightarrow 8.7 = \frac{\dot{Q}_H}{4.25 \text{ kW}} \longrightarrow \dot{Q}_H = \mathbf{37.0 \text{ kW}}$$

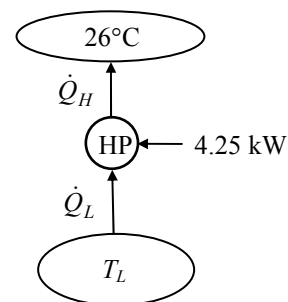

6-96 The refrigerated space and the environment temperatures for a refrigerator and the rate of heat removal from the refrigerated space are given. The minimum power input required is to be determined.

Assumptions The refrigerator operates steadily.

Analysis The power input to a refrigerator will be a minimum when the refrigerator operates in a reversible manner. The coefficient of performance of a reversible refrigerator depends on the temperature limits in the cycle only, and is determined from

$$COP_{R,rev} = \frac{1}{(T_H / T_L) - 1} = \frac{1}{(25 + 273 \text{ K}) / (-8 + 273 \text{ K}) - 1} = 8.03$$

The power input to this refrigerator is determined from the definition of the coefficient of performance of a refrigerator,

$$\dot{W}_{net,in,min} = \frac{\dot{Q}_L}{COP_{R,max}} = \frac{300 \text{ kJ/min}}{8.03} = 37.36 \text{ kJ/min} = \mathbf{0.623 \text{ kW}}$$

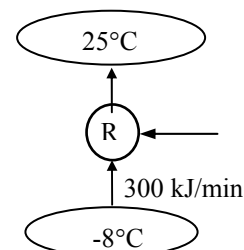

6-97 An inventor claims to have developed a refrigerator. The inventor reports temperature and COP measurements. The claim is to be evaluated.

Analysis The highest coefficient of performance a refrigerator can have when removing heat from a cool medium at -12°C to a warmer medium at 25°C is

$$\text{COP}_{\text{R,max}} = \text{COP}_{\text{R,rev}} = \frac{1}{(T_H/T_L)-1} = \frac{1}{(25 + 273 \text{ K})/(-12 + 273 \text{ K})-1} = 7.1$$

The COP claimed by the inventor is 6.5, which is below this maximum value, thus the claim is **reasonable**. However, it is not probable.

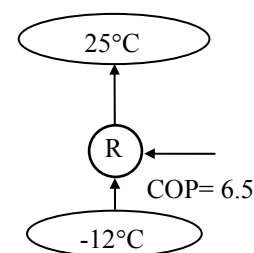

6-98E An air-conditioning system maintains a house at a specified temperature. The rate of heat gain of the house and the rate of internal heat generation are given. The maximum power input required is to be determined.

Assumptions The air-conditioner operates steadily.

Analysis The power input to an air-conditioning system will be a minimum when the air-conditioner operates in a reversible manner. The coefficient of performance of a reversible air-conditioner (or refrigerator) depends on the temperature limits in the cycle only, and is determined from

$$\text{COP}_{\text{R,rev}} = \frac{1}{(T_H/T_L)-1} = \frac{1}{(100 + 460 \text{ R})/(70 + 460 \text{ R})-1} = 17.67$$

The cooling load of this air-conditioning system is the sum of the heat gain from the outside and the heat generated within the house,

$$\dot{Q}_L = 800 + 100 = 900 \text{ Btu/min}$$

The power input to this refrigerator is determined from the definition of the coefficient of performance of a refrigerator,

$$\dot{W}_{\text{net,in,min}} = \frac{\dot{Q}_L}{\text{COP}_{\text{R,max}}} = \frac{900 \text{ Btu/min}}{17.67} = 50.93 \text{ Btu/min} = \mathbf{1.20 \text{ hp}}$$

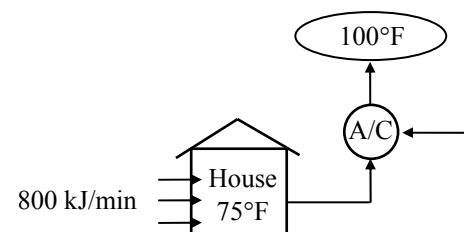

6-99 A heat pump maintains a house at a specified temperature. The rate of heat loss of the house and the power consumption of the heat pump are given. It is to be determined if this heat pump can do the job.

Assumptions The heat pump operates steadily.

Analysis The power input to a heat pump will be a minimum when the heat pump operates in a reversible manner. The coefficient of performance of a reversible heat pump depends on the temperature limits in the cycle only, and is determined from

$$\text{COP}_{\text{HP,rev}} = \frac{1}{1 - (T_L / T_H)} = \frac{1}{1 - (2 + 273 \text{ K}) / (22 + 273 \text{ K})} = 14.75$$

The required power input to this reversible heat pump is determined from the definition of the coefficient of performance to be

$$\dot{W}_{\text{net,in,min}} = \frac{\dot{Q}_H}{\text{COP}_{\text{HP}}} = \frac{110,000 \text{ kJ/h}}{14.75} \left(\frac{1 \text{ h}}{3600 \text{ s}} \right) = \mathbf{2.07 \text{ kW}}$$

This heat pump is **powerful enough** since $5 \text{ kW} > 2.07 \text{ kW}$.

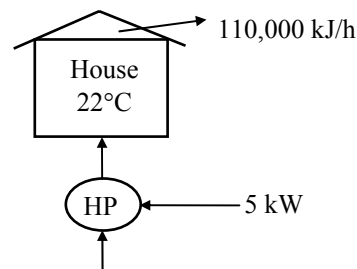

6-100E The power required by a reversible refrigerator with specified reservoir temperatures is to be determined.

Assumptions The refrigerator operates steadily.

Analysis The COP of this reversible refrigerator is

$$\text{COP}_{\text{R,max}} = \frac{T_L}{T_H - T_L} = \frac{450 \text{ R}}{540 \text{ R} - 450 \text{ R}} = 5$$

Using this result in the coefficient of performance expression yields

$$\dot{W}_{\text{net,in}} = \frac{\dot{Q}_L}{\text{COP}_{\text{R,max}}} = \frac{15,000 \text{ Btu/h}}{5} \left(\frac{1 \text{ kW}}{3412.14 \text{ Btu/h}} \right) = \mathbf{0.879 \text{ kW}}$$

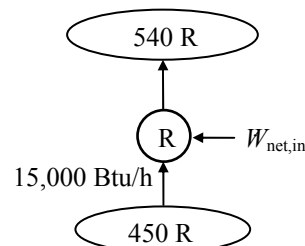

6-101 The power input and heat rejection of a reversed Carnot cycle are given. The cooling load and the source temperature are to be determined.

Assumptions The refrigerator operates steadily.

Analysis Applying the definition of the refrigerator coefficient of performance,

$$\dot{Q}_L = \dot{Q}_H - \dot{W}_{\text{net,in}} = 2000 - 200 = \mathbf{1800 \text{ kW}}$$

Applying the definition of the heat pump coefficient of performance,

$$\text{COP}_{\text{R}} = \frac{\dot{Q}_L}{\dot{W}_{\text{net,in}}} = \frac{1800 \text{ kW}}{200 \text{ kW}} = 9$$

The temperature of the heat source is determined from

$$\text{COP}_{\text{R,max}} = \frac{T_L}{T_H - T_L} \longrightarrow 9 = \frac{T_L}{300 - T_L} \longrightarrow T_L = 270 \text{ K} = \mathbf{-3^\circ\text{C}}$$

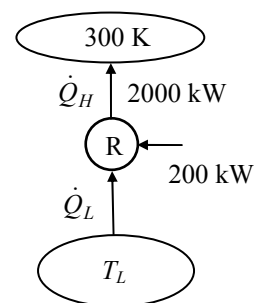

6-102 The power input and the cooling load of an air conditioner are given. The rate of heat rejected in the condenser, the COP, and the rate of cooling for a reversible operation are to be determined.

Assumptions The air conditioner operates steadily.

Analysis (a) The rate of heat rejected is

$$\begin{aligned}\dot{Q}_H &= \dot{Q}_L + \dot{W}_{in} \\ &= (18,000 \text{ Btu/h}) \left(\frac{1.055 \text{ kJ}}{1 \text{ Btu}} \right) + (3.4 \text{ kW}) \left(\frac{3600 \text{ kJ/h}}{1 \text{ kW}} \right) \\ &= \mathbf{31,230 \text{ kJ/h}}\end{aligned}$$

(b) The COP is

$$COP = \frac{\dot{Q}_L}{\dot{W}_{in}} = \frac{(18,000 \text{ Btu/h}) \left(\frac{1 \text{ kW}}{3412 \text{ Btu/h}} \right)}{3.4 \text{ kW}} = \mathbf{1.552}$$

(c) The rate of cooling if the air conditioner operated as a Carnot refrigerator for the same power input is

$$\begin{aligned}COP_{rev} &= \frac{T_L}{T_H - T_L} = \frac{295 \text{ K}}{(33 - 22) \text{ K}} = 26.82 \\ \dot{Q}_{L,max} &= COP_{rev} \dot{W}_{in,min} = (26.82) \left[(3.4 \text{ kW}) \left(\frac{3412 \text{ Btu/h}}{1 \text{ kW}} \right) \right] = \mathbf{311,130 \text{ Btu/h}}\end{aligned}$$

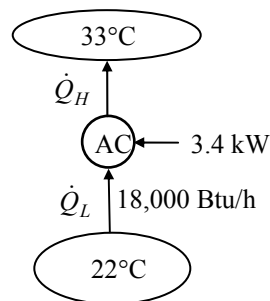

6-103 The rate of heat removal and the source and sink temperatures are given for a Carnot refrigerator. The COP of the refrigerator and the power input are to be determined.

Assumptions The refrigerator operates steadily.

Analysis The COP of the Carnot refrigerator is determined from

$$COP_{R,max} = \frac{T_L}{T_H - T_L} = \frac{288 \text{ K}}{(36 - 15) \text{ K}} = \mathbf{13.71}$$

The power input is

$$COP_{R,max} = \frac{\dot{Q}_L}{\dot{W}_{in}} \longrightarrow 13.71 = \frac{16,000 \text{ kJ/h}}{\dot{W}_{in}} \longrightarrow \dot{W}_{in} = 1167 \text{ kJ/h} = \mathbf{0.324 \text{ kW}}$$

The rate of heat rejected is

$$\dot{Q}_H = \dot{Q}_L + \dot{W}_{net,in} = 16,000 \text{ kJ/h} + 1167 \text{ kJ/h} = \mathbf{17,167 \text{ kJ/h}}$$

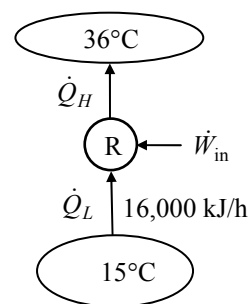

6-104 A heat pump maintains a house at a specified temperature in winter. The maximum COPs of the heat pump for different outdoor temperatures are to be determined.

Analysis The coefficient of performance of a heat pump will be a maximum when the heat pump operates in a reversible manner. The coefficient of performance of a reversible heat pump depends on the temperature limits in the cycle only, and is determined for all three cases above to be

$$\text{COP}_{\text{HP,rev}} = \frac{1}{1 - (T_L / T_H)} = \frac{1}{1 - (10 + 273\text{K}) / (20 + 273\text{K})} = \mathbf{29.3}$$

$$\text{COP}_{\text{HP,rev}} = \frac{1}{1 - (T_L / T_H)} = \frac{1}{1 - (-5 + 273\text{K}) / (20 + 273\text{K})} = \mathbf{11.7}$$

$$\text{COP}_{\text{HP,rev}} = \frac{1}{1 - (T_L / T_H)} = \frac{1}{1 - (-30 + 273\text{K}) / (20 + 273\text{K})} = \mathbf{5.86}$$

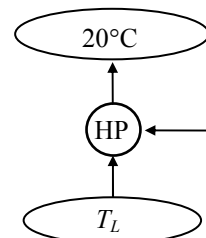

6-105E A heat pump maintains a house at a specified temperature. The rate of heat loss of the house is given. The minimum power inputs required for different source temperatures are to be determined.

Assumptions The heat pump operates steadily.

Analysis (a) The power input to a heat pump will be a minimum when the heat pump operates in a reversible manner. If the outdoor air at 25°F is used as the heat source, the COP of the heat pump and the required power input are determined to be

$$\begin{aligned} \text{COP}_{\text{HP,max}} = \text{COP}_{\text{HP,rev}} &= \frac{1}{1 - (T_L / T_H)} \\ &= \frac{1}{1 - (25 + 460 \text{ R}) / (78 + 460 \text{ R})} = \mathbf{10.15} \end{aligned}$$

and

$$\dot{W}_{\text{net,in,min}} = \frac{\dot{Q}_H}{\text{COP}_{\text{HP,max}}} = \frac{55,000 \text{ Btu/h}}{10.15} \left(\frac{1 \text{ hp}}{2545 \text{ Btu/h}} \right) = \mathbf{2.13 \text{ hp}}$$

(b) If the well-water at 50°F is used as the heat source, the COP of the heat pump and the required power input are determined to be

$$\text{COP}_{\text{HP,max}} = \text{COP}_{\text{HP,rev}} = \frac{1}{1 - (T_L / T_H)} = \frac{1}{1 - (50 + 460 \text{ R}) / (78 + 460 \text{ R})} = \mathbf{19.2}$$

and

$$\dot{W}_{\text{net,in,min}} = \frac{\dot{Q}_H}{\text{COP}_{\text{HP,max}}} = \frac{55,000 \text{ Btu/h}}{19.2} \left(\frac{1 \text{ hp}}{2545 \text{ Btu/h}} \right) = \mathbf{1.13 \text{ hp}}$$

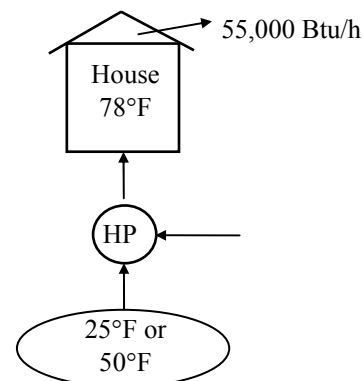

6-106 A Carnot heat pump consumes 6.6-kW of power when operating, and maintains a house at a specified temperature. The average rate of heat loss of the house in a particular day is given. The actual running time of the heat pump that day, the heating cost, and the cost if resistance heating is used instead are to be determined.

Analysis (a) The coefficient of performance of this Carnot heat pump depends on the temperature limits in the cycle only, and is determined from

$$\text{COP}_{\text{HP,rev}} = \frac{1}{1 - (T_L / T_H)} = \frac{1}{1 - (2 + 273 \text{ K}) / (25 + 273 \text{ K})} = 12.96$$

The amount of heat the house lost that day is

$$Q_H = \dot{Q}_H (1 \text{ day}) = (55,000 \text{ kJ/h})(24 \text{ h}) = 1,320,000 \text{ kJ}$$

Then the required work input to this Carnot heat pump is determined from the definition of the coefficient of performance to be

$$W_{\text{net,in}} = \frac{Q_H}{\text{COP}_{\text{HP}}} = \frac{1,320,000 \text{ kJ}}{12.96} = 101,880 \text{ kJ}$$

Thus the length of time the heat pump ran that day is

$$\Delta t = \frac{W_{\text{net,in}}}{\dot{W}_{\text{net,in}}} = \frac{101,880 \text{ kJ}}{6.6 \text{ kJ/s}} = 15,440 \text{ s} = \mathbf{4.29 \text{ h}}$$

(b) The total heating cost that day is

$$\text{Cost} = W \times \text{price} = (\dot{W}_{\text{net,in}} \times \Delta t)(\text{price}) = (6.6 \text{ kW})(4.29 \text{ h})(0.085 \text{ \$/kWh}) = \mathbf{\$2.41}$$

(c) If resistance heating were used, the entire heating load for that day would have to be met by electrical energy. Therefore, the heating system would consume 1,320,000 kJ of electricity that would cost

$$\text{New Cost} = Q_H \times \text{price} = (1,320,000 \text{ kJ}) \left(\frac{1 \text{ kWh}}{3600 \text{ kJ}} \right) (0.085 \text{ \$/kWh}) = \mathbf{\$31.2}$$

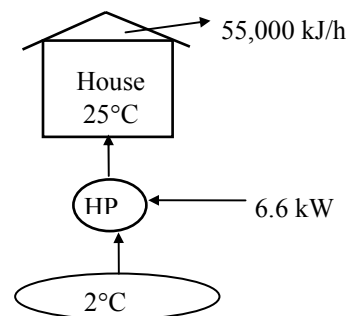

6-107 A Carnot heat engine is used to drive a Carnot refrigerator. The maximum rate of heat removal from the refrigerated space and the total rate of heat rejection to the ambient air are to be determined.

Assumptions The heat engine and the refrigerator operate steadily.

Analysis (a) The highest thermal efficiency a heat engine operating between two specified temperature limits can have is the Carnot efficiency, which is determined from

$$\eta_{\text{th,max}} = \eta_{\text{th,C}} = 1 - \frac{T_L}{T_H} = 1 - \frac{300 \text{ K}}{1173 \text{ K}} = 0.744$$

Then the maximum power output of this heat engine is determined from the definition of thermal efficiency to be

$$\dot{W}_{\text{net,out}} = \eta_{\text{th}} \dot{Q}_H = (0.744)(800 \text{ kJ/min}) = 595.2 \text{ kJ/min}$$

which is also the power input to the refrigerator, $\dot{W}_{\text{net,in}}$.

The rate of heat removal from the refrigerated space will be a maximum if a Carnot refrigerator is used. The COP of the Carnot refrigerator is

$$\text{COP}_{\text{R,rev}} = \frac{1}{(T_H/T_L) - 1} = \frac{1}{(27 + 273 \text{ K})/(-5 + 273 \text{ K}) - 1} = 8.37$$

Then the rate of heat removal from the refrigerated space becomes

$$\dot{Q}_{L,R} = (\text{COP}_{\text{R,rev}})(\dot{W}_{\text{net,in}}) = (8.37)(595.2 \text{ kJ/min}) = \mathbf{4982 \text{ kJ/min}}$$

(b) The total rate of heat rejection to the ambient air is the sum of the heat rejected by the heat engine ($\dot{Q}_{L,\text{HE}}$) and the heat discarded by the refrigerator ($\dot{Q}_{H,R}$),

$$\dot{Q}_{L,\text{HE}} = \dot{Q}_{H,\text{HE}} - \dot{W}_{\text{net,out}} = 800 - 595.2 = 204.8 \text{ kJ/min}$$

$$\dot{Q}_{H,R} = \dot{Q}_{L,R} + \dot{W}_{\text{net,in}} = 4982 + 595.2 = 5577.2 \text{ kJ/min}$$

and

$$\dot{Q}_{\text{ambient}} = \dot{Q}_{L,\text{HE}} + \dot{Q}_{H,R} = 204.8 + 5577.2 = \mathbf{5782 \text{ kJ/min}}$$

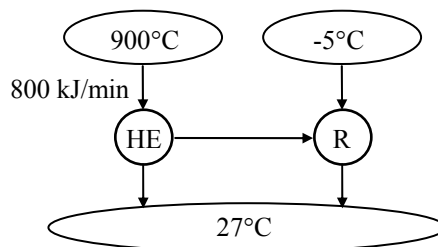

6-108E A Carnot heat engine is used to drive a Carnot refrigerator. The maximum rate of heat removal from the refrigerated space and the total rate of heat rejection to the ambient air are to be determined.

Assumptions The heat engine and the refrigerator operate steadily.

Analysis (a) The highest thermal efficiency a heat engine operating between two specified temperature limits can have is the Carnot efficiency, which is determined from

$$\eta_{\text{th,max}} = \eta_{\text{th,C}} = 1 - \frac{T_L}{T_H} = 1 - \frac{540 \text{ R}}{2160 \text{ R}} = 0.75$$

Then the maximum power output of this heat engine is determined from the definition of thermal efficiency to be

$$\dot{W}_{\text{net,out}} = \eta_{\text{th}} \dot{Q}_H = (0.75)(700 \text{ Btu/min}) = 525 \text{ Btu/min}$$

which is also the power input to the refrigerator, $\dot{W}_{\text{net,in}}$.

The rate of heat removal from the refrigerated space will be a maximum if a Carnot refrigerator is used. The COP of the Carnot refrigerator is

$$COP_{R,\text{rev}} = \frac{1}{(T_H/T_L) - 1} = \frac{1}{(80 + 460 \text{ R})/(20 + 460 \text{ R}) - 1} = 8.0$$

Then the rate of heat removal from the refrigerated space becomes

$$\dot{Q}_{L,R} = (COP_{R,\text{rev}})(\dot{W}_{\text{net,in}}) = (8.0)(525 \text{ Btu/min}) = \mathbf{4200 \text{ Btu/min}}$$

(b) The total rate of heat rejection to the ambient air is the sum of the heat rejected by the heat engine ($\dot{Q}_{L,\text{HE}}$) and the heat discarded by the refrigerator ($\dot{Q}_{H,R}$),

$$\dot{Q}_{L,\text{HE}} = \dot{Q}_{H,\text{HE}} - \dot{W}_{\text{net,out}} = 700 - 525 = 175 \text{ Btu/min}$$

$$\dot{Q}_{H,R} = \dot{Q}_{L,R} + \dot{W}_{\text{net,in}} = 4200 + 525 = 4725 \text{ Btu/min}$$

and

$$\dot{Q}_{\text{ambient}} = \dot{Q}_{L,\text{HE}} + \dot{Q}_{H,R} = 175 + 4725 = \mathbf{4900 \text{ Btu/min}}$$

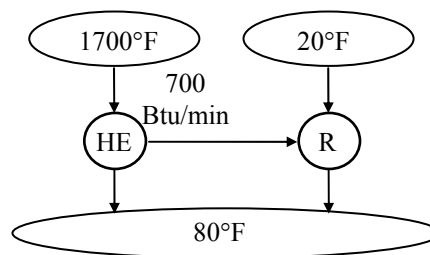

6-109 A heat pump that consumes 4-kW of power when operating maintains a house at a specified temperature. The house is losing heat in proportion to the temperature difference between the indoors and the outdoors. The lowest outdoor temperature for which this heat pump can do the job is to be determined.

Assumptions The heat pump operates steadily.

Analysis Denoting the outdoor temperature by T_L , the heating load of this house can be expressed as

$$\dot{Q}_H = (3800 \text{ kJ/h} \cdot \text{K})(297 - T_L) = (1.056 \text{ kW/K})(297 - T_L)\text{K}$$

The coefficient of performance of a Carnot heat pump depends on the temperature limits in the cycle only, and can be expressed as

$$\text{COP}_{\text{HP}} = \frac{1}{1 - (T_L / T_H)} = \frac{1}{1 - T_L / (297 \text{ K})}$$

or, as

$$\text{COP}_{\text{HP}} = \frac{\dot{Q}_H}{\dot{W}_{\text{net,in}}} = \frac{(1.056 \text{ kW/K})(297 - T_L)\text{K}}{4 \text{ kW}}$$

Equating the two relations above and solving for T_L , we obtain

$$T_L = 263.5 \text{ K} = \mathbf{-9.5^\circ\text{C}}$$

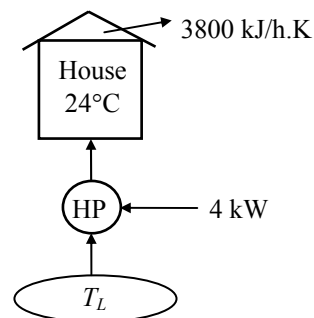

6-110 An air-conditioner with R-134a as the working fluid is considered. The compressor inlet and exit states are specified. The actual and maximum COPs and the minimum volume flow rate of the refrigerant at the compressor inlet are to be determined.

Assumptions 1 The air-conditioner operates steadily. **2** The kinetic and potential energy changes are zero.

Properties The properties of R-134a at the compressor inlet and exit states are (Tables A-11 through A-13)

$$\left. \begin{aligned} P_1 &= 400 \text{ kPa} \\ x_1 &= 1 \end{aligned} \right\} \begin{aligned} h_1 &= 255.55 \text{ kJ/kg} \\ v_1 &= 0.05120 \text{ m}^3/\text{kg} \end{aligned}$$

$$\left. \begin{aligned} P_2 &= 1.2 \text{ MPa} \\ T_2 &= 70^\circ\text{C} \end{aligned} \right\} h_2 = 300.61 \text{ kJ/kg}$$

Analysis (a) The mass flow rate of the refrigerant and the power consumption of the compressor are

$$\dot{m}_R = \frac{\dot{V}_1}{v_1} = \frac{100 \text{ L/min} \left(\frac{1 \text{ m}^3}{1000 \text{ L}} \right) \left(\frac{1 \text{ min}}{60 \text{ s}} \right)}{0.05120 \text{ m}^3/\text{kg}} = 0.03255 \text{ kg/s}$$

$$\dot{W}_{\text{in}} = \dot{m}_R (h_2 - h_1) = (0.03255 \text{ kg/s})(300.61 - 255.55) \text{ kJ/kg} = 1.467 \text{ kW}$$

The heat gains to the room must be rejected by the air-conditioner. That is,

$$\dot{Q}_L = \dot{Q}_{\text{heat}} + \dot{Q}_{\text{equipment}} = (250 \text{ kJ/min}) \left(\frac{1 \text{ min}}{60 \text{ s}} \right) + 0.9 \text{ kW} = 5.067 \text{ kW}$$

Then, the actual COP becomes

$$\text{COP} = \frac{\dot{Q}_L}{\dot{W}_{\text{in}}} = \frac{5.067 \text{ kW}}{1.467 \text{ kW}} = \mathbf{3.45}$$

(b) The COP of a reversible refrigerator operating between the same temperature limits is

$$\text{COP}_{\text{max}} = \frac{1}{T_H / T_L - 1} = \frac{1}{(37 + 273)/(23 + 273) - 1} = \mathbf{21.14}$$

(c) The minimum power input to the compressor for the same refrigeration load would be

$$\dot{W}_{\text{in,min}} = \frac{\dot{Q}_L}{\text{COP}_{\text{max}}} = \frac{5.067 \text{ kW}}{21.14} = 0.2396 \text{ kW}$$

The minimum mass flow rate is

$$\dot{m}_{R,\text{min}} = \frac{\dot{W}_{\text{in,min}}}{h_2 - h_1} = \frac{0.2396 \text{ kW}}{(300.61 - 255.55) \text{ kJ/kg}} = 0.005318 \text{ kg/s}$$

Finally, the minimum volume flow rate at the compressor inlet is

$$\dot{V}_{\text{min},1} = \dot{m}_{R,\text{min}} v_1 = (0.005318 \text{ kg/s})(0.05120 \text{ m}^3/\text{kg}) = 0.0002723 \text{ m}^3/\text{s} = \mathbf{16.3 \text{ L/min}}$$

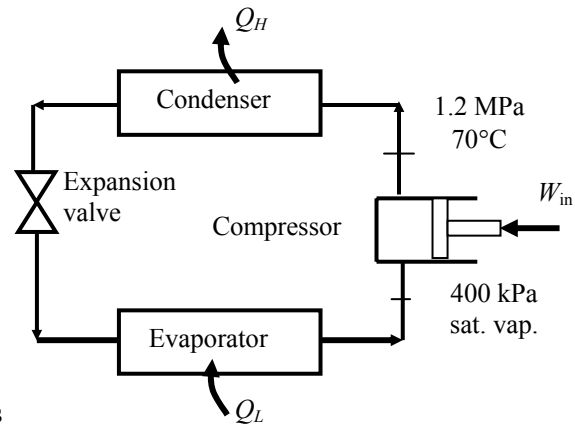

6-111 The COP of a completely reversible refrigerator as a function of the temperature of the sink is to be calculated and plotted.

Assumptions The refrigerator operates steadily.

Analysis The coefficient of performance for this completely reversible refrigerator is given by

$$\text{COP}_{R,\max} = \frac{T_L}{T_H - T_L} = \frac{250 \text{ K}}{T_H - 250 \text{ K}}$$

Using EES, we tabulate and plot the variation of COP with the sink temperature as follows:

| T_H [K] | $\text{COP}_{R,\max}$ |
|-----------|-----------------------|
| 300 | 5 |
| 320 | 3.571 |
| 340 | 2.778 |
| 360 | 2.273 |
| 380 | 1.923 |
| 400 | 1.667 |
| 420 | 1.471 |
| 440 | 1.316 |
| 460 | 1.19 |
| 480 | 1.087 |
| 500 | 1 |

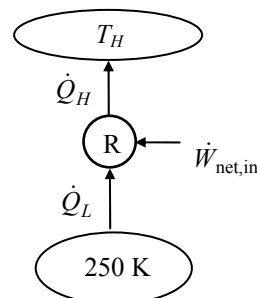
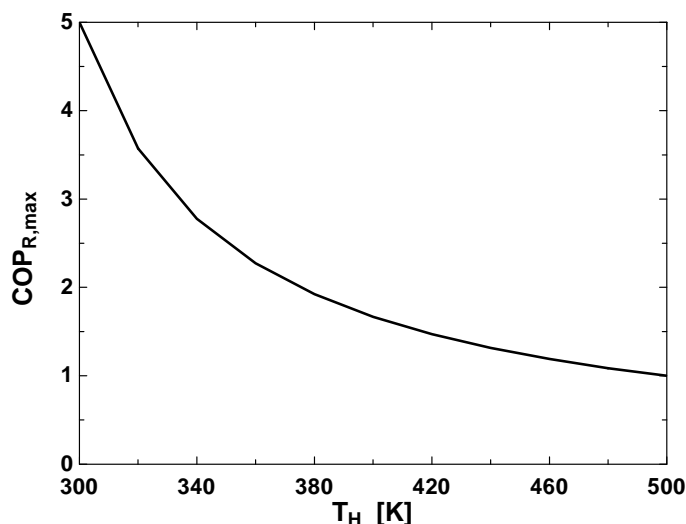

6-112 An expression for the COP of a completely reversible refrigerator in terms of the thermal-energy reservoir temperatures, T_L and T_H is to be derived.

Assumptions The refrigerator operates steadily.

Analysis Application of the first law to the completely reversible refrigerator yields

$$W_{\text{net,in}} = Q_H - Q_L$$

This result may be used to reduce the coefficient of performance,

$$\text{COP}_{R,\text{rev}} = \frac{Q_L}{W_{\text{net,in}}} = \frac{Q_L}{Q_H - Q_L} = \frac{1}{Q_H / Q_L - 1}$$

Since this refrigerator is completely reversible, the thermodynamic definition of temperature tells us that,

$$\frac{Q_H}{Q_L} = \frac{T_H}{T_L}$$

When this is substituted into the COP expression, the result is

$$\text{COP}_{R,\text{rev}} = \frac{1}{T_H / T_L - 1} = \frac{T_L}{T_H - T_L}$$

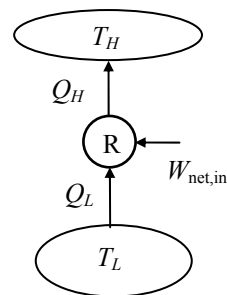

Special Topic: Household Refrigerators

6-113C The energy consumption of a household refrigerator can be reduced by practicing good conservation measures such as (1) opening the refrigerator door the fewest times possible and for the shortest duration possible, (2) cooling the hot foods to room temperature first before putting them into the refrigerator, (3) cleaning the condenser coils behind the refrigerator, (4) checking the door gasket for air leaks, (5) avoiding unnecessarily low temperature settings, (6) avoiding excessive ice build-up on the interior surfaces of the evaporator, (7) using the power-saver switch that controls the heating coils that prevent condensation on the outside surfaces in humid environments, and (8) not blocking the air flow passages to and from the condenser coils of the refrigerator.

6-114C It is important to clean the condenser coils of a household refrigerator a few times a year since the dust that collects on them serves as insulation and slows down heat transfer. Also, it is important not to block air flow through the condenser coils since heat is rejected through them by natural convection, and blocking the air flow will interfere with this heat rejection process. A refrigerator cannot work unless it can reject the waste heat.

6-115C Today's refrigerators are much more efficient than those built in the past as a result of using smaller and higher efficiency motors and compressors, better insulation materials, larger coil surface areas, and better door seals.

6-116C It is a bad idea to overdesign the refrigeration system of a supermarket so that the entire air-conditioning needs of the store can be met by refrigerated air without installing any air-conditioning system. This is because the refrigerators cool the air to a much lower temperature than needed for air conditioning, and thus their efficiency is much lower, and their operating cost is much higher.

6-117C It is a bad idea to meet the entire refrigerator/freezer requirements of a store by using a large freezer that supplies sufficient cold air at -20°C instead of installing separate refrigerators and freezers. This is because the freezers cool the air to a much lower temperature than needed for refrigeration, and thus their efficiency is much lower, and their operating cost is much higher.

6-118 A refrigerator consumes 300 W when running, and \$74 worth of electricity per year under normal use. The fraction of the time the refrigerator will run in a year is to be determined.

Assumptions The electricity consumed by the light bulb is negligible.

Analysis The total amount of electricity the refrigerator uses a year is

$$\text{Total electric energy used} = W_{e,\text{total}} = \frac{\text{Total cost of energy}}{\text{Unit cost of energy}} = \frac{\$74/\text{year}}{\$0.07/\text{kWh}} = 1057 \text{ kWh/year}$$

The number of hours the refrigerator is on per year is

$$\text{Total operating hours} = \Delta t = \frac{W_{e,\text{total}}}{\dot{W}_e} = \frac{1057 \text{ kWh/year}}{0.3 \text{ kW}} = 3524 \text{ h/year}$$

Noting that there are $365 \times 24 = 8760$ hours in a year, the fraction of the time the refrigerator is on during a year is determined to be

$$\text{Time fraction on} = \frac{\text{Total operating hours}}{\text{Total hours per year}} = \frac{3524/\text{year}}{8760 \text{ h/year}} = \mathbf{0.402}$$

Therefore, the refrigerator remained on 40.2% of the time.

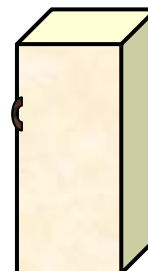

6-119 The light bulb of a refrigerator is to be replaced by a \$25 energy efficient bulb that consumes less than half the electricity. It is to be determined if the energy savings of the efficient light bulb justify its cost.

Assumptions The new light bulb remains on the same number of hours a year.

Analysis The lighting energy saved a year by the energy efficient bulb is

$$\begin{aligned} \text{Lighting energy saved} &= (\text{Lighting power saved})(\text{Operating hours}) \\ &= [(40 - 18) \text{ W}](60 \text{ h/year}) \\ &= 1320 \text{ Wh} = 1.32 \text{ kWh} \end{aligned}$$

This means 1.32 kWh less heat is supplied to the refrigerated space by the light bulb, which must be removed from the refrigerated space. This corresponds to a refrigeration savings of

$$\text{Refrigeration energy saved} = \frac{\text{Lighting energy saved}}{\text{COP}} = \frac{1.32 \text{ kWh}}{1.3} = 1.02 \text{ kWh}$$

Then the total electrical energy and money saved by the energy efficient light bulb become

$$\begin{aligned} \text{Total energy saved} &= (\text{Lighting} + \text{Refrigeration}) \text{ energy saved} = 1.32 + 1.02 = 2.34 \text{ kWh/year} \\ \text{Money saved} &= (\text{Total energy saved})(\text{Unit cost of energy}) = (2.34 \text{ kWh/year})(\$0.08/\text{kWh}) \\ &= \mathbf{\$0.19/\text{year}} \end{aligned}$$

That is, the light bulb will save only 19 cents a year in energy costs, and it will take $\$25/\$0.19 = 132$ years for it to pay for itself from the energy it saves. Therefore, it is **not justified** in this case.

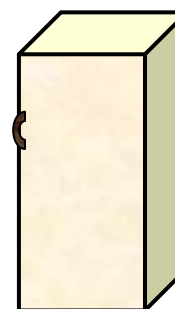

6-120 A person cooks three times a week and places the food into the refrigerator before cooling it first. The amount of money this person will save a year by cooling the hot foods to room temperature before refrigerating them is to be determined.

Assumptions **1** The heat stored in the pan itself is negligible. **2** The specific heat of the food is constant.

Properties The specific heat of food is $c = 3.90 \text{ kJ/kg} \cdot ^\circ\text{C}$ (given).

Analysis The amount of hot food refrigerated per year is

$$m_{\text{food}} = (5 \text{ kg/pan})(3 \text{ pans/week})(52 \text{ weeks/year}) = 780 \text{ kg/year}$$

The amount of energy removed from food as it is unnecessarily cooled to room temperature in the refrigerator is

$$\text{Energy removed} = Q_{\text{out}} = m_{\text{food}} c \Delta T = (780 \text{ kg/year})(3.90 \text{ kJ/kg} \cdot ^\circ\text{C})(95 - 23)^\circ\text{C} = 219,024 \text{ kJ/year}$$

$$\text{Energy saved} = E_{\text{saved}} = \frac{\text{Energy removed}}{\text{COP}} = \frac{219,024 \text{ kJ/year}}{1.5} \left(\frac{1 \text{ kWh}}{3600 \text{ kJ}} \right) = 40.56 \text{ kWh/year}$$

$$\text{Money saved} = (\text{Energy saved})(\text{Unit cost of energy}) = (40.56 \text{ kWh/year})(\$0.10/\text{kWh}) = \mathbf{\$4.06/\text{year}}$$

Therefore, cooling the food to room temperature before putting it into the refrigerator will save about four dollars a year.

6-121 The door of a refrigerator is opened 8 times a day, and half of the cool air inside is replaced by the warmer room air. The cost of the energy wasted per year as a result of opening the refrigerator door is to be determined for the cases of moist and dry air in the room.

Assumptions 1 The room is maintained at 20°C and 95 kPa at all times. **2** Air is an ideal gas with constant specific heats at room temperature. **3** The moisture is condensed at an average temperature of 4°C. **4** Half of the air volume in the refrigerator is replaced by the warmer kitchen air each time the door is opened.

Properties The gas constant of air is $R = 0.287 \text{ kPa}\cdot\text{m}^3/\text{kg}\cdot\text{K}$ (Table A-1). The specific heat of air at room temperature is $c_p = 1.005 \text{ kJ/kg}\cdot^\circ\text{C}$ (Table A-2a). The heat of vaporization of water at 4°C is $h_{fg} = 2492 \text{ kJ/kg}$ (Table A-4).

Analysis The volume of the refrigerated air replaced each time the refrigerator is opened is 0.3 m^3 (half of the 0.6 m^3 air volume in the refrigerator). Then the total volume of refrigerated air replaced by room air per year is

$$V_{\text{air, replaced}} = (0.3 \text{ m}^3)(8/\text{day})(365 \text{ days/year}) = 876 \text{ m}^3/\text{year}$$

The density of air at the refrigerated space conditions of 95 kPa and 4°C and the mass of air replaced per year are

$$\rho_o = \frac{P_o}{RT_o} = \frac{95 \text{ kPa}}{(0.287 \text{ kPa}\cdot\text{m}^3/\text{kg}\cdot\text{K})(4 + 273 \text{ K})} = 1.195 \text{ kg/m}^3$$

$$m_{\text{air}} = \rho V_{\text{air}} = (1.195 \text{ kg/m}^3)(876 \text{ m}^3/\text{year}) = 1047 \text{ kg/year}$$

The amount of moisture condensed and removed by the refrigerator is

$$\begin{aligned} m_{\text{moisture}} &= m_{\text{air}} (\text{moisture removed per kg air}) = (1047 \text{ kg air/year})(0.006 \text{ kg/kg air}) \\ &= 6.28 \text{ kg/year} \end{aligned}$$



The sensible, latent, and total heat gains of the refrigerated space become

$$\begin{aligned} Q_{\text{gain, sensible}} &= m_{\text{air}} c_p (T_{\text{room}} - T_{\text{refrig}}) \\ &= (1047 \text{ kg/year})(1.005 \text{ kJ/kg}\cdot^\circ\text{C})(20 - 4)^\circ\text{C} = 16,836 \text{ kJ/year} \end{aligned}$$

$$\begin{aligned} Q_{\text{gain, latent}} &= m_{\text{moisture}} h_{fg} \\ &= (6.28 \text{ kg/year})(2492 \text{ kJ/kg}) = 15,650 \text{ kJ/year} \end{aligned}$$

$$Q_{\text{gain, total}} = Q_{\text{gain, sensible}} + Q_{\text{gain, latent}} = 16,836 + 15,650 = 32,486 \text{ kJ/year}$$

For a COP of 1.4, the amount of electrical energy the refrigerator will consume to remove this heat from the refrigerated space and its cost are

$$\text{Electrical energy used (total)} = \frac{Q_{\text{gain, total}}}{\text{COP}} = \frac{32,486 \text{ kJ/year}}{1.4} \left(\frac{1 \text{ kWh}}{3600 \text{ kJ}} \right) = 6.45 \text{ kWh/year}$$

$$\begin{aligned} \text{Cost of energy used (total)} &= (\text{Energy used})(\text{Unit cost of energy}) \\ &= (6.45 \text{ kWh/year})(\$0.075/\text{kWh}) = \mathbf{\$0.48/\text{year}} \end{aligned}$$

If the room air is very dry and thus latent heat gain is negligible, then the amount of electrical energy the refrigerator will consume to remove the sensible heat from the refrigerated space and its cost become

$$\text{Electrical energy used (sensible)} = \frac{Q_{\text{gain, sensible}}}{\text{COP}} = \frac{16,836 \text{ kJ/year}}{1.4} \left(\frac{1 \text{ kWh}}{3600 \text{ kJ}} \right) = 3.34 \text{ kWh/year}$$

$$\begin{aligned} \text{Cost of energy used (sensible)} &= (\text{Energy used})(\text{Unit cost of energy}) \\ &= (3.34 \text{ kWh/year})(\$0.075/\text{kWh}) = \mathbf{\$0.25/\text{year}} \end{aligned}$$

Review Problems

6-122 The source and sink temperatures of a heat engine are given. The maximum work per unit heat input to the engine is to be determined.

Assumptions The heat engine operates steadily.

Analysis The maximum work per unit of heat that the engine can remove from the source is the Carnot efficiency, which is determined from

$$\frac{W_{\text{net}}}{Q_H} = \eta_{\text{th,max}} = 1 - \frac{T_L}{T_H} = 1 - \frac{290 \text{ K}}{1280 \text{ K}} = \mathbf{0.773}$$

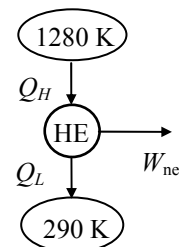

6-123 The work output and the source and sink temperatures of a Carnot heat engine are given. The heat supplied to and rejected from the heat engine are to be determined.

Assumptions 1 The heat engine operates steadily. 2 Heat losses from the working fluid at the pipes and other components are negligible.

Analysis Applying the definition of the thermal efficiency and an energy balance to the heat engine, the unknown parameters are determined as follows:

$$\eta_{\text{th,max}} = 1 - \frac{T_L}{T_H} = 1 - \frac{(50 + 273) \text{ K}}{(1200 + 273) \text{ K}} = 0.781$$

$$Q_H = \frac{W_{\text{net}}}{\eta_{\text{th}}} = \frac{500 \text{ kJ}}{0.781} = \mathbf{640 \text{ kJ}}$$

$$Q_L = Q_H - W_{\text{net}} = 640 - 500 = \mathbf{140 \text{ kJ}}$$

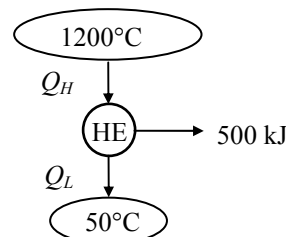

6-124E The operating conditions of a heat pump are given. The minimum temperature of the source that satisfies the second law of thermodynamics is to be determined.

Assumptions The heat pump operates steadily.

Analysis Applying the first law to this heat pump gives

$$\dot{Q}_L = \dot{Q}_H - \dot{W}_{\text{net,in}} = 32,000 \text{ Btu/h} - (1.8 \text{ kW}) \left(\frac{3412.14 \text{ Btu/h}}{1 \text{ kW}} \right) = 25,860 \text{ Btu/h}$$

In the reversible case we have

$$\frac{T_L}{T_H} = \frac{\dot{Q}_L}{\dot{Q}_H}$$

Then the minimum temperature may be determined to be

$$T_L = T_H \frac{\dot{Q}_L}{\dot{Q}_H} = (530 \text{ R}) \frac{25,860 \text{ Btu/h}}{32,000 \text{ Btu/h}} = \mathbf{428 \text{ R}}$$

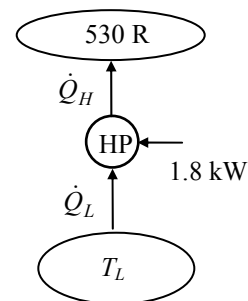

6-125 A heat pump with a specified COP is to heat a house. The rate of heat loss of the house and the power consumption of the heat pump are given. The time it will take for the interior temperature to rise from 3°C to 22°C is to be determined.

Assumptions 1 Air is an ideal gas with constant specific heats at room temperature. **2** The house is well-sealed so that no air leaks in or out. **3** The COP of the heat pump remains constant during operation.

Properties The constant volume specific heat of air at room temperature is $c_v = 0.718 \text{ kJ/kg}\cdot^\circ\text{C}$ (Table A-2)

Analysis The house is losing heat at a rate of

$$\dot{Q}_{\text{Loss}} = 40,000 \text{ kJ/h} = 11.11 \text{ kJ/s}$$

The rate at which this heat pump supplies heat is

$$\dot{Q}_H = \text{COP}_{\text{HP}} \dot{W}_{\text{net,in}} = (2.4)(8 \text{ kW}) = 19.2 \text{ kW}$$

That is, this heat pump can supply heat at a rate of 19.2 kJ/s. Taking the house as the system (a closed system), the energy balance can be written as

$$\underbrace{E_{\text{in}} - E_{\text{out}}}_{\text{Net energy transfer by heat, work, and mass}} = \underbrace{\Delta E_{\text{system}}}_{\text{Change in internal, kinetic, potential, etc. energies}}$$

$$Q_{\text{in}} - Q_{\text{out}} = \Delta U = m(u_2 - u_1)$$

$$Q_{\text{in}} - Q_{\text{out}} = mc_v(T_2 - T_1)$$

$$(\dot{Q}_{\text{in}} - \dot{Q}_{\text{out}})\Delta t = mc_v(T_2 - T_1)$$

Substituting,

$$(19.2 - 11.11 \text{ kJ/s})\Delta t = (2000 \text{ kg})(0.718 \text{ kJ/kg}\cdot^\circ\text{C})(22 - 3)^\circ\text{C}$$

Solving for Δt , it will take

$$\Delta t = 3373 \text{ s} = \mathbf{0.937 \text{ h}}$$

for the temperature in the house to rise to 22°C.

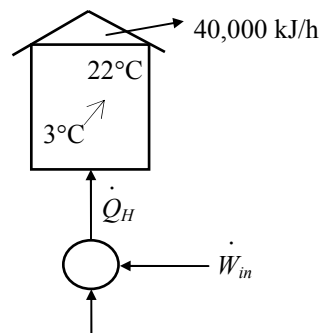

6-126E A refrigerator with a water-cooled condenser is considered. The cooling load and the COP of a refrigerator are given. The power input, the exit temperature of water, and the maximum possible COP of the refrigerator are to be determined.

Assumptions The refrigerator operates steadily.

Analysis (a) The power input is

$$\dot{W}_{\text{in}} = \frac{\dot{Q}_L}{\text{COP}} = \frac{24,000 \text{ Btu/h}}{1.77} \left(\frac{1.055 \text{ kJ}}{1 \text{ Btu}} \right) \left(\frac{1 \text{ h}}{3600 \text{ s}} \right) = \mathbf{3.974 \text{ kW}}$$

(b) The rate of heat rejected in the condenser is

$$\begin{aligned} \dot{Q}_H &= \dot{Q}_L + \dot{W}_{\text{in}} \\ &= 24,000 \text{ Btu/h} + 3.974 \text{ kW} \left(\frac{1 \text{ Btu}}{1.055 \text{ kJ}} \right) \left(\frac{3600 \text{ s}}{1 \text{ h}} \right) \\ &= 37,560 \text{ Btu/h} \end{aligned}$$

The exit temperature of the water is

$$\begin{aligned} \dot{Q}_H &= \dot{m} c_p (T_2 - T_1) \\ T_2 &= T_1 + \frac{\dot{Q}_H}{\dot{m} c_p} \\ &= 58^\circ\text{F} + \frac{37,560 \text{ Btu/h}}{(1.45 \text{ lbm/s}) \left(\frac{3600 \text{ s}}{1 \text{ h}} \right) (1.0 \text{ Btu/lbm} \cdot ^\circ\text{F})} = \mathbf{65.2^\circ\text{F}} \end{aligned}$$

(c) Taking the temperature of high-temperature medium to be the average temperature of water in the condenser,

$$\text{COP}_{\text{rev}} = \frac{T_L}{T_H - T_L} = \frac{25 + 460}{0.5(58 + 65.2) - 25} = \mathbf{13.3}$$

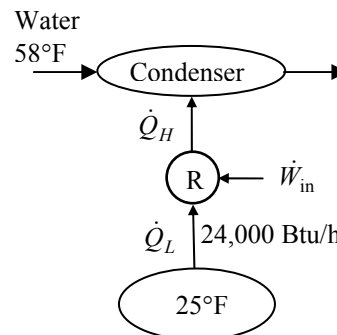

6-127 A Carnot heat engine cycle is executed in a closed system with a fixed mass of R-134a. The thermal efficiency of the cycle is given. The net work output of the engine is to be determined.

Assumptions All components operate steadily.

Properties The enthalpy of vaporization of R-134a at 50°C is $h_{fg} = 151.79 \text{ kJ/kg}$ (Table A-11).

Analysis The enthalpy of vaporization h_{fg} at a given T or P represents the amount of heat transfer as 1 kg of a substance is converted from saturated liquid to saturated vapor at that T or P . Therefore, the amount of heat transfer to R-134a during the heat addition process of the cycle is

$$Q_H = m h_{fg@50^\circ\text{C}} = (0.01 \text{ kg})(151.79 \text{ kJ/kg}) = 1.518 \text{ kJ}$$

Then the work output of this heat engine becomes

$$W_{\text{net,out}} = \eta_{\text{th}} Q_H = (0.15)(1.518 \text{ kJ}) = \mathbf{0.228 \text{ kJ}}$$

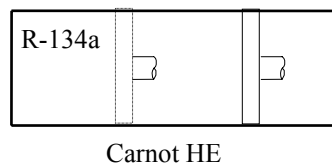

6-128 A heat pump with a specified COP and power consumption is used to heat a house. The time it takes for this heat pump to raise the temperature of a cold house to the desired level is to be determined.

Assumptions 1 Air is an ideal gas with constant specific heats at room temperature. **2** The heat loss of the house during the warm-up period is negligible. **3** The house is well-sealed so that no air leaks in or out.

Properties The constant volume specific heat of air at room temperature is $c_v = 0.718 \text{ kJ/kg} \cdot ^\circ\text{C}$.

Analysis Since the house is well-sealed (constant volume), the total amount of heat that needs to be supplied to the house is

$$Q_H = (mc_v \Delta T)_{\text{house}} = (1500 \text{ kg})(0.718 \text{ kJ/kg} \cdot ^\circ\text{C})(22 - 7)^\circ\text{C} = 16,155 \text{ kJ}$$

The rate at which this heat pump supplies heat is

$$\dot{Q}_H = \text{COP}_{\text{HP}} \dot{W}_{\text{net,in}} = (2.8)(5 \text{ kW}) = 14 \text{ kW}$$

That is, this heat pump can supply 14 kJ of heat per second. Thus the time required to supply 16,155 kJ of heat is

$$\Delta t = \frac{Q_H}{\dot{Q}_H} = \frac{16,155 \text{ kJ}}{14 \text{ kJ/s}} = 1154 \text{ s} = \mathbf{19.2 \text{ min}}$$

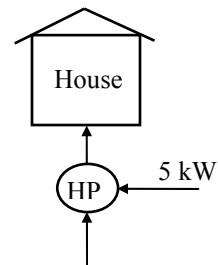

6-129 A solar pond power plant operates by absorbing heat from the hot region near the bottom, and rejecting waste heat to the cold region near the top. The maximum thermal efficiency that the power plant can have is to be determined.

Analysis The highest thermal efficiency a heat engine operating between two specified temperature limits can have is the Carnot efficiency, which is determined from

$$\eta_{\text{th,max}} = \eta_{\text{th,C}} = 1 - \frac{T_L}{T_H} = 1 - \frac{308 \text{ K}}{353 \text{ K}} = 0.127 \text{ or } \mathbf{12.7\%}$$

In reality, the temperature of the working fluid must be above 35°C in the condenser, and below 80°C in the boiler to allow for any effective heat transfer. Therefore, the maximum efficiency of the actual heat engine will be lower than the value calculated above.

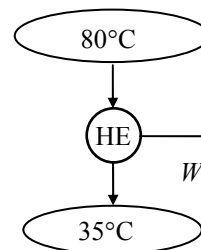

6-130 A Carnot heat engine cycle is executed in a closed system with a fixed mass of steam. The net work output of the cycle and the ratio of sink and source temperatures are given. The low temperature in the cycle is to be determined.

Assumptions The engine is said to operate on the Carnot cycle, which is totally reversible.

Analysis The thermal efficiency of the cycle is

$$\eta_{\text{th}} = 1 - \frac{T_L}{T_H} = 1 - \frac{1}{2} = 0.5$$

Also,

$$\eta_{\text{th}} = \frac{W}{Q_H} \longrightarrow Q_H = \frac{W}{\eta_{\text{th}}} = \frac{60 \text{ kJ}}{0.5} = 120 \text{ kJ}$$

$$Q_L = Q_H - W = 120 - 60 = 60 \text{ kJ}$$

and

$$q_L = \frac{Q_L}{m} = \frac{60 \text{ kJ}}{0.025 \text{ kg}} = 2400 \text{ kJ/kg} = h_{fg@T_L}$$

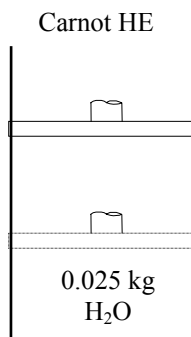

since the enthalpy of vaporization h_{fg} at a given T or P represents the amount of heat transfer as 1 kg of a substance is converted from saturated liquid to saturated vapor at that T or P . Therefore, T_L is the temperature that corresponds to the h_{fg} value of 2400 kJ/kg, and is determined from the steam tables (Table A-4) to be

$$T_L = \mathbf{42.5^\circ\text{C}}$$



6-131 Problem 6-130 is reconsidered. The effect of the net work output on the required temperature of the steam during the heat rejection process as the work output varies from 40 kJ to 60 kJ is to be investigated.

Analysis The problem is solved using EES, and the results are tabulated and plotted below.

"Given"

$$m=0.025 \text{ [kg]}$$

$$\text{RatioT}=0.5 \text{ "RatioT=T_L/T_H"}$$

$$\text{"W_net_out}=60 \text{ [kJ]}$$

"Properties"

$$\text{Fluid\$}=' \text{steam_iapws}'$$

$$h_f=\text{enthalpy}(\text{Fluid\$}, T=T_L, x=0)$$

$$h_g=\text{enthalpy}(\text{Fluid\$}, T=T_L, x=1)$$

$$h_{fg}=h_g-h_f$$

"Analysis"

$$\text{eta_th}=1-\text{RatioT}$$

$$\text{eta_th}=\text{W_net_out}/\text{Q_H}$$

$$\text{Q_L}=\text{Q_H}-\text{W_net_out}$$

$$\text{Q_L}=m*h_{fg}$$

| W_{out} [kJ] | $T_{L,C}$ [C] |
|--------------------------|------------------|
| 40 | 270.8 |
| 42.5 | 252.9 |
| 45 | 232.8 |
| 47.5 | 209.9 |
| 50 | 184 |
| 52.5 | 154.4 |
| 55 | 120.8 |
| 57.5 | 83.17 |
| 60 | 42.5 |

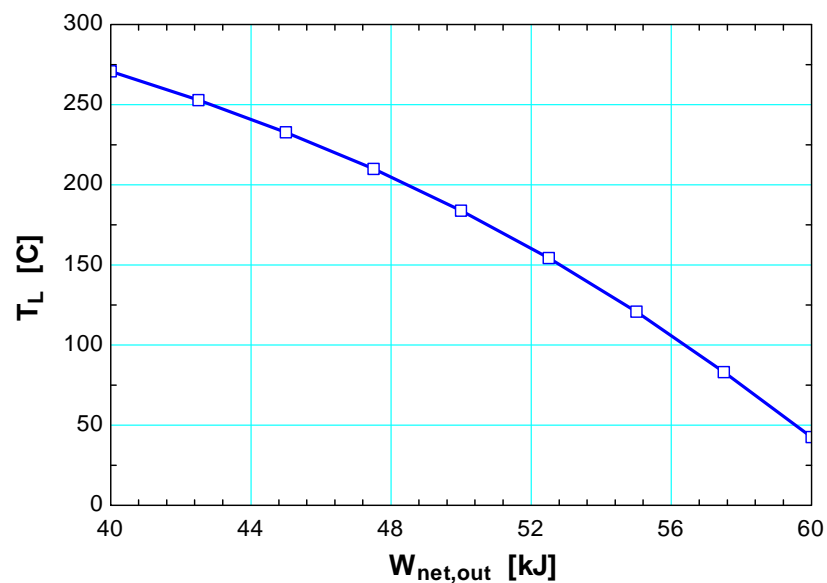

6-132 A Carnot refrigeration cycle is executed in a closed system with a fixed mass of R-134a. The net work input and the ratio of maximum-to-minimum temperatures are given. The minimum pressure in the cycle is to be determined.

Assumptions The refrigerator is said to operate on the reversed Carnot cycle, which is totally reversible.

Analysis The coefficient of performance of the cycle is

$$\text{COP}_R = \frac{1}{T_H / T_L - 1} = \frac{1}{1.2 - 1} = 5$$

Also,

$$\text{COP}_R = \frac{Q_L}{W_{\text{in}}} \longrightarrow Q_L = \text{COP}_R \times W_{\text{in}} = (5)(22 \text{ kJ}) = 110 \text{ kJ}$$

$$Q_H = Q_L + W = 110 + 22 = 132 \text{ kJ}$$

and

$$q_H = \frac{Q_H}{m} = \frac{132 \text{ kJ}}{0.96 \text{ kg}} = 137.5 \text{ kJ/kg} = h_{fg@T_H}$$

since the enthalpy of vaporization h_{fg} at a given T or P represents the amount of heat transfer per unit mass as a substance is converted from saturated liquid to saturated vapor at that T or P . Therefore, T_H is the temperature that corresponds to the h_{fg} value of 137.5 kJ/kg, and is determined from the R-134a tables to be

$$T_H \cong 61.3^\circ\text{C} = 334.3 \text{ K}$$

Then,

$$T_L = \frac{T_H}{1.2} = \frac{334.3 \text{ K}}{1.2} = 278.6 \text{ K} \cong 5.6^\circ\text{C}$$

Therefore,

$$P_{\text{min}} = P_{\text{sat}@5.6^\circ\text{C}} = \mathbf{355 \text{ kPa}}$$

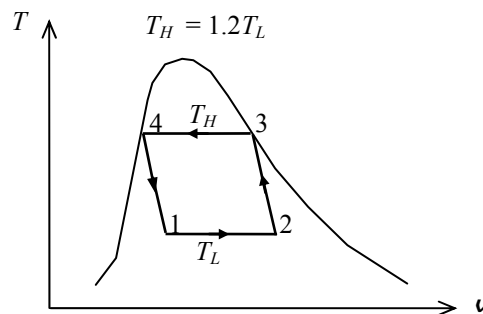



6-133 Problem 6-132 is reconsidered. The effect of the net work input on the minimum pressure as the work input varies from 10 kJ to 30 kJ is to be investigated. The minimum pressure in the refrigeration cycle is to be plotted as a function of net work input.

Analysis The problem is solved using EES, and the results are tabulated and plotted below.

Analysis: The coefficient of performance of the cycle is given by"

$$m_{R134a} = 0.96 \text{ [kg]}$$

$$THtoTLRatio = 1.2 \quad "T_H = 1.2T_L"$$

$$"W_{in} = 22 \text{ [kJ]} \quad "Depending on the value of W_{in}, adjust the guess value of T_H."$$

$$COP_R = 1 / (THtoTLRatio - 1)$$

$$Q_L = W_{in} * COP_R$$

"First law applied to the refrigeration cycle yields:"

$$Q_L + W_{in} = Q_H$$

"Steady-flow analysis of the condenser yields

$$m_{R134a} * h_3 = m_{R134a} * h_4 + Q_H$$

$$Q_H = m_{R134a} * (h_3 - h_4) \quad \text{and} \quad h_{fg} = h_3 - h_4 \quad \text{also} \quad T_H = T_3 = T_4"$$

$$Q_H = m_{R134a} * h_{fg}$$

$$h_{fg} = \text{enthalpy}(R134a, T=T_H, x=1) - \text{enthalpy}(R134a, T=T_H, x=0)$$

$$T_H = THtoTLRatio * T_L$$

"The minimum pressure is the saturation pressure corresponding to T_L ."

$$P_{min} = \text{pressure}(R134a, T=T_L, x=0) * \text{convert}(kPa, MPa)$$

$$T_{L,C} = T_L - 273$$

| W_{in} [kJ] | P_{min} [MPa] | T_H [K] | T_L [K] | $T_{L,C}$ [C] |
|------------------|--------------------|--------------|--------------|------------------|
| 10 | 0.8673 | 368.8 | 307.3 | 34.32 |
| 15 | 0.6837 | 358.9 | 299 | 26.05 |
| 20 | 0.45 | 342.7 | 285.6 | 12.61 |
| 25 | 0.2251 | 319.3 | 266.1 | -6.907 |
| 30 | 0.06978 | 287.1 | 239.2 | -33.78 |

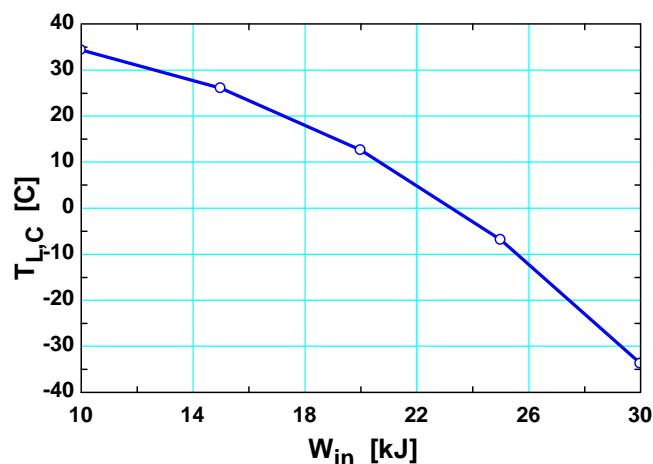
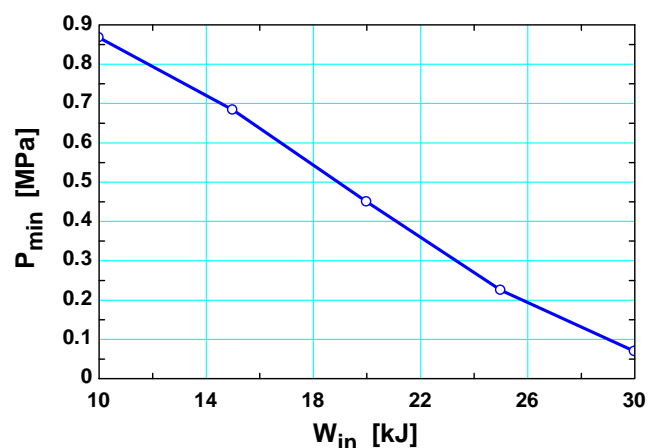

6-134 Two Carnot heat engines operate in series between specified temperature limits. If the thermal efficiencies of both engines are the same, the temperature of the intermediate medium between the two engines is to be determined.

Assumptions The engines are said to operate on the Carnot cycle, which is totally reversible.

Analysis The thermal efficiency of the two Carnot heat engines can be expressed as

$$\eta_{\text{th,I}} = 1 - \frac{T}{T_H} \quad \text{and} \quad \eta_{\text{th,II}} = 1 - \frac{T_L}{T}$$

Equating,

$$1 - \frac{T}{T_H} = 1 - \frac{T_L}{T}$$

Solving for T ,

$$T = \sqrt{T_H T_L} = \sqrt{(1800 \text{ K})(300 \text{ K})} = \mathbf{735 \text{ K}}$$

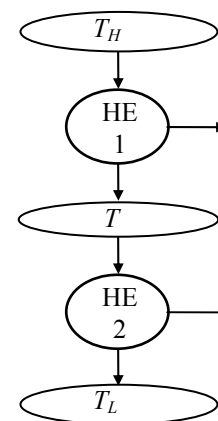

6-135E The thermal efficiency of a completely reversible heat engine as a function of the source temperature is to be calculated and plotted.

Assumptions The heat engine operates steadily.

Analysis With the specified sink temperature, the thermal efficiency of this completely reversible heat engine is

$$\eta_{\text{th,rev}} = 1 - \frac{T_L}{T_H} = 1 - \frac{500 \text{ R}}{T_H}$$

Using EES, we tabulate and plot the variation of thermal efficiency with the source temperature:

| T_H [R] | $\eta_{\text{th,rev}}$ |
|-----------|------------------------|
| 500 | 0 |
| 650 | 0.2308 |
| 800 | 0.375 |
| 950 | 0.4737 |
| 1100 | 0.5455 |
| 1250 | 0.6 |
| 1400 | 0.6429 |
| 1550 | 0.6774 |
| 1700 | 0.7059 |
| 1850 | 0.7297 |
| 2000 | 0.75 |

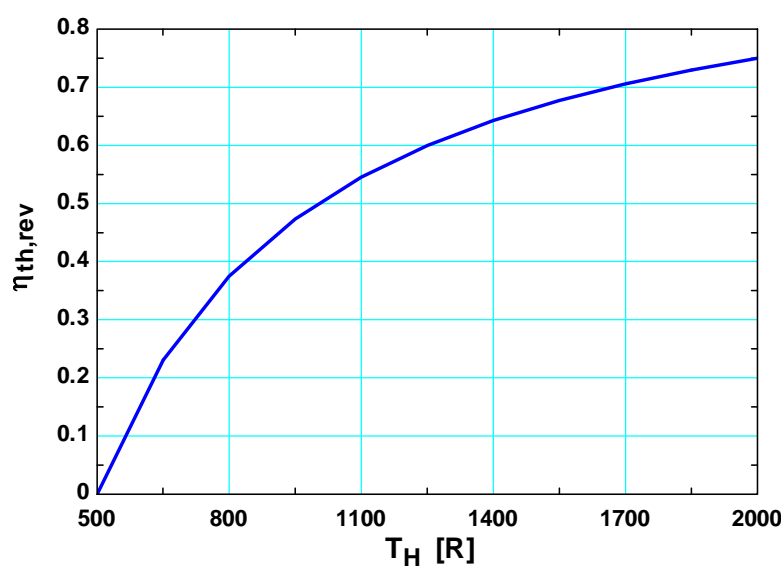

6-136 A Carnot heat engine drives a Carnot refrigerator that removes heat from a cold medium at a specified rate. The rate of heat supply to the heat engine and the total rate of heat rejection to the environment are to be determined.

Analysis (a) The coefficient of performance of the Carnot refrigerator is

$$\text{COP}_{R,C} = \frac{1}{(T_H/T_L) - 1} = \frac{1}{(300 \text{ K})/(258 \text{ K}) - 1} = 6.143$$

Then power input to the refrigerator becomes

$$\dot{W}_{\text{net,in}} = \frac{\dot{Q}_L}{\text{COP}_{R,C}} = \frac{250 \text{ kJ/min}}{6.143} = 40.7 \text{ kJ/min}$$

which is equal to the power output of the heat engine, $\dot{W}_{\text{net,out}}$.

The thermal efficiency of the Carnot heat engine is determined from

$$\eta_{\text{th,C}} = 1 - \frac{T_L}{T_H} = 1 - \frac{300 \text{ K}}{900 \text{ K}} = 0.6667$$

Then the rate of heat input to this heat engine is determined from the definition of thermal efficiency to be

$$\dot{Q}_{H,HE} = \frac{\dot{W}_{\text{net,out}}}{\eta_{\text{th,HE}}} = \frac{40.7 \text{ kJ/min}}{0.6667} = \mathbf{61.1 \text{ kJ/min}}$$

(b) The total rate of heat rejection to the ambient air is the sum of the heat rejected by the heat engine ($\dot{Q}_{L,HE}$) and the heat discarded by the refrigerator ($\dot{Q}_{H,R}$),

$$\dot{Q}_{L,HE} = \dot{Q}_{H,HE} - \dot{W}_{\text{net,out}} = 61.1 - 40.7 = 20.4 \text{ kJ/min}$$

$$\dot{Q}_{H,R} = \dot{Q}_{L,R} + \dot{W}_{\text{net,in}} = 250 + 40.7 = 290.7 \text{ kJ/min}$$

and

$$\dot{Q}_{\text{Ambient}} = \dot{Q}_{L,HE} + \dot{Q}_{H,R} = 20.4 + 290.7 = \mathbf{311 \text{ kJ/min}}$$

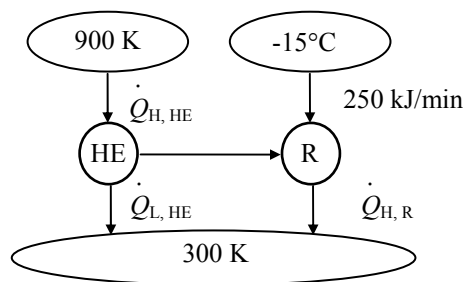



6-137 Problem 6-136 is reconsidered. The effects of the heat engine source temperature, the environment temperature, and the cooled space temperature on the required heat supply to the heat engine and the total rate of heat rejection to the environment as the source temperature varies from 500 K to 1000 K, the environment temperature varies from 275 K to 325 K, and the cooled space temperature varies from -20°C to 0°C are to be investigated. The required heat supply is to be plotted against the source temperature for the cooled space temperature of -15°C and environment temperatures of 275, 300, and 325 K.

Analysis The problem is solved using EES, and the results are tabulated and plotted below.

$Q_{\text{dot}_L_R} = 250 \text{ [kJ/min]}$
 $T_{\text{surr}} = 300 \text{ [K]}$
 $T_H = 900 \text{ [K]}$
 $T_{L_C} = -15 \text{ [C]}$
 $T_L = T_{L_C} + 273$

"Coefficient of performance of the Carnot refrigerator:"

$T_{H_R} = T_{\text{surr}}$
 $\text{COP}_R = 1/(T_{H_R}/T_L - 1)$

"Power input to the refrigerator:"

$W_{\text{dot}_in_R} = Q_{\text{dot}_L_R}/\text{COP}_R$

"Power output from heat engine must be:"

$W_{\text{dot}_out_{HE}} = W_{\text{dot}_in_R}$

"The efficiency of the heat engine is:"

$T_{L_{HE}} = T_{\text{surr}}$
 $\eta_{HE} = 1 - T_{L_{HE}}/T_H$

"The rate of heat input to the heat engine is:"

$Q_{\text{dot}_H_{HE}} = W_{\text{dot}_out_{HE}}/\eta_{HE}$

"First law applied to the heat engine and refrigerator:"

$Q_{\text{dot}_L_{HE}} = Q_{\text{dot}_H_{HE}} - W_{\text{dot}_out_{HE}}$

$Q_{\text{dot}_H_R} = Q_{\text{dot}_L_R} + W_{\text{dot}_in_R}$

| T_H [K] | Q_{HHE} [kJ/min] | Q_{surr} [kJ/min] |
|--------------|-----------------------|-------------------------------|
| 500 | 36.61 | 286.6 |
| 600 | 30.41 | 280.4 |
| 700 | 27.13 | 277.1 |
| 800 | 25.1 | 275.1 |
| 900 | 23.72 | 273.7 |
| 1000 | 22.72 | 272.7 |

| T_{L_C} [C] | Q_{HHE} [kJ/min] | Q_{surr} [kJ/min] |
|------------------|-----------------------|-------------------------------|
| -20 | 31.3 | 281.3 |
| -18 | 28.24 | 278.2 |
| -16 | 25.21 | 275.2 |
| -14 | 22.24 | 272.2 |
| -12 | 19.31 | 269.3 |
| -10 | 16.43 | 266.4 |
| -8 | 13.58 | 263.6 |
| -6 | 10.79 | 260.8 |
| -4 | 8.03 | 258 |
| -2 | 5.314 | 255.3 |
| 0 | 2.637 | 252.6 |

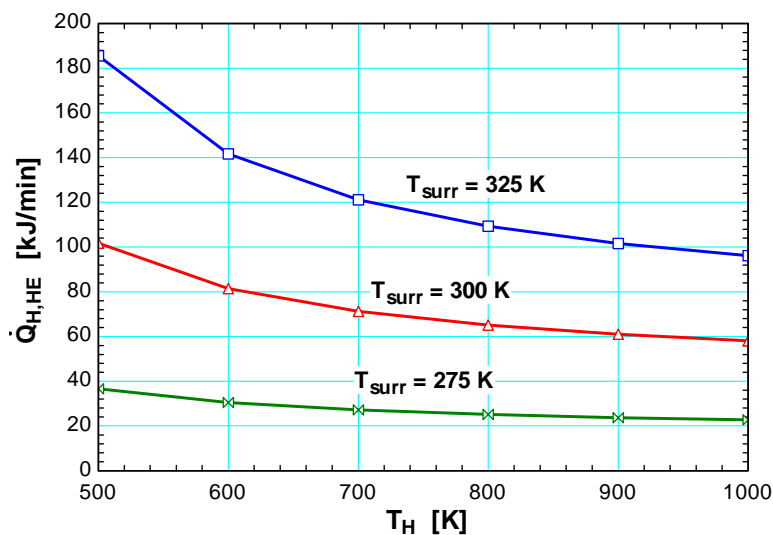

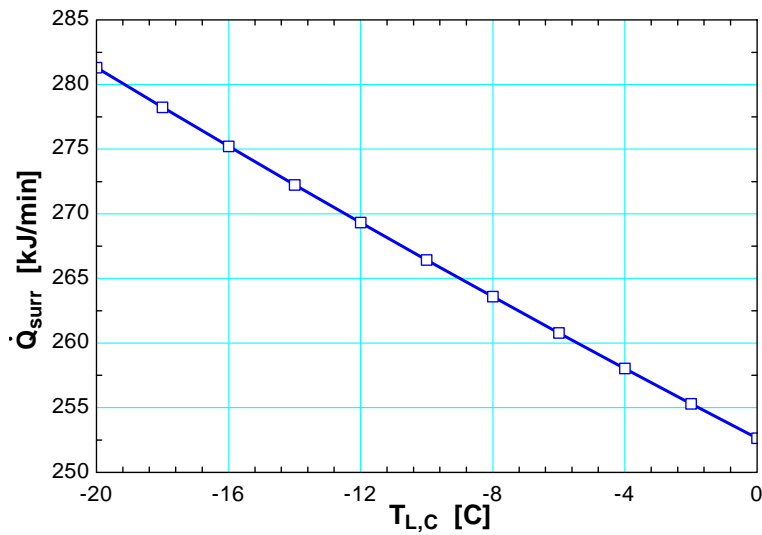
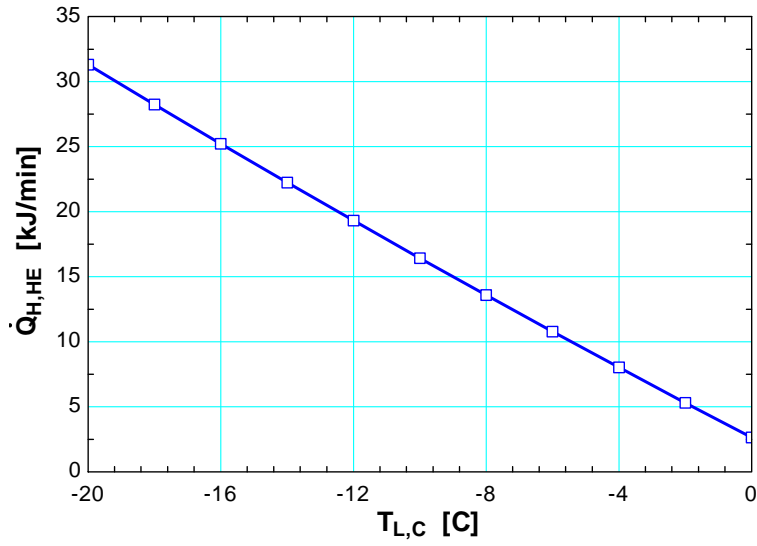
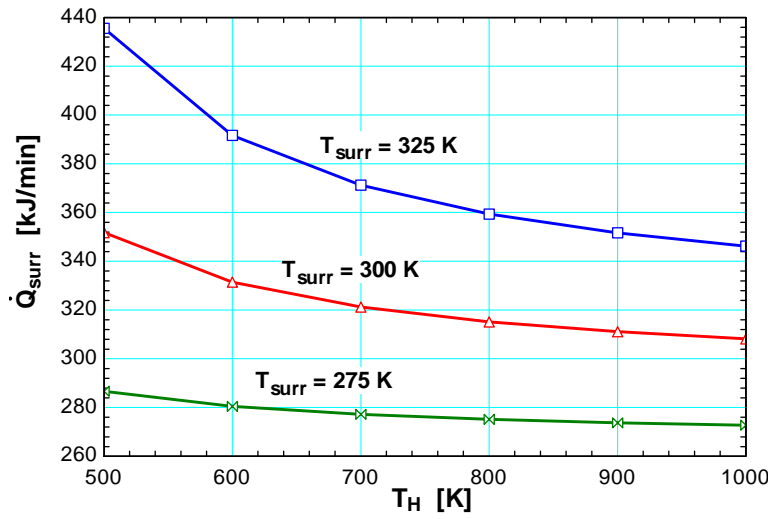

6-138 Half of the work output of a Carnot heat engine is used to drive a Carnot heat pump that is heating a house. The minimum rate of heat supply to the heat engine is to be determined.

Assumptions Steady operating conditions exist.

Analysis The coefficient of performance of the Carnot heat pump is

$$\text{COP}_{\text{HP,C}} = \frac{1}{1 - (T_L/T_H)} = \frac{1}{1 - (2 + 273 \text{ K})/(22 + 273 \text{ K})} = 14.75$$

Then power input to the heat pump, which is supplying heat to the house at the same rate as the rate of heat loss, becomes

$$\dot{W}_{\text{net,in}} = \frac{\dot{Q}_H}{\text{COP}_{\text{HP,C}}} = \frac{62,000 \text{ kJ/h}}{14.75} = 4203 \text{ kJ/h}$$

which is half the power produced by the heat engine. Thus the power output of the heat engine is

$$\dot{W}_{\text{net,out}} = 2\dot{W}_{\text{net,in}} = 2(4203 \text{ kJ/h}) = 8406 \text{ kJ/h}$$

To minimize the rate of heat supply, we must use a Carnot heat engine whose thermal efficiency is determined from

$$\eta_{\text{th,C}} = 1 - \frac{T_L}{T_H} = 1 - \frac{293 \text{ K}}{1073 \text{ K}} = 0.727$$

Then the rate of heat supply to this heat engine is determined from the definition of thermal efficiency to be

$$\dot{Q}_{H,\text{HE}} = \frac{\dot{W}_{\text{net,out}}}{\eta_{\text{th,HE}}} = \frac{8406 \text{ kJ/h}}{0.727} = \mathbf{11,560 \text{ kJ/h}}$$

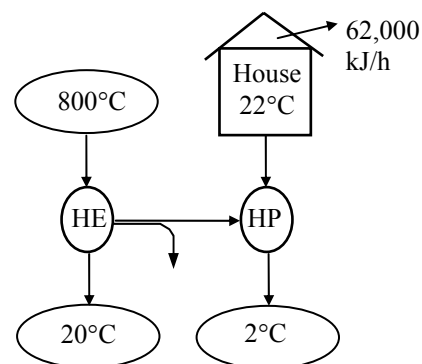

6-139E An extraordinary claim made for the performance of a refrigerator is to be evaluated.

Assumptions Steady operating conditions exist.

Analysis The performance of this refrigerator can be evaluated by comparing it with a reversible refrigerator operating between the same temperature limits:

$$\text{COP}_{\text{R,max}} = \text{COP}_{\text{R,rev}} = \frac{1}{T_H/T_L - 1} = \frac{1}{(75 + 460)/(35 + 460) - 1} = 12.4$$

Discussion This is the highest COP a refrigerator can have when absorbing heat from a cool medium at 35°F and rejecting it to a warmer medium at 75°F. Since the COP claimed by the inventor is above this maximum value, **the claim is false**.

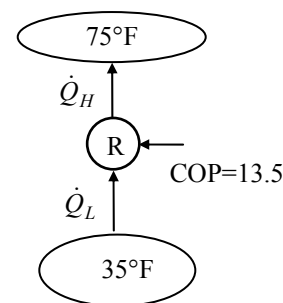

6-140 A Carnot heat pump cycle is executed in a steady-flow system with R-134a flowing at a specified rate. The net power input and the ratio of the maximum-to-minimum temperatures are given. The ratio of the maximum to minimum pressures is to be determined.

Analysis The coefficient of performance of the cycle is

$$\text{COP}_{\text{HP}} = \frac{1}{1 - T_L / T_H} = \frac{1}{1 - 1/1.2} = 6.0$$

and

$$\dot{Q}_H = \text{COP}_{\text{HP}} \times \dot{W}_{\text{in}} = (6.0)(5 \text{ kW}) = 30.0 \text{ kJ/s}$$

$$q_H = \frac{\dot{Q}_H}{\dot{m}} = \frac{30.0 \text{ kJ/s}}{0.22 \text{ kg/s}} = 136.36 \text{ kJ/kg} = h_{fg@T_H}$$

since the enthalpy of vaporization h_{fg} at a given T or P represents the amount of heat transfer per unit mass as a substance is converted from saturated liquid to saturated vapor at that T or P . Therefore, T_H is the temperature that corresponds to the h_{fg} value of 136.36 kJ/kg, and is determined from the R-134a tables to be

$$T_H \cong 62.0^\circ\text{C} = 335.1 \text{ K}$$

and

$$P_{\text{max}} = P_{\text{sat}@62.0^\circ\text{C}} = 1763 \text{ kPa}$$

$$T_L = \frac{T_H}{1.25} = \frac{335.1 \text{ K}}{1.2} = 291.4 \text{ K} \cong 18.3^\circ\text{C}$$

Also,

$$P_{\text{min}} = P_{\text{sat}@18.3^\circ\text{C}} = 542 \text{ kPa}$$

Then the ratio of the maximum to minimum pressures in the cycle is

$$\frac{P_{\text{max}}}{P_{\text{min}}} = \frac{1763 \text{ kPa}}{542 \text{ kPa}} = \mathbf{3.25}$$

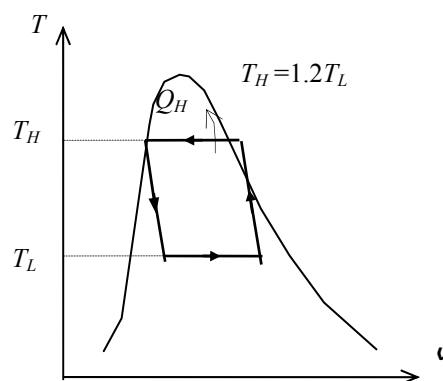

6-141 Switching to energy efficient lighting reduces the electricity consumed for lighting as well as the cooling load in summer, but increases the heating load in winter. It is to be determined if switching to efficient lighting will increase or decrease the total energy cost of a building.

Assumptions The light escaping through the windows is negligible so that the entire lighting energy becomes part of the internal heat generation.

Analysis (a) Efficient lighting reduces the amount of electrical energy used for lighting year-around as well as the amount of heat generation in the house since light is eventually converted to heat. As a result, the electrical energy needed to air condition the house is also reduced. Therefore, in summer, the total cost of energy use of the household definitely decreases.

(b) In winter, the heating system must make up for the reduction in the heat generation due to reduced energy used for lighting. The total cost of energy used in this case will still decrease if the cost of unit heat energy supplied by the heating system is less than the cost of unit energy provided by lighting.

The cost of 1 kWh heat supplied from lighting is \$0.08 since all the energy consumed by lamps is eventually converted to thermal energy. Noting that 1 therm = 105,500 kJ = 29.3 kWh and the furnace is 80% efficient, the cost of 1 kWh heat supplied by the heater is

$$\begin{aligned}\text{Cost of 1 kWh heat supplied by furnace} &= (\text{Amount of useful energy}/\eta_{\text{furnace}})(\text{Price}) \\ &= [(1 \text{ kWh})/0.80](\$1.40/\text{therm})\left(\frac{1 \text{ therm}}{29.3 \text{ kWh}}\right) \\ &= \$0.060 \text{ (per kWh heat)}\end{aligned}$$



which is less than \$0.08. Thus we conclude that switching to energy efficient lighting will **reduce** the total energy cost of this building both in summer and in winter.

Discussion To determine the amount of cost savings due to switching to energy efficient lighting, consider 10 h of operation of lighting in summer and in winter for 1 kW rated power for lighting.

Current lighting:

Lighting cost: (Energy used)(Unit cost) = (1 kW)(10 h)(\$0.08/kWh) = \$0.80

Increase in air conditioning cost: (Heat from lighting/COP)(unit cost) = (10 kWh/3.5)(\$0.08/kWh) = \$0.23

Decrease in the heating cost = [Heat from lighting/Eff](unit cost) = (10/0.8 kWh)(\$1.40/29.3/kWh) = \$0.60

Total cost in summer = 0.80 + 0.23 = \$1.03; Total cost in winter = \$0.80 - 0.60 = 0.20.

Energy efficient lighting:

Lighting cost: (Energy used)(Unit cost) = (0.25 kW)(10 h)(\$0.08/kWh) = \$0.20

Increase in air conditioning cost: (Heat from lighting/COP)(unit cost) = (2.5 kWh/3.5)(\$0.08/kWh) = \$0.06

Decrease in the heating cost = [Heat from lighting/Eff](unit cost) = (2.5/0.8 kWh)(\$1.40/29.3/kWh) = \$0.15

Total cost in summer = 0.20 + 0.06 = \$0.26; Total cost in winter = \$0.20 - 0.15 = 0.05.

Note that during a day with 10 h of operation, the total energy cost decreases from \$1.03 to \$0.26 in summer, and from \$0.20 to \$0.05 in winter when efficient lighting is used.

6-142 A heat pump is used to heat a house. The maximum money saved by using the lake water instead of outside air as the heat source is to be determined.

Assumptions 1 Steady operating conditions exist. 2 The kinetic and potential energy changes are zero.

Analysis When outside air is used as the heat source, the cost of energy is calculated considering a reversible heat pump as follows:

$$\text{COP}_{\max} = \frac{1}{1 - T_L / T_H} = \frac{1}{1 - (0 + 273) / (25 + 273)} = 11.92$$

$$\dot{W}_{\text{in, min}} = \frac{\dot{Q}_H}{\text{COP}_{\max}} = \frac{(140,000 / 3600) \text{ kW}}{11.92} = 3.262 \text{ kW}$$

$$\text{Cost}_{\text{air}} = (3.262 \text{ kW})(100 \text{ h})(\$0.085/\text{kWh}) = \$27.73$$

Repeating calculations for lake water,

$$\text{COP}_{\max} = \frac{1}{1 - T_L / T_H} = \frac{1}{1 - (10 + 273) / (25 + 273)} = 19.87$$

$$\dot{W}_{\text{in, min}} = \frac{\dot{Q}_H}{\text{COP}_{\max}} = \frac{(140,000 / 3600) \text{ kW}}{19.87} = 1.957 \text{ kW}$$

$$\text{Cost}_{\text{lake}} = (1.957 \text{ kW})(100 \text{ h})(\$0.085/\text{kWh}) = \$16.63$$

Then the money saved becomes

$$\text{Money Saved} = \text{Cost}_{\text{air}} - \text{Cost}_{\text{lake}} = \$27.73 - \$16.63 = \mathbf{\$11.10}$$

6-143 The cargo space of a refrigerated truck is to be cooled from 25°C to an average temperature of 5°C. The time it will take for an 8-kW refrigeration system to precool the truck is to be determined.

Assumptions 1 The ambient conditions remain constant during precooling. **2** The doors of the truck are tightly closed so that the infiltration heat gain is negligible. **3** The air inside is sufficiently dry so that the latent heat load on the refrigeration system is negligible. **4** Air is an ideal gas with constant specific heats.

Properties The density of air is taken 1.2 kg/m³, and its specific heat at the average temperature of 15°C is $c_p = 1.0$ kJ/kg·°C (Table A-2).

Analysis The mass of air in the truck is

$$m_{\text{air}} = \rho_{\text{air}} V_{\text{truck}} = (1.2 \text{ kg/m}^3)(12 \text{ m} \times 2.3 \text{ m} \times 3.5 \text{ m}) = 116 \text{ kg}$$

The amount of heat removed as the air is cooled from 25 to 5°C

$$\begin{aligned} Q_{\text{cooling,air}} &= (mc_p \Delta T)_{\text{air}} = (116 \text{ kg})(1.0 \text{ kJ/kg} \cdot ^\circ\text{C})(25 - 5)^\circ\text{C} \\ &= 2,320 \text{ kJ} \end{aligned}$$

Noting that UA is given to be 80 W/°C and the average air temperature in the truck during precooling is $(25+5)/2 = 15^\circ\text{C}$, the average rate of heat gain by transmission is determined to be

$$\dot{Q}_{\text{transmission,ave}} = UA\Delta T = (80 \text{ W/}^\circ\text{C})(25 - 15)^\circ\text{C} = 800 \text{ W} = 0.80 \text{ kJ/s}$$

Therefore, the time required to cool the truck from 25 to 5°C is determined to be

$$\begin{aligned} \dot{Q}_{\text{refrig.}} \Delta t &= Q_{\text{cooling,air}} + \dot{Q}_{\text{transmission}} \Delta t \\ \longrightarrow \Delta t &= \frac{Q_{\text{cooling,air}}}{\dot{Q}_{\text{refrig.}} - \dot{Q}_{\text{transmission}}} = \frac{2,320 \text{ kJ}}{(8 - 0.8) \text{ kJ/s}} = 322 \text{ s} \cong \mathbf{5.4 \text{ min}} \end{aligned}$$

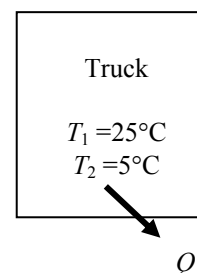

6-144 A refrigeration system is to cool bread loaves at a rate of 1200 per hour by refrigerated air at -30°C . The rate of heat removal from the breads, the required volume flow rate of air, and the size of the compressor of the refrigeration system are to be determined.

Assumptions 1 Steady operating conditions exist. 2 The thermal properties of the bread loaves are constant. 3 The cooling section is well-insulated so that heat gain through its walls is negligible.

Properties The average specific and latent heats of bread are given to be $2.93\text{ kJ/kg}\cdot^{\circ}\text{C}$ and 109.3 kJ/kg , respectively. The gas constant of air is $0.287\text{ kPa}\cdot\text{m}^3/\text{kg}\cdot\text{K}$ (Table A-1), and the specific heat of air at the average temperature of $(-30 + -22)/2 = -26^{\circ}\text{C} \approx 250\text{ K}$ is $c_p = 1.0\text{ kJ/kg}\cdot^{\circ}\text{C}$ (Table A-2).

Analysis (a) Noting that the breads are cooled at a rate of 500 loaves per hour, breads can be considered to flow steadily through the cooling section at a mass flow rate of

$$\dot{m}_{\text{bread}} = (1200\text{ breads/h})(0.350\text{ kg/bread}) = 420\text{ kg/h} = 0.1167\text{ kg/s}$$

Then the rate of heat removal from the breads as they are cooled from 30°C to -10°C and frozen becomes

$$\dot{Q}_{\text{bread}} = (\dot{m}c_p\Delta T)_{\text{bread}} = (420\text{ kg/h})(2.93\text{ kJ/kg}\cdot^{\circ}\text{C})[(30 - (-10))^{\circ}\text{C}] = 49,224\text{ kJ/h}$$

$$\dot{Q}_{\text{freezing}} = (\dot{m}h_{\text{latent}})_{\text{bread}} = (420\text{ kg/h})(109.3\text{ kJ/kg}) = 45,906\text{ kJ/h}$$

and

$$\dot{Q}_{\text{total}} = \dot{Q}_{\text{bread}} + \dot{Q}_{\text{freezing}} = 49,224 + 45,906 = \mathbf{95,130\text{ kJ/h}}$$

(b) All the heat released by the breads is absorbed by the refrigerated air, and the temperature rise of air is not to exceed 8°C . The minimum mass flow and volume flow rates of air are determined to be

$$\dot{m}_{\text{air}} = \frac{\dot{Q}_{\text{air}}}{(c_p\Delta T)_{\text{air}}} = \frac{95,130\text{ kJ/h}}{(1.0\text{ kJ/kg}\cdot^{\circ}\text{C})(8^{\circ}\text{C})} = 11,891\text{ kg/h}$$

$$\rho = \frac{P}{RT} = \frac{101.3\text{ kPa}}{(0.287\text{ kPa}\cdot\text{m}^3/\text{kg}\cdot\text{K})(-30 + 273)\text{ K}} = 1.453\text{ kg/m}^3$$

$$\dot{V}_{\text{air}} = \frac{\dot{m}_{\text{air}}}{\rho_{\text{air}}} = \frac{11,891\text{ kg/h}}{1.453\text{ kg/m}^3} = \mathbf{8185\text{ m}^3/\text{h}}$$

(c) For a COP of 1.2, the size of the compressor of the refrigeration system must be

$$\dot{W}_{\text{refrig}} = \frac{\dot{Q}_{\text{refrig}}}{\text{COP}} = \frac{95,130\text{ kJ/h}}{1.2} = 79,275\text{ kJ/h} = \mathbf{22.02\text{ kW}}$$

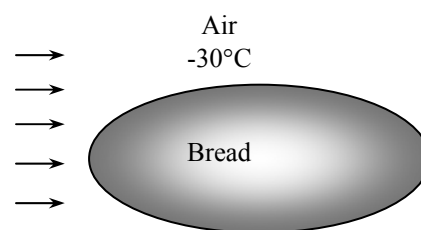

6-145 The drinking water needs of a production facility with 20 employees is to be met by a bobble type water fountain. The size of compressor of the refrigeration system of this water cooler is to be determined.

Assumptions 1 Steady operating conditions exist. 2 Water is an incompressible substance with constant properties at room temperature. 3 The cold water requirement is 0.4 L/h per person.

Properties The density and specific heat of water at room temperature are $\rho = 1.0 \text{ kg/L}$ and $c = 4.18 \text{ kJ/kg}\cdot^\circ\text{C}$ (Table A-3).

Analysis The refrigeration load in this case consists of the heat gain of the reservoir and the cooling of the incoming water. The water fountain must be able to provide water at a rate of

$$\dot{m}_{\text{water}} = \rho \dot{V}_{\text{water}} = (1 \text{ kg/L})(0.4 \text{ L/h} \cdot \text{person})(20 \text{ persons}) = 8.0 \text{ kg/h}$$

To cool this water from 22°C to 8°C , heat must be removed from the water at a rate of

$$\begin{aligned} \dot{Q}_{\text{cooling}} &= \dot{m}c_p(T_{\text{in}} - T_{\text{out}}) \\ &= (8.0 \text{ kg/h})(4.18 \text{ kJ/kg}\cdot^\circ\text{C})(22 - 8)^\circ\text{C} \\ &= 468 \text{ kJ/h} = 130 \text{ W} \quad (\text{since } 1 \text{ W} = 3.6 \text{ kJ/h}) \end{aligned}$$

Then total refrigeration load becomes

$$\dot{Q}_{\text{refrig, total}} = \dot{Q}_{\text{cooling}} + \dot{Q}_{\text{transfer}} = 130 + 45 = 175 \text{ W}$$

Noting that the coefficient of performance of the refrigeration system is 2.9, the required power input is

$$\dot{W}_{\text{refrig}} = \frac{\dot{Q}_{\text{refrig}}}{\text{COP}} = \frac{175 \text{ W}}{2.9} = \mathbf{60.3 \text{ W}}$$

Therefore, the power rating of the compressor of this refrigeration system must be at least 60.3 W to meet the cold water requirements of this office.

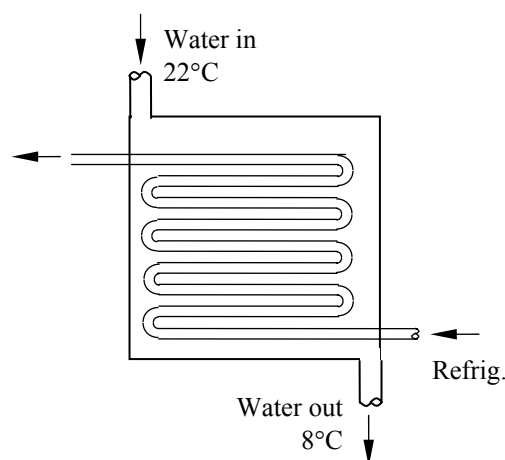

6-146E A washing machine uses \$33/year worth of hot water heated by a gas water heater. The amount of hot water an average family uses per week is to be determined.

Assumptions **1** The electricity consumed by the motor of the washer is negligible. **2** Water is an incompressible substance with constant properties at room temperature.

Properties The density and specific heat of water at room temperature are $\rho = 62.1 \text{ lbm/ft}^3$ and $c = 1.00 \text{ Btu/lbm}\cdot^\circ\text{F}$ (Table A-3E).

Analysis The amount of electricity used to heat the water and the net amount transferred to water are

$$\text{Total energy used (gas)} = \frac{\text{Total cost of energy}}{\text{Unit cost of energy}} = \frac{\$33/\text{year}}{\$1.21/\text{therm}} = 27.27 \text{ therms/year}$$

$$\begin{aligned} \text{Total energy transfer to water} &= \dot{E}_{\text{in}} = (\text{Efficiency})(\text{Total energy used}) = 0.58 \times 27.27 \text{ therms/year} \\ &= 15.82 \text{ therms/year} = (15.82 \text{ therms/year}) \left(\frac{100,000 \text{ Btu}}{1 \text{ therm}} \right) \left(\frac{1 \text{ year}}{52 \text{ weeks}} \right) \\ &= 30,420 \text{ Btu/week} \end{aligned}$$

Then the mass and the volume of hot water used per week become

$$\dot{E}_{\text{in}} = \dot{m}c(T_{\text{out}} - T_{\text{in}}) \rightarrow \dot{m} = \frac{\dot{E}_{\text{in}}}{c(T_{\text{out}} - T_{\text{in}})} = \frac{30,420 \text{ Btu/week}}{(1.0 \text{ Btu/lbm}\cdot^\circ\text{F})(130 - 60)^\circ\text{F}} = 434.6 \text{ lbm/week}$$

and

$$\dot{V}_{\text{water}} = \frac{\dot{m}}{\rho} = \frac{434.6 \text{ lbm/week}}{62.1 \text{ lbm/ft}^3} = (7.0 \text{ ft}^3 / \text{week}) \left(\frac{7.4804 \text{ gal}}{1 \text{ ft}^3} \right) = \mathbf{52.4 \text{ gal/week}}$$

Therefore, an average family uses about 52 gallons of hot water per week for washing clothes.

6-147  A typical heat pump powered water heater costs about \$800 more to install than a typical electric water heater. The number of years it will take for the heat pump water heater to pay for its cost differential from the energy it saves is to be determined.

Assumptions **1** The price of electricity remains constant. **2** Water is an incompressible substance with constant properties at room temperature. **3** Time value of money (interest, inflation) is not considered.

Analysis The amount of electricity used to heat the water and the net amount transferred to water are

$$\begin{aligned} \text{Total energy used (electrical)} &= \frac{\text{Total cost of energy}}{\text{Unit cost of energy}} \\ &= \frac{\$250/\text{year}}{\$0.080/\text{kWh}} \\ &= 3125 \text{ kWh/year} \end{aligned}$$

$$\begin{aligned} \text{Total energy transfer to water} &= \dot{E}_{\text{in}} = (\text{Efficiency})(\text{Total energy used}) = 0.95 \times 3125 \text{ kWh/year} \\ &= 2969 \text{ kWh/year} \end{aligned}$$

The amount of electricity consumed by the heat pump and its cost are

$$\text{Energy usage (of heat pump)} = \frac{\text{Energy transfer to water}}{\text{COP}_{\text{HP}}} = \frac{2969 \text{ kWh/year}}{3.3} = 899.6 \text{ kWh/year}$$

$$\begin{aligned} \text{Energy cost (of heat pump)} &= (\text{Energy usage})(\text{Unit cost of energy}) = (899.6 \text{ kWh/year})(\$0.08/\text{kWh}) \\ &= \$71.97/\text{year} \end{aligned}$$

Then the money saved per year by the heat pump and the simple payback period become

$$\begin{aligned} \text{Money saved} &= (\text{Energy cost of electric heater}) - (\text{Energy cost of heat pump}) \\ &= \$250 - \$71.97 = \$178.0 \end{aligned}$$

$$\text{Simple payback period} = \frac{\text{Additional installation cost}}{\text{Money saved}} = \frac{\$800}{\$178.0/\text{year}} = \mathbf{4.49 \text{ years}}$$

Discussion The economics of heat pump water heater will be even better if the air in the house is used as the heat source for the heat pump in summer, and thus also serving as an air-conditioner.

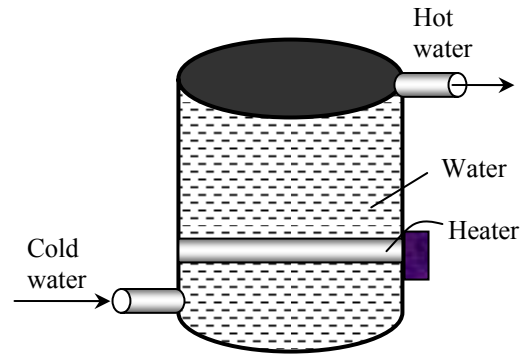



6-148 Problem 6-147 is reconsidered. The effect of the heat pump COP on the yearly operation costs and the number of years required to break even are to be considered.

Analysis The problem is solved using EES, and the results are tabulated and plotted below.

"Energy supplied by the water heater to the water per year is E_ElecHeater"

"Cost per year to operate electric water heater for one year is:"

Cost_ElectHeater = 250 [\$/year]

"Energy supplied to the water by electric heater is 90% of energy purchased"

eta=0.95

E_ElectHeater = eta*Cost_ElectHeater /UnitCost "[kWh/year]"

UnitCost=0.08 [\$/kWh]

"For the same amount of heated water and assuming that all the heat energy leaving the heat pump goes into the water, then"

"Energy supplied by heat pump heater = Energy supplied by electric heater"

E_HeatPump = E_ElectHeater "[kWh/year]"

"Electrical Work energy supplied to heat pump = Heat added to water/COP"

COP=3.3

W_HeatPump = E_HeatPump/COP "[kWh/year]"

"Cost per year to operate the heat pump is"

Cost_HeatPump=W_HeatPump*UnitCost

"Let N_BrkEven be the number of years to break even:"

"At the break even point, the total cost difference between the two water heaters is zero."

"Years to break even, neglecting the cost to borrow the extra \$800 to install heat pump"

CostDiff_total = 0 [\$]

CostDiff_total=AddCost+N_BrkEven*(Cost_HeatPump-Cost_ElectHeater) "[\$]"

AddCost=800 [\$]

| COP | B _{BrkEven} [years] | Cost _{HeatPump} [\$/year] | Cost _{ElektHeater} [\$/year] |
|-----|---------------------------------|---------------------------------------|--|
| 2 | 6.095 | 118.8 | 250 |
| 2.3 | 5.452 | 103.3 | 250 |
| 2.6 | 5.042 | 91.35 | 250 |
| 2.9 | 4.759 | 81.9 | 250 |
| 3.2 | 4.551 | 74.22 | 250 |
| 3.5 | 4.392 | 67.86 | 250 |
| 3.8 | 4.267 | 62.5 | 250 |
| 4.1 | 4.165 | 57.93 | 250 |
| 4.4 | 4.081 | 53.98 | 250 |
| 4.7 | 4.011 | 50.53 | 250 |
| 5 | 3.951 | 47.5 | 250 |

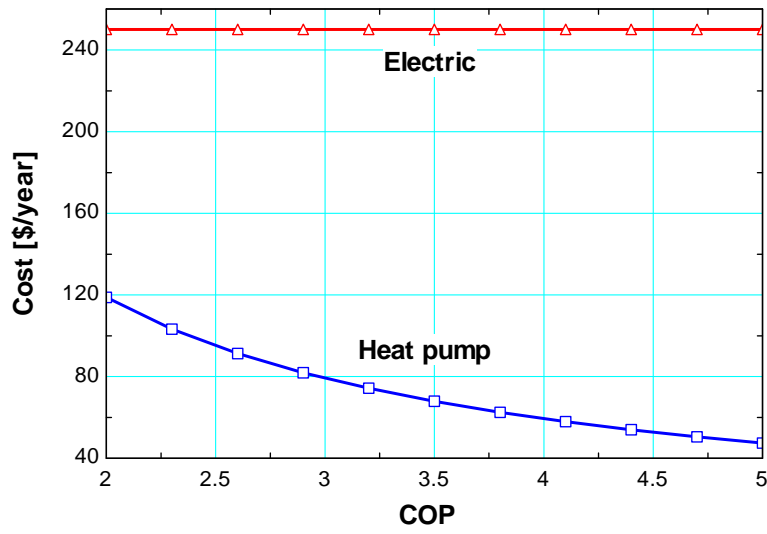
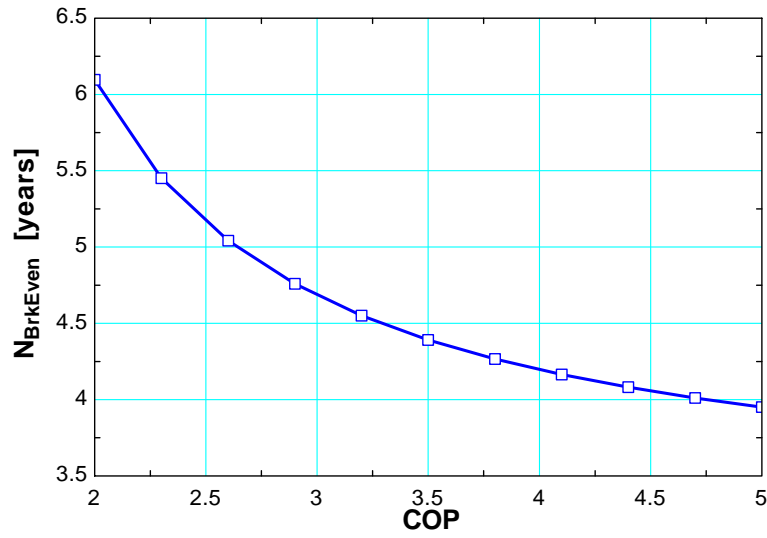

6-149 A home owner is to choose between a high-efficiency natural gas furnace and a ground-source heat pump. The system with the lower energy cost is to be determined.

Assumptions The two heater are comparable in all aspects other than the cost of energy.

Analysis The unit cost of each kJ of useful energy supplied to the house by each system is

$$\text{Natural gas furnace:} \quad \text{Unit cost of useful energy} = \frac{(\$1.42/\text{therm})}{0.97} \left(\frac{1 \text{ therm}}{105,500 \text{ kJ}} \right) = \$13.8 \times 10^{-6} / \text{kJ}$$

$$\text{Heat Pump System:} \quad \text{Unit cost of useful energy} = \frac{(\$0.092/\text{kWh})}{3.5} \left(\frac{1 \text{ kWh}}{3600 \text{ kJ}} \right) = \$7.3 \times 10^{-6} / \text{kJ}$$

The energy cost of **ground-source heat pump system** will be lower.

6-150 The ventilating fans of a house discharge a houseful of warmed air in one hour (ACH = 1). For an average outdoor temperature of 5°C during the heating season, the cost of energy “vented out” by the fans in 1 h is to be determined.

Assumptions 1 Steady operating conditions exist. **2** The house is maintained at 22°C and 92 kPa at all times. **3** The infiltrating air is heated to 22°C before it is vented out. **4** Air is an ideal gas with constant specific heats at room temperature. **5** The volume occupied by the people, furniture, etc. is negligible.

Properties The gas constant of air is $R = 0.287 \text{ kPa}\cdot\text{m}^3/\text{kg}\cdot\text{K}$ (Table A-1). The specific heat of air at room temperature is $c_p = 1.0 \text{ kJ}/\text{kg}\cdot^\circ\text{C}$ (Table A-2a).

Analysis The density of air at the indoor conditions of 92 kPa and 22°C is

$$\rho_o = \frac{P_o}{RT_o} = \frac{92 \text{ kPa}}{(0.287 \text{ kPa}\cdot\text{m}^3/\text{kg}\cdot\text{K})(22 + 273 \text{ K})} = 1.087 \text{ kg}/\text{m}^3$$

Noting that the interior volume of the house is $200 \times 2.8 = 560 \text{ m}^3$, the mass flow rate of air vented out becomes

$$\dot{m}_{\text{air}} = \rho \dot{V}_{\text{air}} = (1.087 \text{ kg}/\text{m}^3)(560 \text{ m}^3/\text{h}) = 608.7 \text{ kg}/\text{h} = 0.169 \text{ kg}/\text{s}$$

Noting that the indoor air vented out at 22°C is replaced by infiltrating outdoor air at 5°C, this corresponds to energy loss at a rate of

$$\begin{aligned} \dot{Q}_{\text{loss, fan}} &= \dot{m}_{\text{air}} c_p (T_{\text{indoors}} - T_{\text{outdoors}}) \\ &= (0.169 \text{ kg}/\text{s})(1.0 \text{ kJ}/\text{kg}\cdot^\circ\text{C})(22 - 5)^\circ\text{C} = 2.874 \text{ kJ}/\text{s} = 2.874 \text{ kW} \end{aligned}$$

Then the amount and cost of the heat “vented out” per hour becomes

$$\begin{aligned} \text{Fuel energy loss} &= \dot{Q}_{\text{loss, fan}} \Delta t / \eta_{\text{furnace}} = (2.874 \text{ kW})(1 \text{ h})/0.96 = 2.994 \text{ kWh} \\ \text{Money loss} &= (\text{Fuel energy loss})(\text{Unit cost of energy}) \\ &= (2.994 \text{ kWh})(\$1.20/\text{therm}) \left(\frac{1 \text{ therm}}{29.3 \text{ kWh}} \right) = \mathbf{\$0.123} \end{aligned}$$

Discussion Note that the energy and money loss associated with ventilating fans can be very significant. Therefore, ventilating fans should be used sparingly.

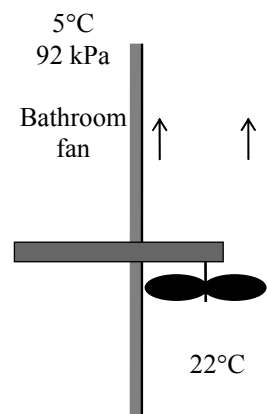

6-151 The ventilating fans of a house discharge a houseful of air-conditioned air in one hour ($ACH = 1$). For an average outdoor temperature of 28°C during the cooling season, the cost of energy “vented out” by the fans in 1 h is to be determined.

Assumptions **1** Steady operating conditions exist. **2** The house is maintained at 22°C and 92 kPa at all times. **3** The infiltrating air is cooled to 22°C before it is vented out. **4** Air is an ideal gas with constant specific heats at room temperature. **5** The volume occupied by the people, furniture, etc. is negligible. **6** Latent heat load is negligible.

Properties The gas constant of air is $R = 0.287 \text{ kPa}\cdot\text{m}^3/\text{kg}\cdot\text{K}$ (Table A-1). The specific heat of air at room temperature is $c_p = 1.0 \text{ kJ}/\text{kg}\cdot^\circ\text{C}$ (Table A-2a).

Analysis The density of air at the indoor conditions of 92 kPa and 22°C is

$$\rho_o = \frac{P_o}{RT_o} = \frac{92 \text{ kPa}}{(0.287 \text{ kPa}\cdot\text{m}^3/\text{kg}\cdot\text{K})(22 + 273 \text{ K})} = 1.087 \text{ kg}/\text{m}^3$$

Noting that the interior volume of the house is $200 \times 2.8 = 560 \text{ m}^3$, the mass flow rate of air vented out becomes

$$\dot{m}_{\text{air}} = \rho \dot{V}_{\text{air}} = (1.087 \text{ kg}/\text{m}^3)(560 \text{ m}^3/\text{h}) = 608.7 \text{ kg}/\text{h} = 0.169 \text{ kg}/\text{s}$$

Noting that the indoor air vented out at 22°C is replaced by infiltrating outdoor air at 28°C , this corresponds to energy loss at a rate of

$$\begin{aligned} \dot{Q}_{\text{loss, fan}} &= \dot{m}_{\text{air}} c_p (T_{\text{outdoors}} - T_{\text{indoors}}) \\ &= (0.169 \text{ kg}/\text{s})(1.0 \text{ kJ}/\text{kg}\cdot^\circ\text{C})(28 - 22)^\circ\text{C} = 1.014 \text{ kJ}/\text{s} = 1.014 \text{ kW} \end{aligned}$$

Then the amount and cost of the electric energy “vented out” per hour becomes

$$\text{Electric energy loss} = \dot{Q}_{\text{loss, fan}} \Delta t / COP = (1.014 \text{ kW})(1 \text{ h})/2.3 = 0.441 \text{ kWh}$$

$$\begin{aligned} \text{Money loss} &= (\text{Fuel energy loss})(\text{Unit cost of energy}) \\ &= (0.441 \text{ kWh})(\$0.10/\text{kWh}) = \mathbf{\$0.044} \end{aligned}$$

Discussion Note that the energy and money loss associated with ventilating fans can be very significant. Therefore, ventilating fans should be used sparingly.

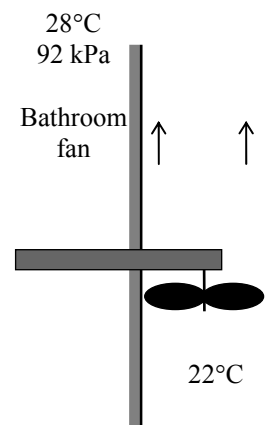

6-152 A geothermal heat pump with R-134a as the working fluid is considered. The evaporator inlet and exit states are specified. The mass flow rate of the refrigerant, the heating load, the COP, and the minimum power input to the compressor are to be determined.

Assumptions 1 The heat pump operates steadily. **2** The kinetic and potential energy changes are zero. **3** Steam properties are used for geothermal water.

Properties The properties of R-134a and water are (Steam and R-134a tables)

$$\left. \begin{array}{l} T_1 = 12^\circ\text{C} \\ x_1 = 0.15 \end{array} \right\} \begin{array}{l} h_1 = 96.55 \text{ kJ/kg} \\ P_1 = 443.3 \text{ kPa} \end{array}$$

$$\left. \begin{array}{l} P_2 = P_1 = 443.3 \text{ kPa} \\ x_2 = 1 \end{array} \right\} h_2 = 257.27 \text{ kJ/kg}$$

$$\left. \begin{array}{l} T_{w,1} = 60^\circ\text{C} \\ x_{w,1} = 0 \end{array} \right\} h_{w,1} = 251.18 \text{ kJ/kg}$$

$$\left. \begin{array}{l} T_{w,2} = 40^\circ\text{C} \\ x_{w,2} = 0 \end{array} \right\} h_{w,2} = 167.53 \text{ kJ/kg}$$

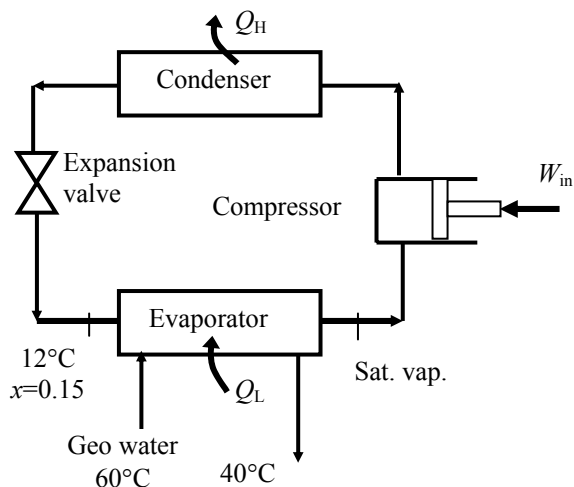

Analysis (a) The rate of heat transferred from the water is the energy change of the water from inlet to exit

$$\dot{Q}_L = \dot{m}_w (h_{w,1} - h_{w,2}) = (0.065 \text{ kg/s})(251.18 - 167.53) \text{ kJ/kg} = 5.437 \text{ kW}$$

The energy increase of the refrigerant is equal to the energy decrease of the water in the evaporator. That is,

$$\dot{Q}_L = \dot{m}_R (h_2 - h_1) \longrightarrow \dot{m}_R = \frac{\dot{Q}_L}{h_2 - h_1} = \frac{5.437 \text{ kW}}{(257.27 - 96.55) \text{ kJ/kg}} = \mathbf{0.0338 \text{ kg/s}}$$

(b) The heating load is

$$\dot{Q}_H = \dot{Q}_L + \dot{W}_{\text{in}} = 5.437 + 1.6 = \mathbf{7.04 \text{ kW}}$$

(c) The COP of the heat pump is determined from its definition,

$$\text{COP} = \frac{\dot{Q}_H}{\dot{W}_{\text{in}}} = \frac{7.04 \text{ kW}}{1.6 \text{ kW}} = \mathbf{4.40}$$

(d) The COP of a reversible heat pump operating between the same temperature limits is

$$\text{COP}_{\text{max}} = \frac{1}{1 - T_L / T_H} = \frac{1}{1 - (25 + 273) / (60 + 273)} = 9.51$$

Then, the minimum power input to the compressor for the same refrigeration load would be

$$\dot{W}_{\text{in,min}} = \frac{\dot{Q}_H}{\text{COP}_{\text{max}}} = \frac{7.04 \text{ kW}}{9.51} = \mathbf{0.740 \text{ kW}}$$

6-153 A heat pump is used as the heat source for a water heater. The rate of heat supplied to the water and the minimum power supplied to the heat pump are to be determined.

Assumptions 1 Steady operating conditions exist. 2 The kinetic and potential energy changes are zero.

Properties The specific heat and specific volume of water at room temperature are $c_p = 4.18 \text{ kJ/kg}\cdot\text{K}$ and $\nu = 0.001 \text{ m}^3/\text{kg}$ (Table A-3).

Analysis (a) An energy balance on the water heater gives the rate of heat supplied to the water

$$\begin{aligned}\dot{Q}_H &= \dot{m}c_p(T_2 - T_1) \\ &= \frac{\dot{V}}{\nu}c_p(T_2 - T_1) \\ &= \frac{(0.02/60) \text{ m}^3/\text{s}}{0.001 \text{ m}^3/\text{kg}}(4.18 \text{ kJ/kg}\cdot\text{C})(50 - 10) \text{ C} \\ &= \mathbf{55.73 \text{ kW}}\end{aligned}$$

(b) The COP of a reversible heat pump operating between the specified temperature limits is

$$\text{COP}_{\max} = \frac{1}{1 - T_L/T_H} = \frac{1}{1 - (0 + 273)/(30 + 273)} = 10.1$$

Then, the minimum power input would be

$$\dot{W}_{\text{in},\text{min}} = \frac{\dot{Q}_H}{\text{COP}_{\max}} = \frac{55.73 \text{ kW}}{10.1} = \mathbf{5.52 \text{ kW}}$$

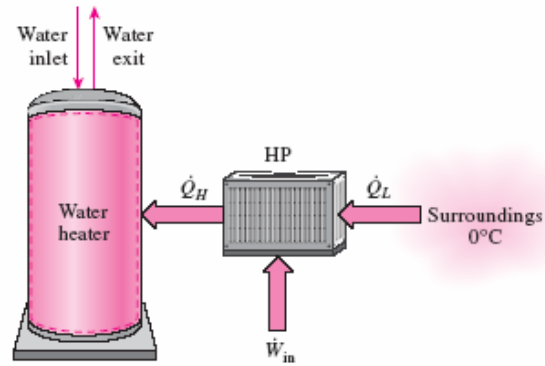

6-154 A heat pump receiving heat from a lake is used to heat a house. The minimum power supplied to the heat pump and the mass flow rate of lake water are to be determined.

Assumptions 1 Steady operating conditions exist. 2 The kinetic and potential energy changes are zero.

Properties The specific heat of water at room temperature is $c_p = 4.18 \text{ kJ/kg}\cdot\text{K}$ (Table A-3).

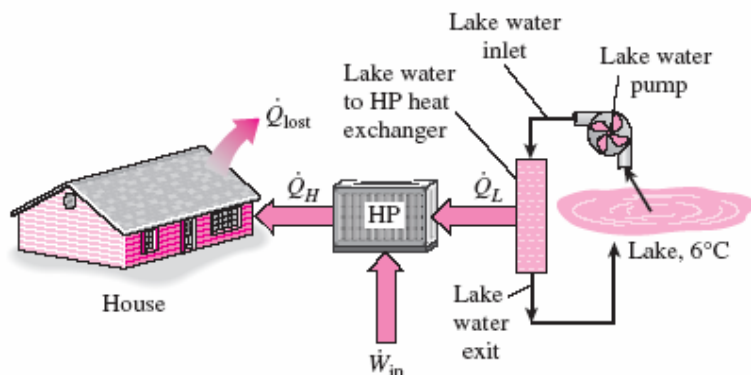

Analysis (a) The COP of a reversible heat pump operating between the specified temperature limits is

$$\text{COP}_{\max} = \frac{1}{1 - T_L / T_H} = \frac{1}{1 - (6 + 273) / (27 + 273)} = 14.29$$

Then, the minimum power input would be

$$\dot{W}_{\text{in, min}} = \frac{\dot{Q}_H}{\text{COP}_{\max}} = \frac{(64,000 / 3600) \text{ kW}}{14.29} = \mathbf{1.244 \text{ kW}}$$

(b) The rate of heat absorbed from the lake is

$$\dot{Q}_L = \dot{Q}_H - \dot{W}_{\text{in, min}} = 17.78 - 1.244 = 16.53 \text{ kW}$$

An energy balance on the heat exchanger gives the mass flow rate of lake water

$$\dot{m}_{\text{water}} = \frac{\dot{Q}_L}{c_p \Delta T} = \frac{16.53 \text{ kJ/s}}{(4.18 \text{ kJ/kg}\cdot\text{°C})(5 \text{ °C})} = \mathbf{0.791 \text{ kg/s}}$$

6-155 It is to be proven that a refrigerator's COP cannot exceed that of a completely reversible refrigerator that shares the same thermal-energy reservoirs.

Assumptions The refrigerator operates steadily.

Analysis We begin by assuming that the COP of the general refrigerator B is greater than that of the completely reversible refrigerator A , $\text{COP}_B > \text{COP}_A$. When this is the case, a rearrangement of the coefficient of performance expression yields

$$W_B = \frac{Q_L}{\text{COP}_B} < \frac{Q_L}{\text{COP}_A} = W_A$$

That is, the magnitude of the work required to drive refrigerator B is less than that needed to drive completely reversible refrigerator A . Applying the first law to both refrigerators yields

$$Q_{H,B} < Q_{H,A}$$

since the work supplied to refrigerator B is less than that supplied to refrigerator A , and both have the same cooling effect, Q_L .

Since A is a completely reversible refrigerator, we can reverse it without changing the magnitude of the heat and work transfers. This is illustrated in the figure below. The heat, Q_L , which is rejected by the reversed refrigerator A can now be routed directly to refrigerator B . The net effect when this is done is that no heat is exchanged with the T_L reservoir. The magnitude of the heat supplied to the reversed refrigerator A , $Q_{H,A}$ has been shown to be larger than that rejected by refrigerator B . There is then a net heat transfer from the T_H reservoir to the combined device in the dashed lines of the figure whose magnitude is given by $Q_{H,A} - Q_{H,B}$. Similarly, there is a net work production by the combined device whose magnitude is given by $W_A - W_B$.

The combined cyclic device then exchanges heat with a reservoir at a single temperature and produces work which is clearly a violation of the Kelvin-Planck statement of the second law. Our assumption the $\text{COP}_B > \text{COP}_A$ must then be wrong.

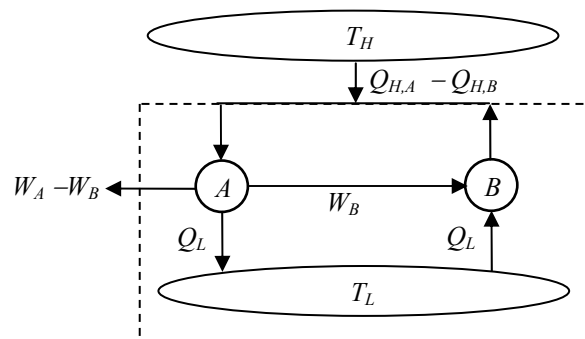
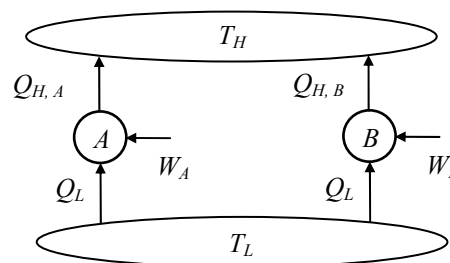

6-156 It is to be proven that the COP of all completely reversible refrigerators must be the same when the reservoir temperatures are the same.

Assumptions The refrigerators operate steadily.

Analysis We begin by assuming that $\text{COP}_A < \text{COP}_B$. When this is the case, a rearrangement of the coefficient of performance expression yields

$$W_A = \frac{Q_L}{\text{COP}_A} > \frac{Q_L}{\text{COP}_B} = W_B$$

That is, the magnitude of the work required to drive refrigerator *A* is greater than that needed to drive refrigerator *B*. Applying the first law to both refrigerators yields

$$Q_{H,A} > Q_{H,B}$$

since the work supplied to refrigerator *A* is greater than that supplied to refrigerator *B*, and both have the same cooling effect, Q_L .

Since *A* is a completely reversible refrigerator, we can reverse it without changing the magnitude of the heat and work transfers. This is illustrated in the figure below. The heat, Q_L , which is rejected by the reversed refrigerator *A* can now be routed directly to refrigerator *B*. The net effect when this is done is that no heat is exchanged with the T_L reservoir. The magnitude of the heat supplied to the reversed refrigerator *A*, $Q_{H,A}$ has been shown to be larger than that rejected by refrigerator *B*. There is then a net heat transfer from the T_H reservoir to the combined device in the dashed lines of the figure whose magnitude is given by $Q_{H,A} - Q_{H,B}$. Similarly, there is a net work production by the combined device whose magnitude is given by $W_A - W_B$.

The combined cyclic device then exchanges heat with a reservoir at a single temperature and produces work which is clearly a violation of the Kelvin-Planck statement of the second law. Our assumption the $\text{COP}_A < \text{COP}_B$ must then be wrong.

If we interchange *A* and *B* in the previous argument, we would conclude that the COP_B cannot be less than COP_A . The only alternative left is that

$$\text{COP}_A = \text{COP}_B$$

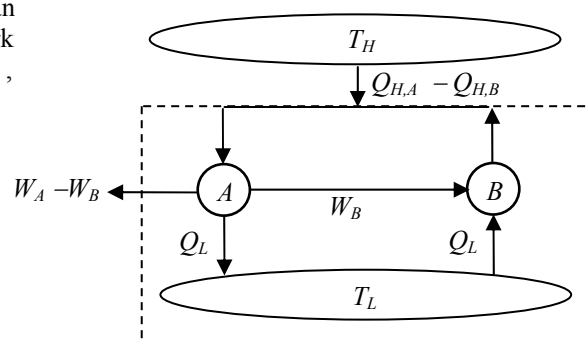
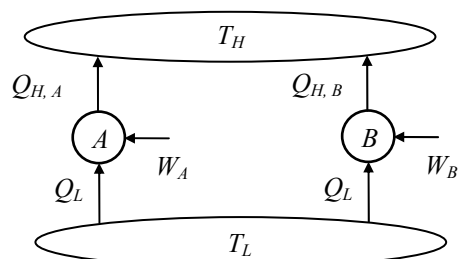

6-157 An expression for the COP of a completely reversible heat pump in terms of the thermal-energy reservoir temperatures, T_L and T_H is to be derived.

Assumptions The heat pump operates steadily.

Analysis Application of the first law to the completely reversible heat pump yields

$$W_{\text{net,in}} = Q_H - Q_L$$

This result may be used to reduce the coefficient of performance,

$$\text{COP}_{\text{HP,rev}} = \frac{Q_H}{W_{\text{net,in}}} = \frac{Q_H}{Q_H - Q_L} = \frac{1}{1 - Q_L/Q_H}$$

Since this heat pump is completely reversible, the thermodynamic definition of temperature tells us that,

$$\frac{Q_L}{Q_H} = \frac{T_L}{T_H}$$

When this is substituted into the COP expression, the result is

$$\text{COP}_{\text{HP,rev}} = \frac{1}{1 - T_L/T_H} = \frac{T_H}{T_H - T_L}$$

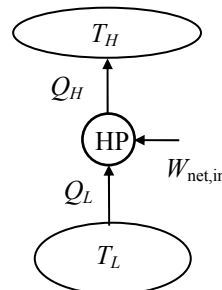

6-158 A Carnot heat engine is operating between specified temperature limits. The source temperature that will double the efficiency is to be determined.

Analysis Denoting the new source temperature by T_H^* , the thermal efficiency of the Carnot heat engine for both cases can be expressed as

$$\eta_{\text{th,C}} = 1 - \frac{T_L}{T_H} \quad \text{and} \quad \eta_{\text{th,C}}^* = 1 - \frac{T_L}{T_H^*} = 2\eta_{\text{th,C}}$$

Substituting,

$$1 - \frac{T_L}{T_H^*} = 2 \left(1 - \frac{T_L}{T_H} \right)$$

Solving for T_H^* ,

$$T_H^* = \frac{T_H T_L}{T_H - 2T_L}$$

which is the desired relation.

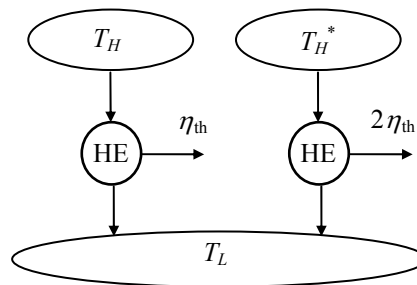

6-159 A Carnot cycle is analyzed for the case of temperature differences in the boiler and condenser. The ratio of overall temperatures for which the power output will be maximum, and an expression for the maximum net power output are to be determined.

Analysis It is given that

$$\dot{Q}_H = (hA)_H (T_H - T_H^*)$$

Therefore,

$$\dot{W} = \eta_{th} \dot{Q}_H = \left(1 - \frac{T_L^*}{T_H^*}\right) (hA)_H (T_H - T_H^*) = \left(1 - \frac{T_L^*}{T_H^*}\right) (hA)_H \left(1 - \frac{T_H^*}{T_H}\right) T_H$$

or,

$$\frac{\dot{W}}{(hA)_H T_H} = \left(1 - \frac{T_L^*}{T_H^*}\right) \left(1 - \frac{T_H^*}{T_H}\right) = (1-r)x \quad (1)$$

where we defined r and x as $r = T_L^*/T_H^*$ and $x = 1 - T_H^*/T_H$.

For a reversible cycle we also have

$$\frac{T_H^*}{T_L^*} = \frac{\dot{Q}_H}{\dot{Q}_L} \longrightarrow \frac{1}{r} = \frac{(hA)_H (T_H - T_H^*)}{(hA)_L (T_L^* - T_L)} = \frac{(hA)_H T_H (1 - T_H^*/T_H)}{(hA)_L T_H (T_L^*/T_H - T_L/T_H)}$$

but

$$\frac{T_L^*}{T_H} = \frac{T_L^*}{T_H^*} \frac{T_H^*}{T_H} = r(1-x)$$

Substituting into above relation yields

$$\frac{1}{r} = \frac{(hA)_H x}{(hA)_L [r(1-x) - T_L/T_H]}$$

Solving for x ,

$$x = \frac{r - T_L/T_H}{r[(hA)_H/(hA)_L + 1]} \quad (2)$$

Substitute (2) into (1):

$$\dot{W} = (hA)_H T_H (1-r) \frac{r - T_L/T_H}{r[(hA)_H/(hA)_L + 1]} \quad (3)$$

Taking the partial derivative $\frac{\partial \dot{W}}{\partial r}$ holding everything else constant and setting it equal to zero gives

$$r = \frac{T_L^*}{T_H} = \left(\frac{T_L}{T_H}\right)^{1/2} \quad (4)$$

which is the desired relation. The maximum net power output in this case is determined by substituting (4) into (3). It simplifies to

$$\dot{W}_{\max} = \frac{(hA)_H T_H}{1 + (hA)_H/(hA)_L} \left\{1 - \left(\frac{T_L}{T_H}\right)^{1/2}\right\}^2$$

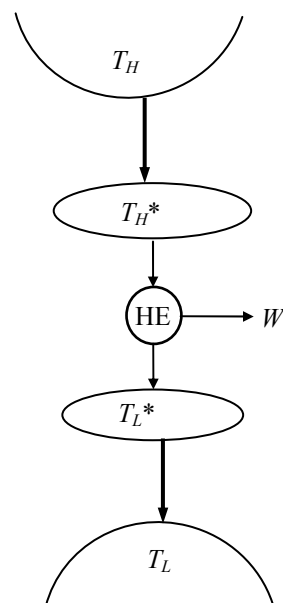

Fundamentals of Engineering (FE) Exam Problems

6-160 The label on a washing machine indicates that the washer will use \$85 worth of hot water if the water is heated by a 90% efficiency electric heater at an electricity rate of \$0.09/kWh. If the water is heated from 18°C to 45°C, the amount of hot water an average family uses per year, in metric tons, is

- (a) 11.6 tons (b) 15.8 tons (c) 27.1 tons (d) 30.1 tons (e) 33.5 tons

Answer (b) 27.1 tons

Solution Solved by EES Software. Solutions can be verified by copying-and-pasting the following lines on a blank EES screen. (Similar problems and their solutions can be obtained easily by modifying numerical values).

```
Eff=0.90
C=4.18 "kJ/kg-C"
T1=18 "C"
T2=45 "C"
Cost=85 "$"
Price=0.09 "$/kWh"
Ein=(Cost/Price)*3600 "kJ"
Ein=m*C*(T2-T1)/Eff "kJ"
```

"Some Wrong Solutions with Common Mistakes:"

```
Ein=W1_m*C*(T2-T1)*Eff "Multiplying by Eff instead of dividing"
Ein=W2_m*C*(T2-T1) "Ignoring efficiency"
Ein=W3_m*(T2-T1)/Eff "Not using specific heat"
Ein=W4_m*C*(T2+T1)/Eff "Adding temperatures"
```

6-161 A 2.4-m high 200-m² house is maintained at 22°C by an air-conditioning system whose COP is 3.2. It is estimated that the kitchen, bath, and other ventilating fans of the house discharge a houseful of conditioned air once every hour. If the average outdoor temperature is 32°C, the density of air is 1.20 kg/m³, and the unit cost of electricity is \$0.10/kWh, the amount of money “vented out” by the fans in 10 hours is

- (a) \$0.50 (b) \$1.60 (c) \$5.00 (d) \$11.00 (e) \$16.00

Answer (a) \$0.50

Solution Solved by EES Software. Solutions can be verified by copying-and-pasting the following lines on a blank EES screen. (Similar problems and their solutions can be obtained easily by modifying numerical values).

```
COP=3.2
T1=22 "C"
T2=32 "C"
Price=0.10 "$/kWh"
Cp=1.005 "kJ/kg-C"
rho=1.20 "kg/m^3"
V=2.4*200 "m^3"
m=rho*V
m_total=m*10
Ein=m_total*Cp*(T2-T1)/COP "kJ"
Cost=(Ein/3600)*Price
```

"Some Wrong Solutions with Common Mistakes:"

W1_Cost=(Price/3600)*m_total*Cp*(T2-T1)*COP "Multiplying by Eff instead of dividing"

W2_Cost=(Price/3600)*m_total*Cp*(T2-T1) "Ignoring efficiency"

W3_Cost=(Price/3600)*m*Cp*(T2-T1)/COP "Using m instead of m_total"

W4_Cost=(Price/3600)*m_total*Cp*(T2+T1)/COP "Adding temperatures"

6-162 The drinking water needs of an office are met by cooling tap water in a refrigerated water fountain from 23°C to 6°C at an average rate of 10 kg/h. If the COP of this refrigerator is 3.1, the required power input to this refrigerator is

- (a) 197 W (b) 612 W (c) 64 W (d) 109 W (e) 403 W

Answer (c) 64 W

Solution Solved by EES Software. Solutions can be verified by copying-and-pasting the following lines on a blank EES screen. (Similar problems and their solutions can be obtained easily by modifying numerical values).

```
COP=3.1
Cp=4.18 "kJ/kg-C"
T1=23 "C"
T2=6 "C"
m_dot=10/3600 "kg/s"
Q_L=m_dot*Cp*(T1-T2) "kW"
W_in=Q_L*1000/COP "W"
```

"Some Wrong Solutions with Common Mistakes:"

W1_Win=m_dot*Cp*(T1-T2) *1000*COP "Multiplying by COP instead of dividing"

W2_Win=m_dot*Cp*(T1-T2) *1000 "Not using COP"

W3_Win=m_dot*(T1-T2) *1000/COP "Not using specific heat"

W4_Win=m_dot*Cp*(T1+T2) *1000/COP "Adding temperatures"

6-163 A heat pump is absorbing heat from the cold outdoors at 5°C and supplying heat to a house at 25°C at a rate of 18,000 kJ/h. If the power consumed by the heat pump is 1.9 kW, the coefficient of performance of the heat pump is

- (a) 1.3 (b) 2.6 (c) 3.0 (d) 3.8 (e) 13.9

Answer (b) 2.6

Solution Solved by EES Software. Solutions can be verified by copying-and-pasting the following lines on a blank EES screen. (Similar problems and their solutions can be obtained easily by modifying numerical values).

```
TL=5 "C"
TH=25 "C"
QH=18000/3600 "kJ/s"
Win=1.9 "kW"
COP=QH/Win
```

"Some Wrong Solutions with Common Mistakes:"

```
W1_COP=Win/QH "Doing it backwards"
W2_COP=TH/(TH-TL) "Using temperatures in C"
W3_COP=(TH+273)/(TH-TL) "Using temperatures in K"
W4_COP=(TL+273)/(TH-TL) "Finding COP of refrigerator using temperatures in K"
```

6-164 A heat engine cycle is executed with steam in the saturation dome. The pressure of steam is 1 MPa during heat addition, and 0.4 MPa during heat rejection. The highest possible efficiency of this heat engine is

- (a) 8.0% (b) 15.6% (c) 20.2% (d) 79.8% (e) 100%

Answer (a) 8.0%

Solution Solved by EES Software. Solutions can be verified by copying-and-pasting the following lines on a blank EES screen. (Similar problems and their solutions can be obtained easily by modifying numerical values).

```
PH=1000 "kPa"
PL=400 "kPa"
TH=TEMPERATURE(Steam_IAPWS,x=0,P=PH)
TL=TEMPERATURE(Steam_IAPWS,x=0,P=PL)
Eta_Carnot=1-(TL+273)/(TH+273)
```

"Some Wrong Solutions with Common Mistakes:"

```
W1_Eta_Carnot=1-PL/PH "Using pressures"
W2_Eta_Carnot=1-TL/TH "Using temperatures in C"
W3_Eta_Carnot=TL/TH "Using temperatures ratio"
```

6-165 A heat engine receives heat from a source at 1000°C and rejects the waste heat to a sink at 50°C. If heat is supplied to this engine at a rate of 100 kJ/s, the maximum power this heat engine can produce is

- (a) 25.4 kW (b) 55.4 kW (c) 74.6 kW (d) 95.0 kW (e) 100.0 kW

Answer (c) 74.6 kW

Solution Solved by EES Software. Solutions can be verified by copying-and-pasting the following lines on a blank EES screen. (Similar problems and their solutions can be obtained easily by modifying numerical values).

```
TH=1000 "C"
TL=50 "C"
Q_in=100 "kW"
Eta=1-(TL+273)/(TH+273)
W_out=Eta*Q_in
```

"Some Wrong Solutions with Common Mistakes:"

```
W1_W_out=(1-TL/TH)*Q_in "Using temperatures in C"
W2_W_out=Q_in "Setting work equal to heat input"
W3_W_out=Q_in/Eta "Dividing by efficiency instead of multiplying"
W4_W_out=(TL+273)/(TH+273)*Q_in "Using temperature ratio"
```

6-166 A heat pump cycle is executed with R-134a under the saturation dome between the pressure limits of 1.4 MPa and 0.16 MPa. The maximum coefficient of performance of this heat pump is

- (a) 1.1 (b) 3.8 (c) 4.8 (d) 5.3 (e) 2.9

Answer (c) 4.8

Solution Solved by EES Software. Solutions can be verified by copying-and-pasting the following lines on a blank EES screen. (Similar problems and their solutions can be obtained easily by modifying numerical values).

```
PH=1400 "kPa"
PL=160 "kPa"
TH=TEMPERATURE(R134a,x=0,P=PH) "C"
TL=TEMPERATURE(R134a,x=0,P=PL) "C"
COP_HP=(TH+273)/(TH-TL)
```

"Some Wrong Solutions with Common Mistakes:"

```
W1_COP=PH/(PH-PL) "Using pressures"
W2_COP=TH/(TH-TL) "Using temperatures in C"
W3_COP=TL/(TH-TL) "Refrigeration COP using temperatures in C"
W4_COP=(TL+273)/(TH-TL) "Refrigeration COP using temperatures in K"
```

6-167 A refrigeration cycle is executed with R-134a under the saturation dome between the pressure limits of 1.6 MPa and 0.2 MPa. If the power consumption of the refrigerator is 3 kW, the maximum rate of heat removal from the cooled space of this refrigerator is

- (a) 0.45 kJ/s (b) 0.78 kJ/s (c) 3.0 kJ/s (d) 11.6 kJ/s (e) 14.6 kJ/s

Answer (d) 11.6 kJ/s

Solution Solved by EES Software. Solutions can be verified by copying-and-pasting the following lines on a blank EES screen. (Similar problems and their solutions can be obtained easily by modifying numerical values).

```
PH=1600 "kPa"
PL=200 "kPa"
W_in=3 "kW"
TH=TEMPERATURE(R134a,x=0,P=PH) "C"
TL=TEMPERATURE(R134a,x=0,P=PL) "C"
COP=(TL+273)/(TH-TL)
QL=W_in*COP "kW"
```

"Some Wrong Solutions with Common Mistakes:"

```
W1_QL=W_in*TL/(TH-TL) "Using temperatures in C"
W2_QL=W_in "Setting heat removal equal to power input"
W3_QL=W_in/COP "Dividing by COP instead of multiplying"
W4_QL=W_in*(TH+273)/(TH-TL) "Using COP definition for Heat pump"
```

6-168 A heat pump with a COP of 3.2 is used to heat a perfectly sealed house (no air leaks). The entire mass within the house (air, furniture, etc.) is equivalent to 1200 kg of air. When running, the heat pump consumes electric power at a rate of 5 kW. The temperature of the house was 7°C when the heat pump was turned on. If heat transfer through the envelope of the house (walls, roof, etc.) is negligible, the length of time the heat pump must run to raise the temperature of the entire contents of the house to 22°C is

- (a) 13.5 min (b) 43.1 min (c) 138 min (d) 18.8 min (e) 808 min

Answer (a) 13.5 min

Solution Solved by EES Software. Solutions can be verified by copying-and-pasting the following lines on a blank EES screen. (Similar problems and their solutions can be obtained easily by modifying numerical values).

```
COP=3.2
Cv=0.718 "kJ/kg.C"
m=1200 "kg"
T1=7 "C"
T2=22 "C"
QH=m*Cv*(T2-T1)
Win=5 "kW"
Win*time=QH/COP/60
```

"Some Wrong Solutions with Common Mistakes:"

```
Win*W1_time*60=m*Cv*(T2-T1) *COP "Multiplying by COP instead of dividing"
Win*W2_time*60=m*Cv*(T2-T1) "Ignoring COP"
Win*W3_time=m*Cv*(T2-T1) /COP "Finding time in seconds instead of minutes"
Win*W4_time*60=m*Cp*(T2-T1) /COP "Using Cp instead of Cv"
Cp=1.005 "kJ/kg.K"
```

6-169 A heat engine cycle is executed with steam in the saturation dome between the pressure limits of 7 MPa and 2 MPa. If heat is supplied to the heat engine at a rate of 150 kJ/s, the maximum power output of this heat engine is

- (a) 8.1 kW (b) 19.7 kW (c) 38.6 kW (d) 107 kW (e) 130 kW

Answer (b) 19.7 kW

Solution Solved by EES Software. Solutions can be verified by copying-and-pasting the following lines on a blank EES screen. (Similar problems and their solutions can be obtained easily by modifying numerical values).

```
PH=7000 "kPa"
PL=2000 "kPa"
Q_in=150 "kW"
TH=TEMPERATURE(Steam_IAPWS,x=0,P=PH) "C"
TL=TEMPERATURE(Steam_IAPWS,x=0,P=PL) "C"
Eta=1-(TL+273)/(TH+273)
W_out=Eta*Q_in
```

"Some Wrong Solutions with Common Mistakes:"

```
W1_W_out=(1-TL/TH)*Q_in "Using temperatures in C"
W2_W_out=(1-PL/PH)*Q_in "Using pressures"
W3_W_out=Q_in/Eta "Dividing by efficiency instead of multiplying"
W4_W_out=(TL+273)/(TH+273)*Q_in "Using temperature ratio"
```

6-170 An air-conditioning system operating on the reversed Carnot cycle is required to remove heat from the house at a rate of 32 kJ/s to maintain its temperature constant at 20°C. If the temperature of the outdoors is 35°C, the power required to operate this air-conditioning system is

- (a) 0.58 kW (b) 3.20 kW (c) 1.56 kW (d) 2.26 kW (e) 1.64 kW

Answer (e) 1.64 kW

Solution Solved by EES Software. Solutions can be verified by copying-and-pasting the following lines on a blank EES screen. (Similar problems and their solutions can be obtained easily by modifying numerical values).

```
TL=20 "C"
TH=35 "C"
QL=32 "kJ/s"
COP=(TL+273)/(TH-TL)
COP=QL/W_in
```

"Some Wrong Solutions with Common Mistakes:"

```
QL=W1_W_in*TL/(TH-TL) "Using temperatures in C"
QL=W2_W_in "Setting work equal to heat input"
QL=W3_W_in/COP "Dividing by COP instead of multiplying"
QL=W4_W_in*(TH+273)/(TH-TL) "Using COP of HP"
```

6-171 A refrigerator is removing heat from a cold medium at 3°C at a rate of 7200 kJ/h and rejecting the waste heat to a medium at 30°C. If the coefficient of performance of the refrigerator is 2, the power consumed by the refrigerator is

- (a) 0.1 kW (b) 0.5 kW (c) 1.0 kW (d) 2.0 kW (e) 5.0 kW

Answer (c) 1.0 kW

Solution Solved by EES Software. Solutions can be verified by copying-and-pasting the following lines on a blank EES screen. (Similar problems and their solutions can be obtained easily by modifying numerical values).

```
TL=3 "C"
TH=30 "C"
QL=7200/3600 "kJ/s"
COP=2
QL=Win*COP
```

"Some Wrong Solutions with Common Mistakes:"

```
QL=W1_Win*(TL+273)/(TH-TL) "Using Carnot COP"
QL=W2_Win "Setting work equal to heat input"
QL=W3_Win/COP "Dividing by COP instead of multiplying"
QL=W4_Win*TL/(TH-TL) "Using Carnot COP using C"
```

6-172 Two Carnot heat engines are operating in series such that the heat sink of the first engine serves as the heat source of the second one. If the source temperature of the first engine is 1300 K and the sink temperature of the second engine is 300 K and the thermal efficiencies of both engines are the same, the temperature of the intermediate reservoir is

- (a) 625 K (b) 800 K (c) 860 K (d) 453 K (e) 758 K

Answer (a) 625 K

Solution Solved by EES Software. Solutions can be verified by copying-and-pasting the following lines on a blank EES screen. (Similar problems and their solutions can be obtained easily by modifying numerical values).

```
TH=1300 "K"
TL=300 "K"
"Setting thermal efficiencies equal to each other:"
1-Tmid/TH=1-TL/Tmid
```

"Some Wrong Solutions with Common Mistakes:"

```
W1_Tmid=(TL+TH)/2 "Using average temperature"
```

6-173 Consider a Carnot refrigerator and a Carnot heat pump operating between the same two thermal energy reservoirs. If the COP of the refrigerator is 3.4, the COP of the heat pump is

- (a) 1.7 (b) 2.4 (c) 3.4 (d) 4.4 (e) 5.0

Answer (d) 4.4

Solution Solved by EES Software. Solutions can be verified by copying-and-pasting the following lines on a blank EES screen. (Similar problems and their solutions can be obtained easily by modifying numerical values).

```
COP_R=3.4
COP_HP=COP_R+1
```

"Some Wrong Solutions with Common Mistakes:"

W1_COP=COP_R-1 "Subtracting 1 instead of adding 1"

W2_COP=COP_R "Setting COPs equal to each other"

6-174 A typical new household refrigerator consumes about 680 kWh of electricity per year, and has a coefficient of performance of 1.4. The amount of heat removed by this refrigerator from the refrigerated space per year is

- (a) 952 MJ/yr (b) 1749 MJ/yr (c) 2448 MJ/yr (d) 3427 MJ/yr (e) 4048 MJ/yr

Answer (d) 3427 MJ/yr

Solution Solved by EES Software. Solutions can be verified by copying-and-pasting the following lines on a blank EES screen. (Similar problems and their solutions can be obtained easily by modifying numerical values).

```
W_in=680*3.6 "MJ"
COP_R=1.4
QL=W_in*COP_R "MJ"
```

"Some Wrong Solutions with Common Mistakes:"

W1_QL=W_in*COP_R/3.6 "Not using the conversion factor"

W2_QL=W_in "Ignoring COP"

W3_QL=W_in/COP_R "Dividing by COP instead of multiplying"

6-175 A window air conditioner that consumes 1 kW of electricity when running and has a coefficient of performance of 3 is placed in the middle of a room, and is plugged in. The rate of cooling or heating this air conditioner will provide to the air in the room when running is

- (a) 3 kJ/s, cooling (b) 1 kJ/s, cooling (c) 0.33 kJ/s, heating (d) 1 kJ/s, heating (e) 3 kJ/s, heating

Answer (d) 1 kJ/s, heating

Solution Solved by EES Software. Solutions can be verified by copying-and-pasting the following lines on a blank EES screen. (Similar problems and their solutions can be obtained easily by modifying numerical values).

```
W_in=1 "kW"
```

```
COP=3
```

```
"From energy balance, heat supplied to the room is equal to electricity consumed,"
```

```
E_supplied=W_in "kJ/s, heating"
```

```
"Some Wrong Solutions with Common Mistakes:"
```

```
W1_E=-W_in "kJ/s, cooling"
```

```
W2_E=-COP*W_in "kJ/s, cooling"
```

```
W3_E=W_in/COP "kJ/s, heating"
```

```
W4_E=COP*W_in "kJ/s, heating"
```

6-176 ... 6-182 Design and Essay Problems

