

Chapter 9

GAS POWER CYCLES

Actual and Ideal Cycles, Carnot cycle, Air-Standard Assumptions

9-1C The Carnot cycle is not suitable as an ideal cycle for all power producing devices because it cannot be approximated using the hardware of actual power producing devices.

9-2C It is less than the thermal efficiency of a Carnot cycle.

9-3C It represents the net work on both diagrams.

9-4C The cold air standard assumptions involves the additional assumption that air can be treated as an ideal gas with constant specific heats at room temperature.

9-5C Under the air standard assumptions, the combustion process is modeled as a heat addition process, and the exhaust process as a heat rejection process.

9-6C The air standard assumptions are: (1) the working fluid is air which behaves as an ideal gas, (2) all the processes are internally reversible, (3) the combustion process is replaced by the heat addition process, and (4) the exhaust process is replaced by the heat rejection process which returns the working fluid to its original state.

9-7C The clearance volume is the minimum volume formed in the cylinder whereas the displacement volume is the volume displaced by the piston as the piston moves between the top dead center and the bottom dead center.

9-8C It is the ratio of the maximum to minimum volumes in the cylinder.

9-9C The MEP is the fictitious pressure which, if acted on the piston during the entire power stroke, would produce the same amount of net work as that produced during the actual cycle.

9-10C Yes.

9-11C Assuming no accumulation of carbon deposits on the piston face, the compression ratio will remain the same (otherwise it will increase). The mean effective pressure, on the other hand, will decrease as a car gets older as a result of wear and tear.

9-12C The SI and CI engines differ from each other in the way combustion is initiated; by a spark in SI engines, and by compressing the air above the self-ignition temperature of the fuel in CI engines.

9-13C Stroke is the distance between the TDC and the BDC, bore is the diameter of the cylinder, TDC is the position of the piston when it forms the smallest volume in the cylinder, and clearance volume is the minimum volume formed in the cylinder.

9-14 The temperatures of the energy reservoirs of an ideal gas power cycle are given. It is to be determined if this cycle can have a thermal efficiency greater than 55 percent.

Analysis The maximum efficiency any engine using the specified reservoirs can have is

$$\eta_{\text{th,Carnot}} = 1 - \frac{T_L}{T_H} = 1 - \frac{(17 + 273) \text{ K}}{(627 + 273) \text{ K}} = \mathbf{0.678}$$

Therefore, an efficiency of 55 percent is possible.

9-15 The four processes of an air-standard cycle are described. The cycle is to be shown on P - v and T - s diagrams, and the net work output and the thermal efficiency are to be determined.

Assumptions 1 The air-standard assumptions are applicable. **2** Kinetic and potential energy changes are negligible. **3** Air is an ideal gas with variable specific heats.

Properties The properties of air are given in Table A-17.

Analysis (b) The properties of air at various states are

$$T_1 = 300\text{K} \longrightarrow \begin{aligned} h_1 &= 300.19 \text{ kJ/kg} \\ P_{r_1} &= 1.386 \end{aligned}$$

$$P_{r_2} = \frac{P_2}{P_1} P_{r_1} = \frac{800 \text{ kPa}}{100 \text{ kPa}} (1.386) = 11.088 \longrightarrow \begin{aligned} u_2 &= 389.22 \text{ kJ/kg} \\ T_2 &= 539.8 \text{ K} \end{aligned}$$

$$T_3 = 1800 \text{ K} \longrightarrow \begin{aligned} u_3 &= 1487.2 \text{ kJ/kg} \\ P_{r_3} &= 1310 \end{aligned}$$

$$\frac{P_3 v_3}{T_3} = \frac{P_2 v_2}{T_2} \longrightarrow P_3 = \frac{T_3}{T_2} P_2 = \frac{1800 \text{ K}}{539.8 \text{ K}} (800 \text{ kPa}) = 2668 \text{ kPa}$$

$$P_{r_4} = \frac{P_4}{P_3} P_{r_3} = \frac{100 \text{ kPa}}{2668 \text{ kPa}} (1310) = 49.10 \longrightarrow h_4 = 828.1 \text{ kJ/kg}$$

From energy balances,

$$q_{\text{in}} = u_3 - u_2 = 1487.2 - 389.2 = 1098.0 \text{ kJ/kg}$$

$$q_{\text{out}} = h_4 - h_1 = 828.1 - 300.19 = 527.9 \text{ kJ/kg}$$

$$w_{\text{net,out}} = q_{\text{in}} - q_{\text{out}} = 1098.0 - 527.9 = \mathbf{570.1 \text{ kJ/kg}}$$

(c) Then the thermal efficiency becomes

$$\eta_{\text{th}} = \frac{w_{\text{net,out}}}{q_{\text{in}}} = \frac{570.1 \text{ kJ/kg}}{1098.0 \text{ kJ/kg}} = \mathbf{51.9\%}$$

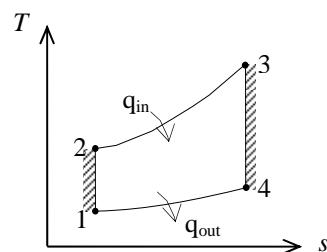
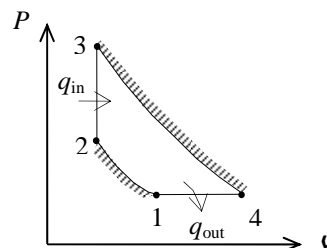

9-16 EES Problem 9-15 is reconsidered. The effect of the maximum temperature of the cycle on the net work output and thermal efficiency is to be investigated. Also, T - s and P - v diagrams for the cycle are to be plotted.

Analysis Using EES, the problem is solved as follows:

"Input Data"

T[1]=300 [K]
P[1]=100 [kPa]
P[2] = 800 [kPa]
T[3]=1800 [K]
P[4] = 100 [kPa]

"Process 1-2 is isentropic compression"

s[1]=entropy(air,T=T[1],P=P[1])
s[2]=s[1]
T[2]=temperature(air, s=s[2], P=P[2])
 $P[2]*v[2]/T[2]=P[1]*v[1]/T[1]$
 $P[1]*v[1]=R*T[1]$
R=0.287 [kJ/kg-K]
"Conservation of energy for process 1 to 2"
q_12 -w_12 = DELTAu_12
q_12 =0**"isentropic process"**
DELTAu_12=intenergy(air,T=T[2])-intenergy(air,T=T[1])

"Process 2-3 is constant volume heat addition"

s[3]=entropy(air, T=T[3], P=P[3])
 $\{P[3]*v[3]/T[3]=P[2]*v[2]/T[2]\}$
 $P[3]*v[3]=R*T[3]$
v[3]=v[2]
"Conservation of energy for process 2 to 3"
q_23 -w_23 = DELTAu_23
w_23 =0**"constant volume process"**
DELTAu_23=intenergy(air,T=T[3])-intenergy(air,T=T[2])

"Process 3-4 is isentropic expansion"

s[4]=entropy(air,T=T[4],P=P[4])
s[4]=s[3]
 $P[4]*v[4]/T[4]=P[3]*v[3]/T[3]$
 $\{P[4]*v[4]=0.287*T[4]\}$
"Conservation of energy for process 3 to 4"
q_34 -w_34 = DELTAu_34
q_34 =0**"isentropic process"**
DELTAu_34=intenergy(air,T=T[4])-intenergy(air,T=T[3])

"Process 4-1 is constant pressure heat rejection"

$\{P[4]*v[4]/T[4]=P[1]*v[1]/T[1]\}$
"Conservation of energy for process 4 to 1"
q_41 -w_41 = DELTAu_41
w_41 =P[1]*(v[1]-v[4]) **"constant pressure process"**
DELTAu_41=intenergy(air,T=T[1])-intenergy(air,T=T[4])
q_in_total=q_23

w_net = w_12+w_23+w_34+w_41
Eta_th=w_net/q_in_total*100 **"Thermal efficiency, in percent"**

T_3 [K]	η_{th}	$q_{in,total}$ [kJ/kg]	W_{net} [kJ/kg]
1500	50.91	815.4	415.1
1700	51.58	1002	516.8
1900	52.17	1192	621.7
2100	52.69	1384	729.2
2300	53.16	1579	839.1
2500	53.58	1775	951.2

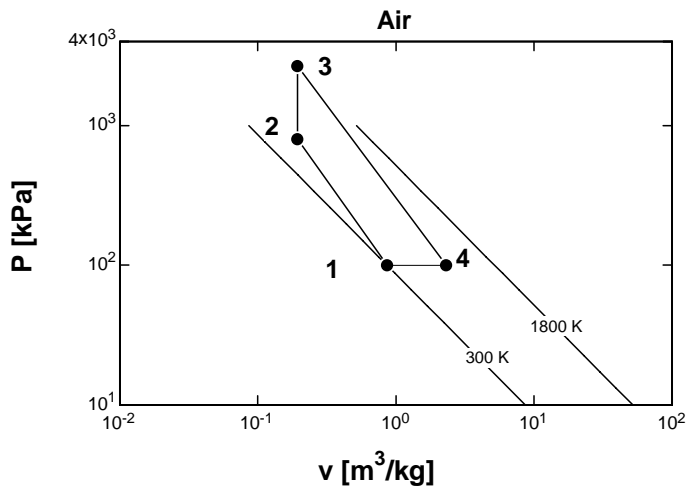
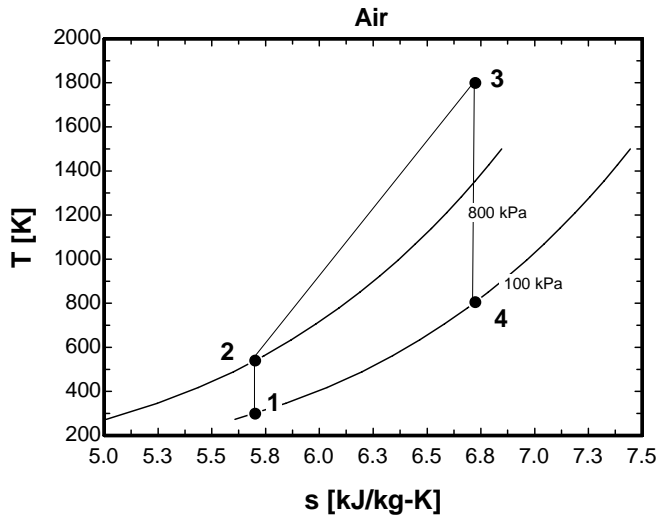

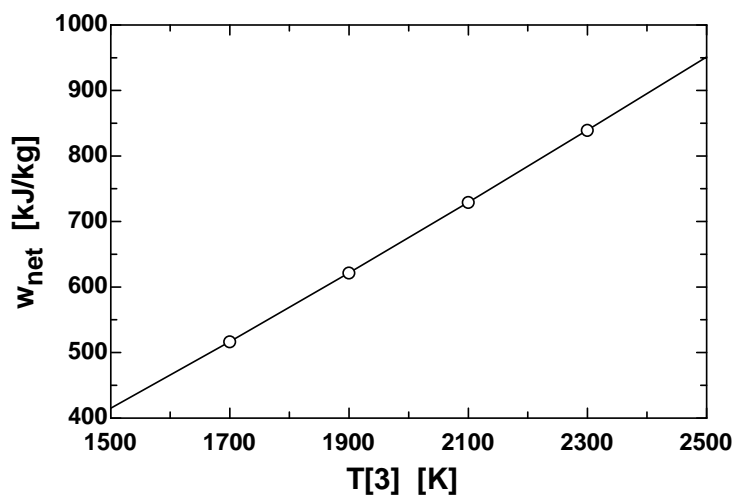
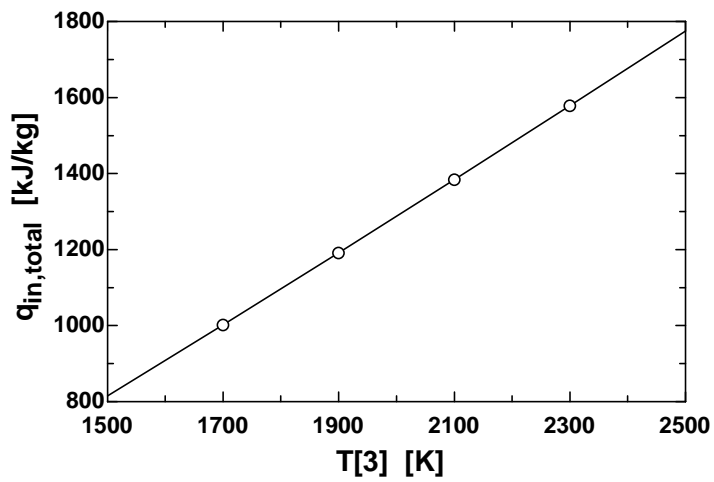
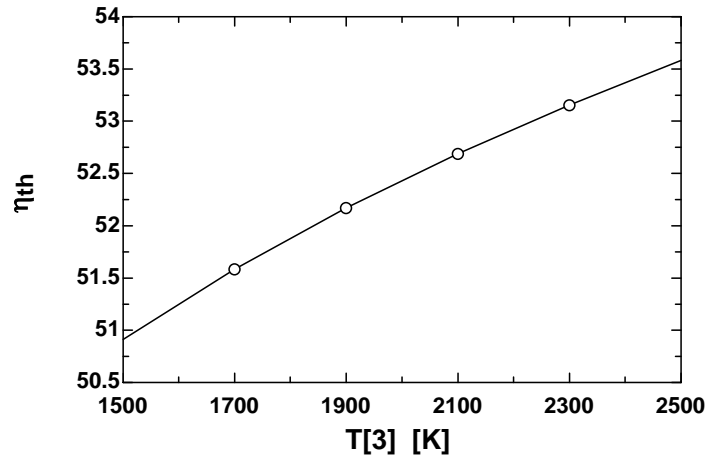

9-17 The four processes of an air-standard cycle are described. The cycle is to be shown on P - v and T - s diagrams, and the maximum temperature in the cycle and the thermal efficiency are to be determined.

Assumptions 1 The air-standard assumptions are applicable. **2** Kinetic and potential energy changes are negligible. **3** Air is an ideal gas with constant specific heats.

Properties The properties of air at room temperature are $c_p = 1.005 \text{ kJ/kg}\cdot\text{K}$, $c_v = 0.718 \text{ kJ/kg}\cdot\text{K}$, and $k = 1.4$ (Table A-2).

Analysis (b) From the ideal gas isentropic relations and energy balance,

$$T_2 = T_1 \left(\frac{P_2}{P_1} \right)^{(k-1)/k} = (300 \text{ K}) \left(\frac{1000 \text{ kPa}}{100 \text{ kPa}} \right)^{0.4/1.4} = 579.2 \text{ K}$$

$$q_{\text{in}} = h_3 - h_2 = c_p(T_3 - T_2)$$

$$2800 \text{ kJ/kg} = (1.005 \text{ kJ/kg}\cdot\text{K})(T_3 - 579.2) \longrightarrow T_{\text{max}} = T_3 = \mathbf{3360 \text{ K}}$$

$$(c) \quad \frac{P_3 v_3}{T_3} = \frac{P_4 v_4}{T_4} \longrightarrow T_4 = \frac{P_4}{P_3} T_3 = \frac{100 \text{ kPa}}{1000 \text{ kPa}} (3360 \text{ K}) = 336 \text{ K}$$

$$q_{\text{out}} = q_{34,\text{out}} + q_{41,\text{out}} = (u_3 - u_4) + (h_4 - h_1)$$

$$= c_v(T_3 - T_4) + c_p(T_4 - T_1)$$

$$= (0.718 \text{ kJ/kg}\cdot\text{K})(3360 - 336) \text{ K} + (1.005 \text{ kJ/kg}\cdot\text{K})(336 - 300) \text{ K}$$

$$= 2212 \text{ kJ/kg}$$

$$\eta_{\text{th}} = 1 - \frac{q_{\text{out}}}{q_{\text{in}}} = 1 - \frac{2212 \text{ kJ/kg}}{2800 \text{ kJ/kg}} = \mathbf{21.0\%}$$

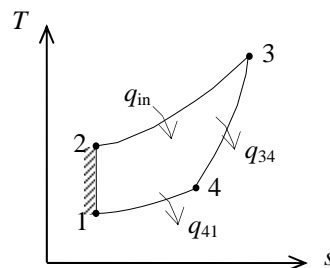
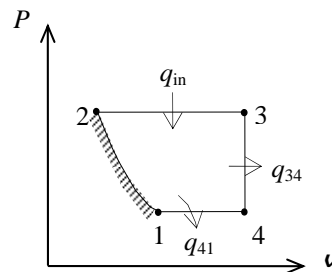

Discussion The assumption of constant specific heats at room temperature is not realistic in this case the temperature changes involved are too large.

9-18E The four processes of an air-standard cycle are described. The cycle is to be shown on P - v and T - s diagrams, and the total heat input and the thermal efficiency are to be determined.

Assumptions 1 The air-standard assumptions are applicable. **2** Kinetic and potential energy changes are negligible. **3** Air is an ideal gas with variable specific heats.

Properties The properties of air are given in Table A-17E.

Analysis (b) The properties of air at various states are

$$T_1 = 540 \text{ R} \longrightarrow u_1 = 92.04 \text{ Btu/lbm}, \quad h_1 = 129.06 \text{ Btu/lbm}$$

$$q_{\text{in},12} = u_2 - u_1 \longrightarrow u_2 = u_1 + q_{\text{in},12} = 92.04 + 300 = 392.04 \text{ Btu/lbm}$$

$$T_2 = 2116 \text{ R}, \quad h_2 = 537.1 \text{ Btu/lbm}$$

$$\frac{P_2 v_2}{T_2} = \frac{P_1 v_1}{T_1} \longrightarrow P_2 = \frac{T_2}{T_1} P_1 = \frac{2116 \text{ R}}{540 \text{ R}} (14.7 \text{ psia}) = 57.6 \text{ psia}$$

$$T_3 = 3200 \text{ R} \longrightarrow h_3 = 849.48 \text{ Btu/lbm}$$

$$P_{r_3} = 1242$$

$$P_{r_4} = \frac{P_4}{P_3} P_{r_3} = \frac{14.7 \text{ psia}}{57.6 \text{ psia}} (1242) = 317.0 \longrightarrow h_4 = 593.22 \text{ Btu/lbm}$$

From energy balance,

$$q_{23,\text{in}} = h_3 - h_2 = 849.48 - 537.1 = 312.38 \text{ Btu/lbm}$$

$$q_{\text{in}} = q_{12,\text{in}} + q_{23,\text{in}} = 300 + 312.38 = \mathbf{612.38 \text{ Btu/lbm}}$$

$$q_{\text{out}} = h_4 - h_1 = 593.22 - 129.06 = 464.16 \text{ Btu/lbm}$$

(c) Then the thermal efficiency becomes

$$\eta_{\text{th}} = 1 - \frac{q_{\text{out}}}{q_{\text{in}}} = 1 - \frac{464.16 \text{ Btu/lbm}}{612.38 \text{ Btu/lbm}} = \mathbf{24.2\%}$$

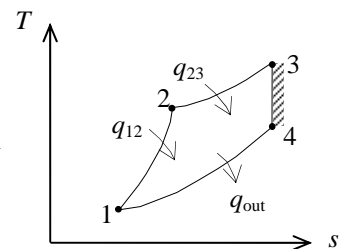
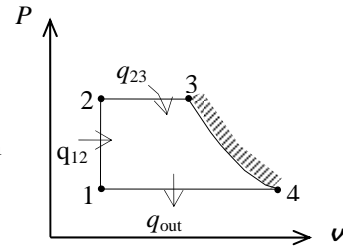

9-19E The four processes of an air-standard cycle are described. The cycle is to be shown on P - v and T - s diagrams, and the total heat input and the thermal efficiency are to be determined.

Assumptions 1 The air-standard assumptions are applicable. **2** Kinetic and potential energy changes are negligible. **3** Air is an ideal gas with constant specific heats.

Properties The properties of air at room temperature are $c_p = 0.240$ Btu/lbm·R, $c_v = 0.171$ Btu/lbm·R, and $k = 1.4$ (Table A-2E).

Analysis (b)

$$q_{in,12} = u_2 - u_1 = c_v(T_2 - T_1)$$

$$300 \text{ Btu/lbm} = (0.171 \text{ Btu/lbm}\cdot\text{R})(T_2 - 540)\text{R}$$

$$T_2 = 2294 \text{ R}$$

$$\frac{P_2 v_2}{T_2} = \frac{P_1 v_1}{T_1} \longrightarrow P_2 = \frac{T_2}{T_1} P_1 = \frac{2294 \text{ R}}{540 \text{ R}} (14.7 \text{ psia}) = 62.46 \text{ psia}$$

$$q_{in,23} = h_3 - h_2 = c_p(T_3 - T_2) = (0.24 \text{ Btu/lbm}\cdot\text{R})(3200 - 2294)\text{R} = 217.4 \text{ Btu/lbm}$$

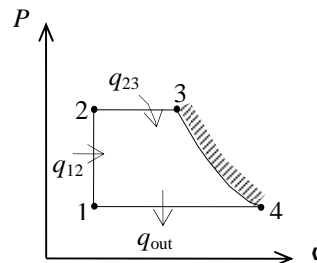

Process 3-4 is isentropic:

$$T_4 = T_3 \left(\frac{P_4}{P_3} \right)^{(k-1)/k} = (3200 \text{ R}) \left(\frac{14.7 \text{ psia}}{62.46 \text{ psia}} \right)^{0.4/1.4} = 2117 \text{ R}$$

$$q_{in} = q_{in,12} + q_{in,23} = 300 + 217.4 = \mathbf{517.4 \text{ Btu/lbm}}$$

$$q_{out} = h_4 - h_1 = c_p(T_4 - T_1) = (0.240 \text{ Btu/lbm}\cdot\text{R})(2117 - 540) = 378.5 \text{ Btu/lbm}$$

$$(c) \quad \eta_{th} = 1 - \frac{q_{out}}{q_{in}} = 1 - \frac{378.5 \text{ Btu/lbm}}{517.4 \text{ Btu/lbm}} = \mathbf{26.8\%}$$

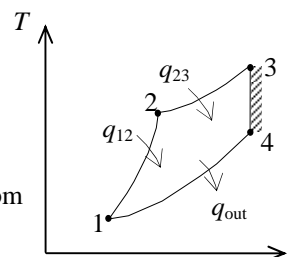

9-20 The three processes of an air-standard cycle are described. The cycle is to be shown on P - v and T - s diagrams, and the heat rejected and the thermal efficiency are to be determined.

Assumptions 1 The air-standard assumptions are applicable. **2** Kinetic and potential energy changes are negligible. **3** Air is an ideal gas with constant specific heats.

Properties The properties of air at room temperature are $c_p = 1.005 \text{ kJ/kg}\cdot\text{K}$, $c_v = 0.718 \text{ kJ/kg}\cdot\text{K}$, and $k = 1.4$ (Table A-2).

Analysis (b)

$$T_2 = T_1 \left(\frac{P_2}{P_1} \right)^{(k-1)/k} = (300 \text{ K}) \left(\frac{1000 \text{ kPa}}{100 \text{ kPa}} \right)^{0.4/1.4} = 579.2 \text{ K}$$

$$Q_{\text{in}} = m(h_3 - h_2) = mc_p(T_3 - T_2)$$

$$2.76 \text{ kJ} = (0.004 \text{ kg})(1.005 \text{ kJ/kg}\cdot\text{K})(T_3 - 579.2) \longrightarrow T_3 = 1266 \text{ K}$$

Process 3-1 is a straight line on the P - v diagram, thus the w_{31} is simply the area under the process curve,

$$w_{31} = \text{area} = \frac{P_3 + P_1}{2} (v_1 - v_3) = \frac{P_3 + P_1}{2} \left(\frac{RT_1}{P_1} - \frac{RT_3}{P_3} \right)$$

$$= \left(\frac{1000 + 100 \text{ kPa}}{2} \right) \left(\frac{300 \text{ K}}{100 \text{ kPa}} - \frac{1266 \text{ K}}{1000 \text{ kPa}} \right) (0.287 \text{ kJ/kg}\cdot\text{K})$$

$$= 273.7 \text{ kJ/kg}$$

Energy balance for process 3-1 gives

$$E_{\text{in}} - E_{\text{out}} = \Delta E_{\text{system}} \longrightarrow -Q_{31,\text{out}} - W_{31,\text{out}} = m(u_1 - u_3)$$

$$Q_{31,\text{out}} = -mw_{31,\text{out}} - mc_v(T_1 - T_3) = -m[w_{31,\text{out}} + c_v(T_1 - T_3)]$$

$$= -(0.004 \text{ kg})[273.7 + (0.718 \text{ kJ/kg}\cdot\text{K})(300 - 1266)\text{K}] = \mathbf{1.679 \text{ kJ}}$$

$$(c) \quad \eta_{\text{th}} = 1 - \frac{Q_{\text{out}}}{Q_{\text{in}}} = 1 - \frac{1.679 \text{ kJ}}{2.76 \text{ kJ}} = \mathbf{39.2\%}$$

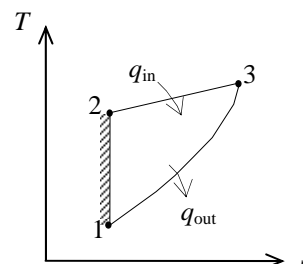
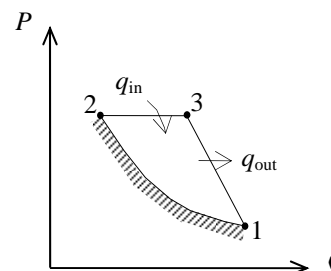

9-21 The three processes of an air-standard cycle are described. The cycle is to be shown on P - v and T - s diagrams, and the net work per cycle and the thermal efficiency are to be determined.

Assumptions 1 The air-standard assumptions are applicable. **2** Kinetic and potential energy changes are negligible. **3** Air is an ideal gas with variable specific heats.

Properties The properties of air are given in Table A-17.

Analysis (b) The properties of air at various states are

$$T_1 = 290 \text{ K} \longrightarrow \begin{aligned} u_1 &= 206.91 \text{ kJ/kg} \\ h_1 &= 290.16 \text{ kJ/kg} \end{aligned}$$

$$\frac{P_2 v_2}{T_2} = \frac{P_1 v_1}{T_1} \longrightarrow T_2 = \frac{P_2}{P_1} T_1 = \frac{380 \text{ kPa}}{95 \text{ kPa}} (290 \text{ K}) = 1160 \text{ K}$$

$$\longrightarrow u_2 = 897.91 \text{ kJ/kg}, P_{r_2} = 207.2$$

$$P_{r_3} = \frac{P_3}{P_2} P_{r_2} = \frac{95 \text{ kPa}}{380 \text{ kPa}} (207.2) = 51.8 \longrightarrow h_3 = 840.38 \text{ kJ/kg}$$

$$Q_{\text{in}} = m(u_2 - u_1) = (0.003 \text{ kg})(897.91 - 206.91) \text{ kJ/kg} = 2.073 \text{ kJ}$$

$$Q_{\text{out}} = m(h_3 - h_1) = (0.003 \text{ kg})(840.38 - 290.16) \text{ kJ/kg} = 1.651 \text{ kJ}$$

$$W_{\text{net,out}} = Q_{\text{in}} - Q_{\text{out}} = 2.073 - 1.651 = \mathbf{0.422 \text{ kJ}}$$

$$(c) \quad \eta_{\text{th}} = \frac{W_{\text{net,out}}}{Q_{\text{in}}} = \frac{0.422 \text{ kJ}}{2.073 \text{ kJ}} = \mathbf{20.4\%}$$

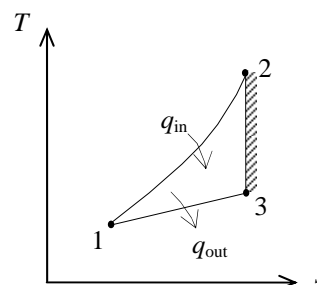
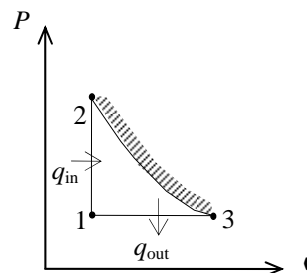

9-22 The three processes of an air-standard cycle are described. The cycle is to be shown on P - v and T - s diagrams, and the net work per cycle and the thermal efficiency are to be determined.

Assumptions 1 The air-standard assumptions are applicable. **2** Kinetic and potential energy changes are negligible. **3** Air is an ideal gas with constant specific heats.

Properties The properties of air at room temperature are $c_p = 1.005$ kJ/kg·K, $c_v = 0.718$ kJ/kg·K, and $k = 1.4$ (Table A-2).

Analysis (b) From the isentropic relations and energy balance,

$$\frac{P_2 v_2}{T_2} = \frac{P_1 v_1}{T_1} \longrightarrow T_2 = \frac{P_2}{P_1} T_1 = \frac{380 \text{ kPa}}{95 \text{ kPa}} (290 \text{ K}) = 1160 \text{ K}$$

$$T_3 = T_2 \left(\frac{P_3}{P_2} \right)^{(k-1)/k} = (1160 \text{ K}) \left(\frac{95 \text{ kPa}}{380 \text{ kPa}} \right)^{0.4/1.4} = 780.6 \text{ K}$$

$$\begin{aligned} Q_{\text{in}} &= m(u_2 - u_1) = mc_v(T_2 - T_1) \\ &= (0.003 \text{ kg})(0.718 \text{ kJ/kg} \cdot \text{K})(1160 - 290) \text{ K} = 1.87 \text{ kJ} \end{aligned}$$

$$\begin{aligned} Q_{\text{out}} &= m(h_3 - h_1) = mc_p(T_3 - T_1) \\ &= (0.003 \text{ kg})(1.005 \text{ kJ/kg} \cdot \text{K})(780.6 - 290) \text{ K} = 1.48 \text{ kJ} \end{aligned}$$

$$W_{\text{net,out}} = Q_{\text{in}} - Q_{\text{out}} = 1.87 - 1.48 = \mathbf{0.39 \text{ kJ}}$$

$$(c) \quad \eta_{\text{th}} = \frac{W_{\text{net}}}{Q_{\text{in}}} = \frac{0.39 \text{ kJ}}{1.87 \text{ kJ}} = \mathbf{20.9\%}$$

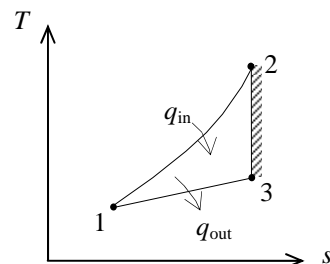
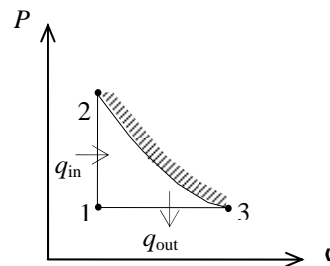

9-23 A Carnot cycle with the specified temperature limits is considered. The net work output per cycle is to be determined.

Assumptions Air is an ideal gas with constant specific heats.

Properties The properties of air at room temperature are $c_p = 1.005 \text{ kJ/kg}\cdot\text{K}$, $c_v = 0.718 \text{ kJ/kg}\cdot\text{K}$, $R = 0.287 \text{ kJ/kg}\cdot\text{K}$, and $k = 1.4$ (Table A-2).

Analysis The minimum pressure in the cycle is P_3 and the maximum pressure is P_1 . Then,

$$\frac{T_2}{T_3} = \left(\frac{P_2}{P_3}\right)^{(k-1)/k}$$

or

$$P_2 = P_3 \left(\frac{T_2}{T_3}\right)^{k/(k-1)} = (20 \text{ kPa}) \left(\frac{900 \text{ K}}{300 \text{ K}}\right)^{1.4/0.4} = 935.3 \text{ kPa}$$

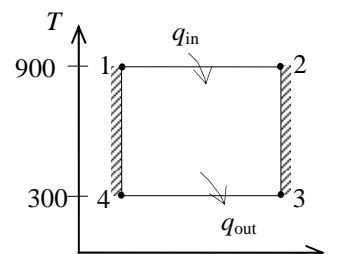

The heat input is determined from

$$s_2 - s_1 = c_p \ln \frac{T_2}{T_1} - R \ln \frac{P_2}{P_1} = -(0.287 \text{ kJ/kg}\cdot\text{K}) \ln \frac{935.3 \text{ kPa}}{2000 \text{ kPa}} = 0.2181 \text{ kJ/kg}\cdot\text{K}$$

$$Q_{\text{in}} = mT_H (s_2 - s_1) = (0.003 \text{ kg})(900 \text{ K})(0.2181 \text{ kJ/kg}\cdot\text{K}) = 0.5889 \text{ kJ}$$

Then,

$$\eta_{\text{th}} = 1 - \frac{T_L}{T_H} = 1 - \frac{300 \text{ K}}{900 \text{ K}} = 66.7\%$$

$$W_{\text{net,out}} = \eta_{\text{th}} Q_{\text{in}} = (0.667)(0.5889 \text{ kJ}) = \mathbf{0.393 \text{ kJ}}$$

9-24 A Carnot cycle executed in a closed system with air as the working fluid is considered. The minimum pressure in the cycle, the heat rejection from the cycle, the thermal efficiency of the cycle, and the second-law efficiency of an actual cycle operating between the same temperature limits are to be determined.

Assumptions Air is an ideal gas with constant specific heats.

Properties The properties of air at room temperatures are $R = 0.287 \text{ kJ/kg}\cdot\text{K}$ and $k = 1.4$ (Table A-2).

Analysis (a) The minimum temperature is determined from

$$w_{\text{net}} = (s_2 - s_1)(T_H - T_L) \longrightarrow 100 \text{ kJ/kg} = (0.25 \text{ kJ/kg}\cdot\text{K})(750 - T_L)\text{K} \longrightarrow T_L = 350 \text{ K}$$

The pressure at state 4 is determined from

$$\frac{T_1}{T_4} = \left(\frac{P_1}{P_4}\right)^{(k-1)/k}$$

or

$$P_1 = P_4 \left(\frac{T_1}{T_4}\right)^{k/(k-1)}$$

$$800 \text{ kPa} = P_4 \left(\frac{750 \text{ K}}{350 \text{ K}}\right)^{1.4/0.4} \longrightarrow P_4 = 110.1 \text{ kPa}$$

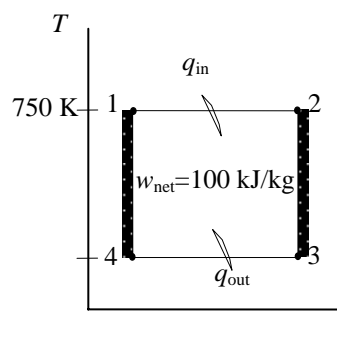

The minimum pressure in the cycle is determined from

$$\Delta s_{12} = -\Delta s_{34} = c_p \ln \frac{T_4}{T_3} - R \ln \frac{P_4}{P_3}$$

$$-0.25 \text{ kJ/kg}\cdot\text{K} = -(0.287 \text{ kJ/kg}\cdot\text{K}) \ln \frac{110.1 \text{ kPa}}{P_3} \longrightarrow P_3 = 46.1 \text{ kPa}$$

(b) The heat rejection from the cycle is

$$q_{\text{out}} = T_L \Delta s_{12} = (350 \text{ K})(0.25 \text{ kJ/kg}\cdot\text{K}) = 87.5 \text{ kJ/kg}$$

(c) The thermal efficiency is determined from

$$\eta_{\text{th}} = 1 - \frac{T_L}{T_H} = 1 - \frac{350 \text{ K}}{750 \text{ K}} = 0.533$$

(d) The power output for the Carnot cycle is

$$\dot{W}_{\text{Carnot}} = \dot{m} w_{\text{net}} = (90 \text{ kg/s})(100 \text{ kJ/kg}) = 9000 \text{ kW}$$

Then, the second-law efficiency of the actual cycle becomes

$$\eta_{\text{II}} = \frac{\dot{W}_{\text{actual}}}{\dot{W}_{\text{Carnot}}} = \frac{5200 \text{ kW}}{9000 \text{ kW}} = 0.578$$

9-25 An ideal gas Carnot cycle with air as the working fluid is considered. The maximum temperature of the low-temperature energy reservoir, the cycle's thermal efficiency, and the amount of heat that must be supplied per cycle are to be determined.

Assumptions 1 The air-standard assumptions are applicable. 2 Kinetic and potential energy changes are negligible. 3 Air is an ideal gas with constant specific heats.

Properties The properties of air at room temperature are $c_p = 1.005 \text{ kJ/kg}\cdot\text{K}$, $c_v = 0.718 \text{ kJ/kg}\cdot\text{K}$, and $k = 1.4$ (Table A-2a).

Analysis The temperature of the low-temperature reservoir can be found by applying the isentropic expansion process relation

$$T_1 = T_2 \left(\frac{v_2}{v_1} \right)^{k-1} = (1027 + 273 \text{ K}) \left(\frac{1}{12} \right)^{1.4-1} = \mathbf{481.1 \text{ K}}$$

Since the Carnot engine is completely reversible, its efficiency is

$$\eta_{\text{th,Carnot}} = 1 - \frac{T_L}{T_H} = 1 - \frac{481.1 \text{ K}}{(1027 + 273) \text{ K}} = \mathbf{0.630}$$

The work output per cycle is

$$W_{\text{net}} = \frac{\dot{W}_{\text{net}}}{\dot{n}} = \frac{500 \text{ kJ/s}}{1500 \text{ cycle/min}} \left(\frac{60 \text{ s}}{1 \text{ min}} \right) = 20 \text{ kJ/cycle}$$

According to the definition of the cycle efficiency,

$$\eta_{\text{th,Carnot}} = \frac{W_{\text{net}}}{Q_{\text{in}}} \rightarrow Q_{\text{in}} = \frac{W_{\text{net}}}{\eta_{\text{th,Carnot}}} = \frac{20 \text{ kJ/cycle}}{0.63} = \mathbf{31.75 \text{ kJ/cycle}}$$

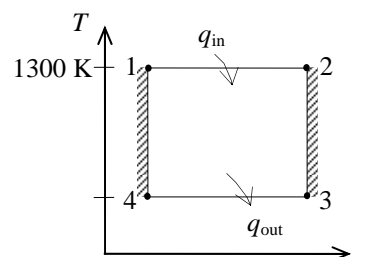

9-26E The temperatures of the energy reservoirs of an ideal gas Carnot cycle are given. The heat supplied and the work produced per cycle are to be determined.

Analysis According to the thermodynamic definition of temperature,

$$Q_H = Q_L \frac{T_H}{T_L} = (100 \text{ Btu}) \frac{(1240 + 460) \text{ R}}{(40 + 460) \text{ R}} = \mathbf{340 \text{ Btu/cycle}}$$

Applying the first law to the cycle gives

$$W_{\text{net}} = Q_H - Q_L = 340 - 100 = \mathbf{240 \text{ Btu/cycle}}$$

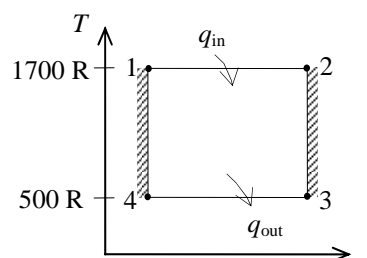

Otto Cycle

9-27C The four processes that make up the Otto cycle are (1) isentropic compression, (2) $v = \text{constant}$ heat addition, (3) isentropic expansion, and (4) $v = \text{constant}$ heat rejection.

9-28C The ideal Otto cycle involves external irreversibilities, and thus it has a lower thermal efficiency.

9-29C For actual four-stroke engines, the rpm is twice the number of thermodynamic cycles; for two-stroke engines, it is equal to the number of thermodynamic cycles.

9-30C They are analyzed as closed system processes because no mass crosses the system boundaries during any of the processes.

9-31C It increases with both of them.

9-32C Because high compression ratios cause engine knock.

9-33C The thermal efficiency will be the highest for argon because it has the highest specific heat ratio, $k = 1.667$.

9-34C The fuel is injected into the cylinder in both engines, but it is ignited with a spark plug in gasoline engines.

9-35 An ideal Otto cycle is considered. The thermal efficiency and the rate of heat input are to be determined.

Assumptions **1** The air-standard assumptions are applicable. **2** Kinetic and potential energy changes are negligible. **3** Air is an ideal gas with constant specific heats.

Properties The properties of air at room temperature are $c_p = 1.005 \text{ kJ/kg}\cdot\text{K}$, $c_v = 0.718 \text{ kJ/kg}\cdot\text{K}$, and $k = 1.4$ (Table A-2a).

Analysis The definition of cycle thermal efficiency reduces to

$$\eta_{\text{th}} = 1 - \frac{1}{r^{k-1}} = 1 - \frac{1}{12^{1.4-1}} = \mathbf{0.630}$$

The rate of heat addition is then

$$\dot{Q}_{\text{in}} = \frac{\dot{W}_{\text{net}}}{\eta_{\text{th}}} = \frac{200 \text{ kW}}{0.630} = \mathbf{318 \text{ kW}}$$

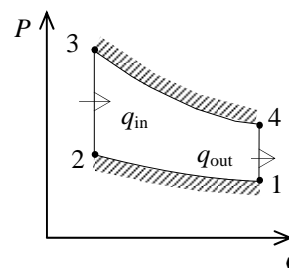

9-36 An ideal Otto cycle is considered. The thermal efficiency and the rate of heat input are to be determined.

Assumptions **1** The air-standard assumptions are applicable. **2** Kinetic and potential energy changes are negligible. **3** Air is an ideal gas with constant specific heats.

Properties The properties of air at room temperature are $c_p = 1.005 \text{ kJ/kg}\cdot\text{K}$, $c_v = 0.718 \text{ kJ/kg}\cdot\text{K}$, and $k = 1.4$ (Table A-2a).

Analysis The definition of cycle thermal efficiency reduces to

$$\eta_{\text{th}} = 1 - \frac{1}{r^{k-1}} = 1 - \frac{1}{10^{1.4-1}} = \mathbf{0.602}$$

The rate of heat addition is then

$$\dot{Q}_{\text{in}} = \frac{\dot{W}_{\text{net}}}{\eta_{\text{th}}} = \frac{200 \text{ kW}}{0.602} = \mathbf{332 \text{ kW}}$$

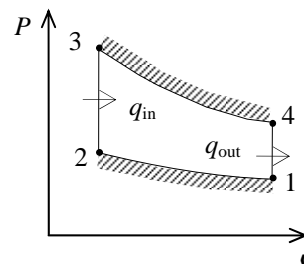

9-37E An Otto cycle with non-isentropic compression and expansion processes is considered. The thermal efficiency, the heat addition, and the mean effective pressure are to be determined.

Assumptions 1 The air-standard assumptions are applicable. **2** Kinetic and potential energy changes are negligible. **3** Air is an ideal gas with constant specific heats.

Properties The properties of air at room temperature are $R = 0.3704 \text{ psia}\cdot\text{ft}^3/\text{lbm}\cdot\text{R}$ (Table A-1E), $c_p = 0.240 \text{ Btu}/\text{lbm}\cdot\text{R}$, $c_v = 0.171 \text{ Btu}/\text{lbm}\cdot\text{R}$, and $k = 1.4$ (Table A-2Ea).

Analysis We begin by determining the temperatures of the cycle states using the process equations and component efficiencies. The ideal temperature at the end of the compression is then

$$T_{2s} = T_1 \left(\frac{\nu_1}{\nu_2} \right)^{k-1} = T_1 r^{k-1} = (520 \text{ R})(8)^{1.4-1} = 1195 \text{ R}$$

With the isentropic compression efficiency, the actual temperature at the end of the compression is

$$\eta = \frac{T_2 - T_1}{T_{2s} - T_1} \longrightarrow T_2 = T_1 + \frac{T_{2s} - T_1}{\eta} = (520 \text{ R}) + \frac{(1195 - 520) \text{ R}}{0.85} = 1314 \text{ R}$$

Similarly for the expansion,

$$T_{4s} = T_3 \left(\frac{\nu_3}{\nu_4} \right)^{k-1} = T_3 \left(\frac{1}{r} \right)^{k-1} = (2300 + 460 \text{ R}) \left(\frac{1}{8} \right)^{1.4-1} = 1201 \text{ R}$$

$$\eta = \frac{T_3 - T_4}{T_3 - T_{4s}} \longrightarrow T_4 = T_3 - \eta(T_3 - T_{4s}) = (2760 \text{ R}) - (0.95)(2760 - 1201) \text{ R} = 1279 \text{ R}$$

The specific heat addition is that of process 2-3,

$$q_{\text{in}} = c_v(T_3 - T_2) = (0.171 \text{ Btu}/\text{lbm}\cdot\text{R})(2760 - 1314) \text{ R} = \mathbf{247.3 \text{ Btu}/\text{lbm}}$$

The net work production is the difference between the work produced by the expansion and that used by the compression,

$$\begin{aligned} w_{\text{net}} &= c_v(T_3 - T_4) - c_v(T_2 - T_1) \\ &= (0.171 \text{ Btu}/\text{lbm}\cdot\text{R})(2760 - 1279) \text{ R} - (0.171 \text{ Btu}/\text{lbm}\cdot\text{R})(1314 - 520) \text{ R} \\ &= 117.5 \text{ Btu}/\text{lbm} \end{aligned}$$

The thermal efficiency of this cycle is then

$$\eta_{\text{th}} = \frac{w_{\text{net}}}{q_{\text{in}}} = \frac{117.5 \text{ Btu}/\text{lbm}}{247.3 \text{ Btu}/\text{lbm}} = \mathbf{0.475}$$

At the beginning of compression, the maximum specific volume of this cycle is

$$\nu_1 = \frac{RT_1}{P_1} = \frac{(0.3704 \text{ psia}\cdot\text{ft}^3/\text{lbm}\cdot\text{R})(520 \text{ R})}{13 \text{ psia}} = 14.82 \text{ ft}^3/\text{lbm}$$

while the minimum specific volume of the cycle occurs at the end of the compression

$$\nu_2 = \frac{\nu_1}{r} = \frac{14.82 \text{ ft}^3/\text{lbm}}{8} = 1.852 \text{ ft}^3/\text{lbm}$$

The engine's mean effective pressure is then

$$\text{MEP} = \frac{w_{\text{net}}}{\nu_1 - \nu_2} = \frac{117.5 \text{ Btu}/\text{lbm}}{(14.82 - 1.852) \text{ ft}^3/\text{lbm}} \left(\frac{5.404 \text{ psia}\cdot\text{ft}^3}{1 \text{ Btu}} \right) = \mathbf{49.0 \text{ psia}}$$

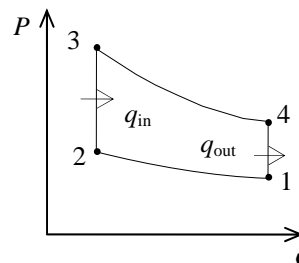

9-38 An ideal Otto cycle with air as the working fluid has a compression ratio of 9.5. The highest pressure and temperature in the cycle, the amount of heat transferred, the thermal efficiency, and the mean effective pressure are to be determined.

Assumptions **1** The air-standard assumptions are applicable. **2** Kinetic and potential energy changes are negligible. **3** Air is an ideal gas with constant specific heats.

Properties The properties of air at room temperature are $c_p = 1.005 \text{ kJ/kg}\cdot\text{K}$, $c_v = 0.718 \text{ kJ/kg}\cdot\text{K}$, $R = 0.287 \text{ kJ/kg}\cdot\text{K}$, and $k = 1.4$ (Table A-2).

Analysis (a) Process 1-2: isentropic compression.

$$T_2 = T_1 \left(\frac{\nu_1}{\nu_2} \right)^{k-1} = (308 \text{ K})(9.5)^{0.4} = 757.9 \text{ K}$$

$$\frac{P_2 \nu_2}{T_2} = \frac{P_1 \nu_1}{T_1} \longrightarrow P_2 = \frac{\nu_1}{\nu_2} \frac{T_2}{T_1} P_1 = (9.5) \left(\frac{757.9 \text{ K}}{308 \text{ K}} \right) (100 \text{ kPa}) = 2338 \text{ kPa}$$

Process 3-4: isentropic expansion.

$$T_3 = T_4 \left(\frac{\nu_4}{\nu_3} \right)^{k-1} = (800 \text{ K})(9.5)^{0.4} = \mathbf{1969 \text{ K}}$$

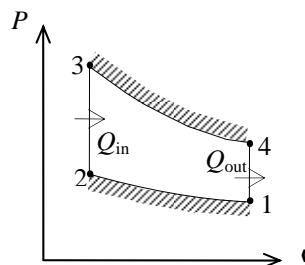

Process 2-3: $\nu = \text{constant}$ heat addition.

$$\frac{P_3 \nu_3}{T_3} = \frac{P_2 \nu_2}{T_2} \longrightarrow P_3 = \frac{T_3}{T_2} P_2 = \left(\frac{1969 \text{ K}}{757.9 \text{ K}} \right) (2338 \text{ kPa}) = \mathbf{6072 \text{ kPa}}$$

$$(b) \quad m = \frac{P_1 \nu_1}{RT_1} = \frac{(100 \text{ kPa})(0.0006 \text{ m}^3)}{(0.287 \text{ kPa}\cdot\text{m}^3/\text{kg}\cdot\text{K})(308 \text{ K})} = 6.788 \times 10^{-4} \text{ kg}$$

$$Q_{\text{in}} = m(u_3 - u_2) = mc_\nu(T_3 - T_2) = (6.788 \times 10^{-4} \text{ kg})(0.718 \text{ kJ/kg}\cdot\text{K})(1969 - 757.9) \text{ K} = \mathbf{0.590 \text{ kJ}}$$

(c) Process 4-1: $\nu = \text{constant}$ heat rejection.

$$Q_{\text{out}} = m(u_4 - u_1) = mc_\nu(T_4 - T_1) = -(6.788 \times 10^{-4} \text{ kg})(0.718 \text{ kJ/kg}\cdot\text{K})(800 - 308) \text{ K} = \mathbf{0.240 \text{ kJ}}$$

$$W_{\text{net}} = Q_{\text{in}} - Q_{\text{out}} = 0.590 - 0.240 = 0.350 \text{ kJ}$$

$$\eta_{\text{th}} = \frac{W_{\text{net,out}}}{Q_{\text{in}}} = \frac{0.350 \text{ kJ}}{0.590 \text{ kJ}} = \mathbf{59.4\%}$$

$$(d) \quad \nu_{\text{min}} = \nu_2 = \frac{\nu_{\text{max}}}{r}$$

$$\text{MEP} = \frac{W_{\text{net,out}}}{\nu_1 - \nu_2} = \frac{W_{\text{net,out}}}{\nu_1(1 - 1/r)} = \frac{0.350 \text{ kJ}}{(0.0006 \text{ m}^3)(1 - 1/9.5)} \left(\frac{\text{kPa}\cdot\text{m}^3}{\text{kJ}} \right) = \mathbf{652 \text{ kPa}}$$

9-39 An Otto cycle with air as the working fluid has a compression ratio of 9.5. The highest pressure and temperature in the cycle, the amount of heat transferred, the thermal efficiency, and the mean effective pressure are to be determined.

Assumptions 1 The air-standard assumptions are applicable. **2**

Kinetic and potential energy changes are negligible. **3** Air is an ideal gas with constant specific heats.

Properties The properties of air at room temperature are $c_p = 1.005 \text{ kJ/kg}\cdot\text{K}$, $c_v = 0.718 \text{ kJ/kg}\cdot\text{K}$, $R = 0.287 \text{ kJ/kg}\cdot\text{K}$, and $k = 1.4$ (Table A-2).

Analysis (a) Process 1-2: isentropic compression.

$$T_2 = T_1 \left(\frac{v_1}{v_2} \right)^{k-1} = (308 \text{ K})(9.5)^{0.4} = 757.9 \text{ K}$$

$$\frac{P_2 v_2}{T_2} = \frac{P_1 v_1}{T_1} \longrightarrow P_2 = \frac{v_1}{v_2} \frac{T_2}{T_1} P_1 = (9.5) \left(\frac{757.9 \text{ K}}{308 \text{ K}} \right) (100 \text{ kPa}) = 2338 \text{ kPa}$$

Process 3-4: polytropic expansion.

$$m = \frac{P_1 v_1}{RT_1} = \frac{(100 \text{ kPa})(0.0006 \text{ m}^3)}{(0.287 \text{ kPa}\cdot\text{m}^3/\text{kg}\cdot\text{K})(308 \text{ K})} = 6.788 \times 10^{-4} \text{ kg}$$

$$T_3 = T_4 \left(\frac{v_4}{v_3} \right)^{n-1} = (800 \text{ K})(9.5)^{0.35} = 1759 \text{ K}$$

$$W_{34} = \frac{mR(T_4 - T_3)}{1-n} = \frac{(6.788 \times 10^{-4} \text{ kg})(0.287 \text{ kJ/kg}\cdot\text{K})(800 - 1759) \text{ K}}{1-1.35} = 0.5338 \text{ kJ}$$

Then energy balance for process 3-4 gives

$$E_{\text{in}} - E_{\text{out}} = \Delta E_{\text{system}}$$

$$Q_{34,\text{in}} - W_{34,\text{out}} = m(u_4 - u_3)$$

$$Q_{34,\text{in}} = m(u_4 - u_3) + W_{34,\text{out}} = mc_v(T_4 - T_3) + W_{34,\text{out}}$$

$$Q_{34,\text{in}} = (6.788 \times 10^{-4} \text{ kg})(0.718 \text{ kJ/kg}\cdot\text{K})(800 - 1759) \text{ K} + 0.5338 \text{ kJ} = 0.0664 \text{ kJ}$$

That is, 0.066 kJ of heat is added to the air during the expansion process (This is not realistic, and probably is due to assuming constant specific heats at room temperature).

(b) Process 2-3: $v = \text{constant}$ heat addition.

$$\frac{P_3 v_3}{T_3} = \frac{P_2 v_2}{T_2} \longrightarrow P_3 = \frac{T_3}{T_2} P_2 = \left(\frac{1759 \text{ K}}{757.9 \text{ K}} \right) (2338 \text{ kPa}) = 5426 \text{ kPa}$$

$$Q_{23,\text{in}} = m(u_3 - u_2) = mc_v(T_3 - T_2)$$

$$Q_{23,\text{in}} = (6.788 \times 10^{-4} \text{ kg})(0.718 \text{ kJ/kg}\cdot\text{K})(1759 - 757.9) \text{ K} = 0.4879 \text{ kJ}$$

Therefore, $Q_{\text{in}} = Q_{23,\text{in}} + Q_{34,\text{in}} = 0.4879 + 0.0664 = 0.5543 \text{ kJ}$

(c) Process 4-1: $v = \text{constant}$ heat rejection.

$$Q_{\text{out}} = m(u_4 - u_1) = mc_v(T_4 - T_1) = (6.788 \times 10^{-4} \text{ kg})(0.718 \text{ kJ/kg}\cdot\text{K})(800 - 308) \text{ K} = 0.2398 \text{ kJ}$$

$$W_{\text{net,out}} = Q_{\text{in}} - Q_{\text{out}} = 0.5543 - 0.2398 = 0.3145 \text{ kJ}$$

$$\eta_{\text{th}} = \frac{W_{\text{net,out}}}{Q_{\text{in}}} = \frac{0.3145 \text{ kJ}}{0.5543 \text{ kJ}} = 56.7\%$$

(d) $v_{\text{min}} = v_2 = \frac{v_{\text{max}}}{r}$

$$\text{MEP} = \frac{W_{\text{net,out}}}{v_1 - v_2} = \frac{W_{\text{net,out}}}{v_1(1 - 1/r)} = \frac{0.3145 \text{ kJ}}{(0.0006 \text{ m}^3)(1 - 1/9.5)} \left(\frac{\text{kPa}\cdot\text{m}^3}{\text{kJ}} \right) = 586 \text{ kPa}$$

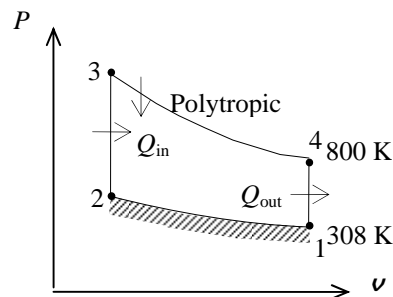

9-40E An ideal Otto cycle with air as the working fluid has a compression ratio of 8. The amount of heat transferred to the air during the heat addition process, the thermal efficiency, and the thermal efficiency of a Carnot cycle operating between the same temperature limits are to be determined.

Assumptions 1 The air-standard assumptions are applicable. 2 Kinetic and potential energy changes are negligible. 3 Air is an ideal gas with variable specific heats.

Properties The properties of air are given in Table A-17E.

Analysis (a) Process 1-2: isentropic compression.

$$T_1 = 540\text{R} \longrightarrow \begin{aligned} u_1 &= 92.04 \text{ Btu/lbm} \\ v_{r_1} &= 144.32 \end{aligned}$$

$$v_{r_2} = \frac{v_2}{v_1} v_{r_2} = \frac{1}{r} v_{r_2} = \frac{1}{8} (144.32) = 18.04 \longrightarrow u_2 = 211.28 \text{ Btu/lbm}$$

Process 2-3: $v = \text{constant}$ heat addition.

$$T_3 = 2400\text{R} \longrightarrow \begin{aligned} u_3 &= 452.70 \text{ Btu/lbm} \\ v_{r_3} &= 2.419 \end{aligned}$$

$$q_{in} = u_3 - u_2 = 452.70 - 211.28 = \mathbf{241.42 \text{ Btu/lbm}}$$

(b) Process 3-4: isentropic expansion.

$$v_{r_4} = \frac{v_4}{v_3} v_{r_3} = r v_{r_3} = (8)(2.419) = 19.35 \longrightarrow u_4 = 205.54 \text{ Btu/lbm}$$

Process 4-1: $v = \text{constant}$ heat rejection.

$$q_{out} = u_4 - u_1 = 205.54 - 92.04 = 113.50 \text{ Btu/lbm}$$

$$\eta_{th} = 1 - \frac{q_{out}}{q_{in}} = 1 - \frac{113.50 \text{ Btu/lbm}}{241.42 \text{ Btu/lbm}} = \mathbf{53.0\%}$$

$$(c) \quad \eta_{th,C} = 1 - \frac{T_L}{T_H} = 1 - \frac{540 \text{ R}}{2400 \text{ R}} = \mathbf{77.5\%}$$

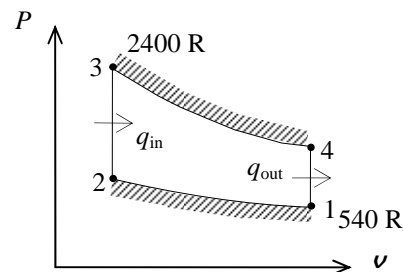

9-41E An ideal Otto cycle with argon as the working fluid has a compression ratio of 8. The amount of heat transferred to the argon during the heat addition process, the thermal efficiency, and the thermal efficiency of a Carnot cycle operating between the same temperature limits are to be determined.

Assumptions 1 The air-standard assumptions are applicable with argon as the working fluid. **2** Kinetic and potential energy changes are negligible. **3** Argon is an ideal gas with constant specific heats.

Properties The properties of argon are $c_p = 0.1253$ Btu/lbm.R, $c_v = 0.0756$ Btu/lbm.R, and $k = 1.667$ (Table A-2E).

Analysis (a) Process 1-2: isentropic compression.

$$T_2 = T_1 \left(\frac{v_1}{v_2} \right)^{k-1} = (540 \text{ R})(8)^{0.667} = 2161 \text{ R}$$

Process 2-3: $\nu = \text{constant}$ heat addition.

$$\begin{aligned} q_{\text{in}} &= u_3 - u_2 = c_v(T_3 - T_2) \\ &= (0.0756 \text{ Btu/lbm.R})(2400 - 2161) \text{ R} \\ &= \mathbf{18.07 \text{ Btu/lbm}} \end{aligned}$$

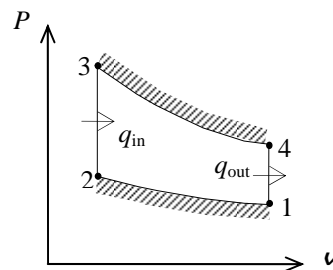

(b) Process 3-4: isentropic expansion.

$$T_4 = T_3 \left(\frac{v_3}{v_4} \right)^{k-1} = (2400 \text{ R}) \left(\frac{1}{8} \right)^{0.667} = 600 \text{ R}$$

Process 4-1: $\nu = \text{constant}$ heat rejection.

$$q_{\text{out}} = u_4 - u_1 = c_v(T_4 - T_1) = (0.0756 \text{ Btu/lbm.R})(600 - 540) \text{ R} = 4.536 \text{ Btu/lbm}$$

$$\eta_{\text{th}} = 1 - \frac{q_{\text{out}}}{q_{\text{in}}} = 1 - \frac{4.536 \text{ Btu/lbm}}{18.07 \text{ Btu/lbm}} = \mathbf{74.9\%}$$

$$(c) \quad \eta_{\text{th,C}} = 1 - \frac{T_L}{T_H} = 1 - \frac{540 \text{ R}}{2400 \text{ R}} = \mathbf{77.5\%}$$

9-42 A gasoline engine operates on an Otto cycle. The compression and expansion processes are modeled as polytropic. The temperature at the end of expansion process, the net work output, the thermal efficiency, the mean effective pressure, the engine speed for a given net power, and the specific fuel consumption are to be determined.

Assumptions 1 The air-standard assumptions are applicable. **2** Kinetic and potential energy changes are negligible. **3** Air is an ideal gas with constant specific heats.

Properties The properties of air at 850 K are $c_p = 1.110$ kJ/kg·K, $c_v = 0.823$ kJ/kg·K, $R = 0.287$ kJ/kg·K, and $k = 1.349$ (Table A-2b).

Analysis (a) Process 1-2: polytropic compression

$$T_2 = T_1 \left(\frac{v_1}{v_2} \right)^{n-1} = (333 \text{ K})(10)^{1.3-1} = 664.4 \text{ K}$$

$$P_2 = P_1 \left(\frac{v_1}{v_2} \right)^n = (100 \text{ kPa})(10)^{1.3} = 1995 \text{ kPa}$$

Process 2-3: constant volume heat addition

$$T_3 = T_2 \left(\frac{P_3}{P_2} \right) = (664.4 \text{ K}) \left(\frac{8000 \text{ kPa}}{1995 \text{ kPa}} \right) = 2664 \text{ K}$$

$$q_{\text{in}} = u_3 - u_2 = c_v(T_3 - T_2) \\ = (0.823 \text{ kJ/kg} \cdot \text{K})(2664 - 664.4) \text{ K} = 1646 \text{ kJ/kg}$$

Process 3-4: polytropic expansion.

$$T_4 = T_3 \left(\frac{v_3}{v_4} \right)^{n-1} = (2664 \text{ K}) \left(\frac{1}{10} \right)^{1.3-1} = 1335 \text{ K}$$

$$P_4 = P_3 \left(\frac{v_3}{v_4} \right)^n = (8000 \text{ kPa}) \left(\frac{1}{10} \right)^{1.3} = 400.9 \text{ kPa}$$

Process 4-1: constant volume heat rejection.

$$q_{\text{out}} = u_4 - u_1 = c_v(T_4 - T_1) = (0.823 \text{ kJ/kg} \cdot \text{K})(1335 - 333) \text{ K} = 824.8 \text{ kJ/kg}$$

(b) The net work output and the thermal efficiency are

$$w_{\text{net,out}} = q_{\text{in}} - q_{\text{out}} = 1646 - 824.8 = \mathbf{820.9 \text{ kJ/kg}}$$

$$\eta_{\text{th}} = \frac{w_{\text{net,out}}}{q_{\text{in}}} = \frac{820.9 \text{ kJ/kg}}{1646 \text{ kJ/kg}} = \mathbf{0.499}$$

(c) The mean effective pressure is determined as follows

$$v_1 = \frac{RT_1}{P_1} = \frac{(0.287 \text{ kPa} \cdot \text{m}^3/\text{kg} \cdot \text{K})(333 \text{ K})}{100 \text{ kPa}} = 0.9557 \text{ m}^3/\text{kg} = v_{\text{max}}$$

$$v_{\text{min}} = v_2 = \frac{v_{\text{max}}}{r}$$

$$\text{MEP} = \frac{w_{\text{net,out}}}{v_1 - v_2} = \frac{w_{\text{net,out}}}{v_1(1 - 1/r)} = \frac{820.9 \text{ kJ/kg}}{(0.9557 \text{ m}^3/\text{kg})(1 - 1/10)} \left(\frac{\text{kPa} \cdot \text{m}^3}{\text{kJ}} \right) = \mathbf{954.3 \text{ kPa}}$$

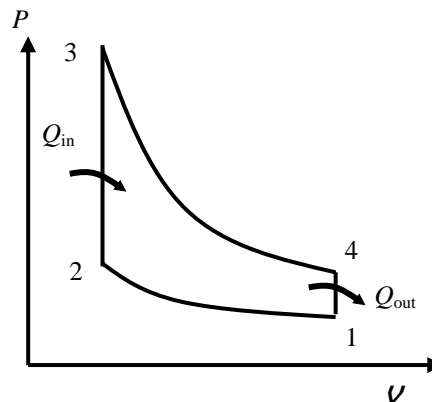

(d) The clearance volume and the total volume of the engine at the beginning of compression process (state 1) are

$$r = \frac{V_c + V_d}{V_c} \rightarrow 10 = \frac{V_c + 0.0022 \text{ m}^3}{V_c} \rightarrow V_c = 0.0002444 \text{ m}^3$$

$$V_1 = V_c + V_d = 0.0002444 + 0.0022 = 0.002444 \text{ m}^3$$

The total mass contained in the cylinder is

$$m_t = \frac{P_1 V_1}{RT_1} = \frac{(100 \text{ kPa})/0.002444 \text{ m}^3}{(0.287 \text{ kPa} \cdot \text{m}^3/\text{kg} \cdot \text{K})(333 \text{ K})} = 0.002558 \text{ kg}$$

The engine speed for a net power output of 70 kW is

$$\dot{n} = 2 \frac{\dot{W}_{\text{net}}}{m_t w_{\text{net}}} = (2 \text{ rev/cycle}) \frac{70 \text{ kJ/s}}{(0.002558 \text{ kg})(820.9 \text{ kJ/kg} \cdot \text{cycle})} \left(\frac{60 \text{ s}}{1 \text{ min}} \right) = \mathbf{4001 \text{ rev/min}}$$

Note that there are two revolutions in one cycle in four-stroke engines.

(e) The mass of fuel burned during one cycle is

$$\text{AF} = \frac{m_a}{m_f} = \frac{m_t - m_f}{m_f} \rightarrow 16 = \frac{(0.002558 \text{ kg}) - m_f}{m_f} \rightarrow m_f = 0.0001505 \text{ kg}$$

Finally, the specific fuel consumption is

$$\text{sfc} = \frac{m_f}{m_t w_{\text{net}}} = \frac{0.0001505 \text{ kg}}{(0.002558 \text{ kg})(820.9 \text{ kJ/kg})} \left(\frac{1000 \text{ g}}{1 \text{ kg}} \right) \left(\frac{3600 \text{ kJ}}{1 \text{ kWh}} \right) = \mathbf{258.0 \text{ g/kWh}}$$

9-43E The properties at various states of an ideal Otto cycle are given. The mean effective pressure is to be determined.

Assumptions 1 The air-standard assumptions are applicable. **2** Kinetic and potential energy changes are negligible. **3** Air is an ideal gas with constant specific heats.

Properties The properties of air at room temperature are $R = 0.3704 \text{ psia}\cdot\text{ft}^3/\text{lbm}\cdot\text{R}$ (Table A-1E), $c_p = 0.240 \text{ Btu}/\text{lbm}\cdot\text{R}$, $c_v = 0.171 \text{ Btu}/\text{lbm}\cdot\text{R}$, and $k = 1.4$ (Table A-2Ea).

Analysis At the end of the compression, the temperature is

$$T_2 = T_1 \left(\frac{v_1}{v_2} \right)^{k-1} = T_1 r^{k-1} = (520 \text{ R})(9)^{1.4-1} = 1252 \text{ R}$$

while the air temperature at the end of the expansion is

$$T_4 = T_3 \left(\frac{v_3}{v_4} \right)^{k-1} = T_3 \left(\frac{1}{r} \right)^{k-1} = (1960 \text{ R}) \left(\frac{1}{9} \right)^{1.4-1} = 813.9 \text{ R}$$

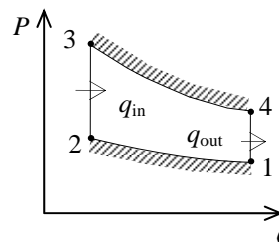

Application of the first law to the compression and expansion processes gives

$$\begin{aligned} w_{\text{net}} &= c_v(T_3 - T_4) - c_v(T_2 - T_1) \\ &= (0.171 \text{ Btu}/\text{lbm}\cdot\text{R})(1960 - 813.9)\text{R} - (0.171 \text{ Btu}/\text{lbm}\cdot\text{R})(1252 - 520)\text{R} \\ &= 70.81 \text{ Btu}/\text{lbm} \end{aligned}$$

At the beginning of the compression, the specific volume is

$$v_1 = \frac{RT_1}{P_1} = \frac{(0.3704 \text{ psia}\cdot\text{ft}^3/\text{lbm}\cdot\text{R})(520 \text{ R})}{14 \text{ psia}} = 13.76 \text{ ft}^3/\text{lbm}$$

while the specific volume at the end of the compression is

$$v_2 = \frac{v_1}{r} = \frac{13.76 \text{ ft}^3/\text{lbm}}{9} = 1.529 \text{ ft}^3/\text{lbm}$$

The engine's mean effective pressure is then

$$\text{MEP} = \frac{w_{\text{net}}}{v_1 - v_2} = \frac{70.81 \text{ Btu}/\text{lbm}}{(13.76 - 1.529) \text{ ft}^3/\text{lbm}} \left(\frac{5.404 \text{ psia}\cdot\text{ft}^3}{1 \text{ Btu}} \right) = \mathbf{31.3 \text{ psia}}$$

9-44E The power produced by an ideal Otto cycle is given. The rate of heat addition and rejection are to be determined.

Assumptions 1 The air-standard assumptions are applicable. **2** Kinetic and potential energy changes are negligible. **3** Air is an ideal gas with constant specific heats.

Properties The properties of air at room temperature are $R = 0.3704 \text{ psia}\cdot\text{ft}^3/\text{lbm}\cdot\text{R}$ (Table A-1E), $c_p = 0.240 \text{ Btu}/\text{lbm}\cdot\text{R}$, $c_v = 0.171 \text{ Btu}/\text{lbm}\cdot\text{R}$, and $k = 1.4$ (Table A-2Ea).

Analysis The thermal efficiency of the cycle is

$$\eta_{\text{th}} = 1 - \frac{1}{r^{k-1}} = 1 - \frac{1}{9^{1.4-1}} = 0.5848$$

According to the definition of the thermal efficiency, the rate of heat addition to this cycle is

$$\dot{Q}_{\text{in}} = \frac{\dot{W}_{\text{net}}}{\eta_{\text{th}}} = \frac{140 \text{ hp} \left(\frac{2544.5 \text{ Btu/h}}{1 \text{ hp}} \right)}{0.5848} = \mathbf{609,100 \text{ Btu/h}}$$

The rate of heat rejection is then

$$\dot{Q}_{\text{out}} = \dot{Q}_{\text{in}} - \dot{W}_{\text{net}} = 609,100 - (140 \times 2544.5 \text{ Btu/h}) = \mathbf{252,900 \text{ Btu/h}}$$

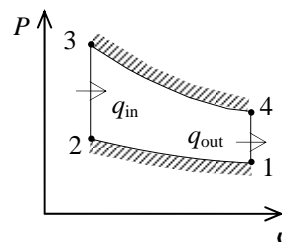

9-45 The expressions for the maximum gas temperature and pressure of an ideal Otto cycle are to be determined when the compression ratio is doubled.

Assumptions 1 The air-standard assumptions are applicable. **2** Kinetic and potential energy changes are negligible. **3** Air is an ideal gas with constant specific heats.

Analysis The temperature at the end of the compression varies with the compression ratio as

$$T_2 = T_1 \left(\frac{v_1}{v_2} \right)^{k-1} = T_1 r^{k-1}$$

since T_1 is fixed. The temperature rise during the combustion remains constant since the amount of heat addition is fixed. Then, the maximum cycle temperature is given by

$$T_3 = q_{\text{in}} + T_2 = q_{\text{in}} + T_1 r^{k-1}$$

The smallest gas specific volume during the cycle is

$$v_3 = \frac{v_1}{r}$$

When this is combined with the maximum temperature, the maximum pressure is given by

$$P_3 = \frac{RT_3}{v_3} = \frac{Rr}{v_1} (q_{\text{in}} + T_1 r^{k-1})$$

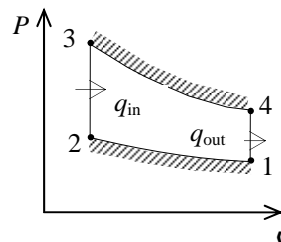

9-46 It is to be determined if the polytropic exponent to be used in an Otto cycle model will be greater than or less than the isentropic exponent.

Assumptions **1** The air-standard assumptions are applicable. **2** Kinetic and potential energy changes are negligible. **3** Air is an ideal gas with constant specific heats.

Analysis During a polytropic process,

$$Pv^n = \text{constant}$$

$$TP^{(n-1)/n} = \text{constant}$$

and for an isentropic process,

$$Pv^k = \text{constant}$$

$$TP^{(k-1)/k} = \text{constant}$$

If heat is lost during the expansion of the gas,

$$T_4 > T_{4s}$$

where T_{4s} is the temperature that would occur if the expansion were reversible and adiabatic ($n=k$). This can only occur when

$$n \leq k$$

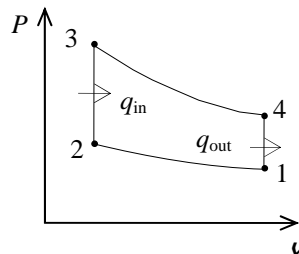

9-47 An ideal Otto cycle is considered. The heat rejection, the net work production, the thermal efficiency, and the mean effective pressure are to be determined.

Assumptions 1 The air-standard assumptions are applicable. **2** Kinetic and potential energy changes are negligible. **3** Air is an ideal gas with constant specific heats.

Properties The properties of air at room temperature are $R = 0.287 \text{ kJ/kg}\cdot\text{K}$, $c_p = 1.005 \text{ kJ/kg}\cdot\text{K}$, $c_v = 0.718 \text{ kJ/kg}\cdot\text{K}$, and $k = 1.4$ (Table A-2a).

Analysis The mass in this system is

$$m = \frac{P_1 V_1}{RT_1} = \frac{(90 \text{ kPa})(0.004 \text{ m}^3)}{(0.287 \text{ kPa}\cdot\text{m}^3/\text{kg}\cdot\text{K})(300 \text{ K})} = 0.004181 \text{ kg}$$

The two unknown temperatures are

$$T_2 = T_1 \left(\frac{v_1}{v_2} \right)^{k-1} = T_1 r^{k-1} = (300 \text{ K})(7)^{1.4-1} = 653.4 \text{ K}$$

$$T_4 = T_3 \left(\frac{v_3}{v_4} \right)^{k-1} = T_3 \left(\frac{1}{r} \right)^{k-1} = (1400 \text{ K}) \left(\frac{1}{7} \right)^{1.4-1} = 642.8 \text{ K}$$

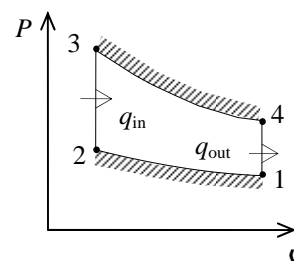

Application of the first law to four cycle processes gives

$$W_{1-2} = mc_v(T_2 - T_1) = (0.004181 \text{ kg})(0.718 \text{ kJ/kg}\cdot\text{K})(653.4 - 300)\text{K} = 1.061 \text{ kJ}$$

$$Q_{2-3} = mc_v(T_3 - T_2) = (0.004181 \text{ kg})(0.718 \text{ kJ/kg}\cdot\text{K})(1400 - 653.4)\text{K} = 2.241 \text{ kJ}$$

$$W_{3-4} = mc_v(T_3 - T_4) = (0.004181 \text{ kg})(0.718 \text{ kJ/kg}\cdot\text{K})(1400 - 642.8)\text{K} = 2.273 \text{ kJ}$$

$$Q_{4-1} = mc_v(T_4 - T_1) = (0.004181 \text{ kg})(0.718 \text{ kJ/kg}\cdot\text{K})(642.8 - 300)\text{K} = \mathbf{1.029 \text{ kJ}}$$

The net work is

$$W_{\text{net}} = W_{3-4} - W_{1-2} = 2.273 - 1.061 = \mathbf{1.212 \text{ kJ}}$$

The thermal efficiency is then

$$\eta_{\text{th}} = \frac{W_{\text{net}}}{Q_{\text{in}}} = \frac{1.212 \text{ kJ}}{2.241 \text{ kJ}} = \mathbf{0.541}$$

The minimum volume of the cycle occurs at the end of the compression

$$v_2 = \frac{v_1}{r} = \frac{0.004 \text{ m}^3}{7} = 0.0005714 \text{ m}^3$$

The engine's mean effective pressure is then

$$\text{MEP} = \frac{W_{\text{net}}}{v_1 - v_2} = \frac{1.212 \text{ kJ}}{(0.004 - 0.0005714) \text{ m}^3} \left(\frac{1 \text{ kPa}\cdot\text{m}^3}{1 \text{ kJ}} \right) = \mathbf{354 \text{ kPa}}$$

9-48 The power produced by an ideal Otto cycle is given. The rate of heat addition is to be determined.

Assumptions 1 The air-standard assumptions are applicable. **2** Kinetic and potential energy changes are negligible. **3** Air is an ideal gas with constant specific heats.

Properties The properties of air at room temperature are $R = 0.287 \text{ kPa}\cdot\text{m}^3/\text{kg}\cdot\text{K}$, $c_p = 1.005 \text{ kJ/kg}\cdot\text{K}$, $c_v = 0.718 \text{ kJ/kg}\cdot\text{K}$, and $k = 1.4$ (Table A-2a).

Analysis The compression ratio is

$$r = \frac{v_1}{v_2} = \frac{v_1}{0.15v_1} = 6.667$$

and the thermal efficiency is

$$\eta_{\text{th}} = 1 - \frac{1}{r^{k-1}} = 1 - \frac{1}{6.667^{1.4-1}} = 0.5318$$

The rate at which heat must be added to this engine is then

$$\dot{Q}_{\text{in}} = \frac{\dot{W}_{\text{net}}}{\eta_{\text{th}}} = \frac{90 \text{ hp}}{0.5318} \left(\frac{0.7457 \text{ kW}}{1 \text{ hp}} \right) = \mathbf{126.2 \text{ kW}}$$

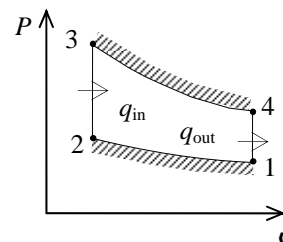

Diesel Cycle

9-49C A diesel engine differs from the gasoline engine in the way combustion is initiated. In diesel engines combustion is initiated by compressing the air above the self-ignition temperature of the fuel whereas it is initiated by a spark plug in a gasoline engine.

9-50C The Diesel cycle differs from the Otto cycle in the heat addition process only; it takes place at constant volume in the Otto cycle, but at constant pressure in the Diesel cycle.

9-51C The gasoline engine.

9-52C Diesel engines operate at high compression ratios because the diesel engines do not have the engine knock problem.

9-53C Cutoff ratio is the ratio of the cylinder volumes after and before the combustion process. As the cutoff ratio decreases, the efficiency of the diesel cycle increases.

9-54 An expression for cutoff ratio of an ideal diesel cycle is to be developed.

Assumptions 1 The air-standard assumptions are applicable. **2** Kinetic and potential energy changes are negligible. **3** Air is an ideal gas with constant specific heats.

Analysis Employing the isentropic process equations,

$$T_2 = T_1 r^{k-1}$$

while the ideal gas law gives

$$T_3 = T_2 r_c = r_c r^{k-1} T_1$$

When the first law and the closed system work integral is applied to the constant pressure heat addition, the result is

$$q_{\text{in}} = c_p (T_3 - T_2) = c_p (r_c r^{k-1} T_1 - r^{k-1} T_1)$$

When this is solved for cutoff ratio, the result is

$$r_c = 1 + \frac{q_{\text{in}}}{c_p r_c r^{k-1} T_1}$$

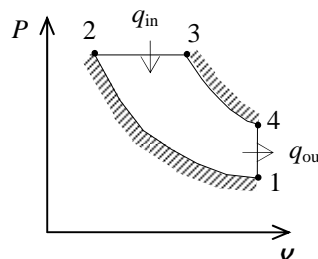

9-55 An ideal diesel cycle has a compression ratio of 18 and a cutoff ratio of 1.5. The maximum temperature of the air and the rate of heat addition are to be determined.

Assumptions **1** The air-standard assumptions are applicable. **2** Kinetic and potential energy changes are negligible. **3** Air is an ideal gas with constant specific heats.

Properties The properties of air at room temperature are $R = 0.287 \text{ kPa}\cdot\text{m}^3/\text{kg}\cdot\text{K}$, $c_p = 1.005 \text{ kJ/kg}\cdot\text{K}$, $c_v = 0.718 \text{ kJ/kg}\cdot\text{K}$, and $k = 1.4$ (Table A-2a).

Analysis We begin by using the process types to fix the temperatures of the states.

$$T_2 = T_1 \left(\frac{v_1}{v_2} \right)^{k-1} = T_1 r^{k-1} = (290 \text{ K})(18)^{1.4-1} = 921.5 \text{ K}$$

$$T_3 = T_2 \left(\frac{v_3}{v_2} \right) = T_2 r_c = (921.5 \text{ K})(1.5) = \mathbf{1382 \text{ K}}$$

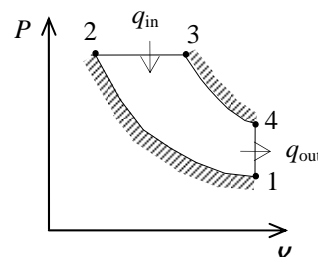

Combining the first law as applied to the various processes with the process equations gives

$$\eta_{\text{th}} = 1 - \frac{1}{r^{k-1}} \frac{r_c^k - 1}{k(r_c - 1)} = 1 - \frac{1}{18^{1.4-1}} \frac{1.5^{1.4} - 1}{1.4(1.5 - 1)} = 0.6565$$

According to the definition of the thermal efficiency,

$$\dot{Q}_{\text{in}} = \frac{\dot{W}_{\text{net}}}{\eta_{\text{th}}} = \frac{200 \text{ hp} \left(\frac{0.7457 \text{ kW}}{1 \text{ hp}} \right)}{0.6565} = \mathbf{227.2 \text{ kW}}$$

9-56 A Diesel cycle with non-isentropic compression and expansion processes is considered. The maximum temperature of the air and the rate of heat addition are to be determined.

Assumptions 1 The air-standard assumptions are applicable. **2** Kinetic and potential energy changes are negligible. **3** Air is an ideal gas with constant specific heats.

Properties The properties of air at room temperature are $R = 0.287 \text{ kPa}\cdot\text{m}^3/\text{kg}\cdot\text{K}$, $c_p = 1.005 \text{ kJ/kg}\cdot\text{K}$, $c_v = 0.718 \text{ kJ/kg}\cdot\text{K}$, and $k = 1.4$ (Table A-2a).

Analysis We begin by determining the temperatures of the cycle states using the process equations and component efficiencies. The ideal temperature at the end of the compression is then

$$T_{2s} = T_1 \left(\frac{v_1}{v_2} \right)^{k-1} = T_1 r^{k-1} = (290 \text{ K})(18)^{1.4-1} = 921.5 \text{ K}$$

With the isentropic compression efficiency, the actual temperature at the end of the compression is

$$\eta = \frac{T_{2s} - T_1}{T_2 - T_1} \longrightarrow T_2 = T_1 + \frac{T_{2s} - T_1}{\eta} = (290 \text{ K}) + \frac{(921.5 - 290) \text{ K}}{0.90} = 991.7 \text{ K}$$

The maximum temperature is

$$T_3 = T_2 \left(\frac{v_3}{v_2} \right) = T_2 r_c = (991.7 \text{ K})(1.5) = \mathbf{1488 \text{ K}}$$

For the isentropic expansion process,

$$T_{4s} = T_3 \left(\frac{v_3}{v_4} \right)^{k-1} = T_3 \left(\frac{r_c}{r} \right)^{k-1} = (1488 \text{ K}) \left(\frac{1.5}{18} \right)^{1.4-1} = 550.7 \text{ K}$$

since

$$\left. \begin{aligned} r_c &= \frac{v_3}{v_2} \\ r &= \frac{v_4}{v_2} \end{aligned} \right\} \frac{r_c}{r} = \frac{v_3 / v_2}{v_4 / v_2} = \frac{v_3}{v_4}$$

The actual temperature at the end of expansion process is then

$$\eta = \frac{T_3 - T_4}{T_3 - T_{4s}} \longrightarrow T_4 = T_3 - \eta(T_3 - T_{4s}) = (1488 \text{ K}) - (0.95)(1488 - 550.7) \text{ K} = 597.6 \text{ K}$$

The net work production is the difference between the work produced by the expansion and that used by the compression,

$$\begin{aligned} w_{\text{net}} &= c_v(T_3 - T_4) - c_v(T_2 - T_1) \\ &= (0.718 \text{ kJ/kg}\cdot\text{K})(1488 - 597.6) \text{ K} - (0.718 \text{ kJ/kg}\cdot\text{K})(991.7 - 290) \text{ K} \\ &= 135.5 \text{ kJ/kg} \end{aligned}$$

The heat addition occurs during process 2-3,

$$q_{\text{in}} = c_p(T_3 - T_2) = (1.005 \text{ kJ/kg}\cdot\text{K})(1488 - 991.7) \text{ K} = 498.8 \text{ kJ/kg}$$

The thermal efficiency of this cycle is then

$$\eta_{\text{th}} = \frac{w_{\text{net}}}{q_{\text{in}}} = \frac{135.5 \text{ kJ/kg}}{498.8 \text{ kJ/kg}} = 0.2717$$

According to the definition of the thermal efficiency,

$$\dot{Q}_{\text{in}} = \frac{\dot{W}_{\text{net}}}{\eta_{\text{th}}} = \frac{200 \text{ hp} \left(\frac{0.7457 \text{ kW}}{1 \text{ hp}} \right)}{0.2717} = \mathbf{548.9 \text{ kW}}$$

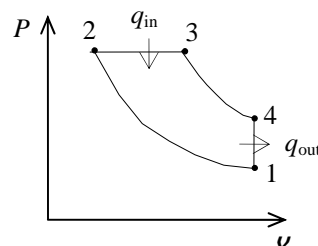

9-57 An ideal diesel cycle has a cutoff ratio of 1.2. The power produced is to be determined.

Assumptions 1 The air-standard assumptions are applicable. **2** Kinetic and potential energy changes are negligible. **3** Air is an ideal gas with constant specific heats.

Properties The properties of air at room temperature are $c_p = 1.005 \text{ kJ/kg}\cdot\text{K}$, $c_v = 0.718 \text{ kJ/kg}\cdot\text{K}$, $R = 0.287 \text{ kJ/kg}\cdot\text{K}$, and $k = 1.4$ (Table A-2a).

Analysis The specific volume of the air at the start of the compression is

$$v_1 = \frac{RT_1}{P_1} = \frac{(0.287 \text{ kPa}\cdot\text{m}^3/\text{kg}\cdot\text{K})(288 \text{ K})}{95 \text{ kPa}} = 0.8701 \text{ m}^3/\text{kg}$$

The total air mass taken by all 8 cylinders when they are charged is

$$m = N_{\text{cyl}} \frac{\Delta V}{v_1} = N_{\text{cyl}} \frac{\pi B^2 S / 4}{v_1} = (8) \frac{\pi(0.10 \text{ m})^2 (0.12 \text{ m})/4}{0.8701 \text{ m}^3/\text{kg}} = 0.008665 \text{ kg}$$

The rate at which air is processed by the engine is determined from

$$\dot{m} = \frac{m\dot{n}}{N_{\text{rev}}} = \frac{(0.008665 \text{ kg/cycle})(1600/60 \text{ rev/s})}{2 \text{ rev/cycle}} = 0.1155 \text{ kg/s}$$

since there are two revolutions per cycle in a four-stroke engine. The compression ratio is

$$r = \frac{1}{0.05} = 20$$

At the end of the compression, the air temperature is

$$T_2 = T_1 r^{k-1} = (288 \text{ K})(20)^{1.4-1} = 954.6 \text{ K}$$

Application of the first law and work integral to the constant pressure heat addition gives

$$q_{\text{in}} = c_p (T_3 - T_2) = (1.005 \text{ kJ/kg}\cdot\text{K})(2273 - 954.6) \text{ K} = 1325 \text{ kJ/kg}$$

while the thermal efficiency is

$$\eta_{\text{th}} = 1 - \frac{1}{r^{k-1}} \frac{r_c^k - 1}{k(r_c - 1)} = 1 - \frac{1}{20^{1.4-1}} \frac{1.2^{1.4} - 1}{1.4(1.2 - 1)} = 0.6867$$

The power produced by this engine is then

$$\begin{aligned} \dot{W}_{\text{net}} &= \dot{m} w_{\text{net}} = \dot{m} \eta_{\text{th}} q_{\text{in}} \\ &= (0.1155 \text{ kg/s})(0.6867)(1325 \text{ kJ/kg}) \\ &= \mathbf{105.1 \text{ kW}} \end{aligned}$$

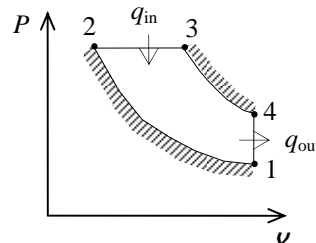

9-58E An ideal dual cycle has a compression ratio of 20 and cutoff ratio of 1.3. The thermal efficiency, amount of heat added, and the maximum gas pressure and temperature are to be determined.

Assumptions 1 The air-standard assumptions are applicable. **2** Kinetic and potential energy changes are negligible. **3** Air is an ideal gas with constant specific heats.

Properties The properties of air at room temperature are $R = 0.3704 \text{ psia}\cdot\text{ft}^3/\text{lbm}\cdot\text{R}$ (Table A-1E), $c_p = 0.240 \text{ Btu}/\text{lbm}\cdot\text{R}$, $c_v = 0.171 \text{ Btu}/\text{lbm}\cdot\text{R}$, and $k = 1.4$ (Table A-2Ea).

Analysis Working around the cycle, the germane properties at the various states are

$$T_2 = T_1 \left(\frac{v_1}{v_2} \right)^{k-1} = T_1 r^{k-1} = (530 \text{ R})(20)^{1.4-1} = 1757 \text{ R}$$

$$P_2 = P_1 \left(\frac{v_1}{v_2} \right)^k = P_1 r^k = (14 \text{ psia})(20)^{1.4} = 928 \text{ psia}$$

$$P_x = P_3 = r_p P_2 = (1.2)(928 \text{ psia}) = \mathbf{1114 \text{ psia}}$$

$$T_x = T_2 \left(\frac{P_x}{P_2} \right) = (1757 \text{ R}) \left(\frac{1114 \text{ psia}}{928 \text{ psia}} \right) = 2109 \text{ R}$$

$$T_3 = T_x \left(\frac{v_3}{v_x} \right) = T_x r_c = (2109 \text{ R})(1.3) = \mathbf{2742 \text{ R}}$$

$$T_4 = T_3 \left(\frac{v_3}{v_4} \right)^{k-1} = T_3 \left(\frac{r_c}{r} \right)^{k-1} = (2742 \text{ R}) \left(\frac{1.3}{20} \right)^{1.4-1} = 918.8 \text{ R}$$

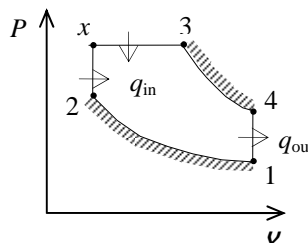

Applying the first law and work expression to the heat addition processes gives

$$\begin{aligned} q_{\text{in}} &= c_v(T_x - T_2) + c_p(T_3 - T_x) \\ &= (0.171 \text{ Btu}/\text{lbm}\cdot\text{R})(2109 - 1757)\text{R} + (0.240 \text{ Btu}/\text{lbm}\cdot\text{R})(2742 - 2109)\text{R} \\ &= \mathbf{212.1 \text{ Btu}/\text{lbm}} \end{aligned}$$

The heat rejected is

$$q_{\text{out}} = c_v(T_4 - T_1) = (0.171 \text{ Btu}/\text{lbm}\cdot\text{R})(918.8 - 530)\text{R} = 66.48 \text{ Btu}/\text{lbm}$$

Then,

$$\eta_{\text{th}} = 1 - \frac{q_{\text{out}}}{q_{\text{in}}} = 1 - \frac{66.48 \text{ Btu}/\text{lbm}}{212.1 \text{ Btu}/\text{lbm}} = \mathbf{0.687}$$

9-59E An ideal dual cycle has a compression ratio of 12 and cutoff ratio of 1.3. The thermal efficiency, amount of heat added, and the maximum gas pressure and temperature are to be determined.

Assumptions 1 The air-standard assumptions are applicable. **2** Kinetic and potential energy changes are negligible. **3** Air is an ideal gas with constant specific heats.

Properties The properties of air at room temperature are $R = 0.3704 \text{ psia}\cdot\text{ft}^3/\text{lbm}\cdot\text{R}$ (Table A-1E), $c_p = 0.240 \text{ Btu}/\text{lbm}\cdot\text{R}$, $c_v = 0.171 \text{ Btu}/\text{lbm}\cdot\text{R}$, and $k = 1.4$ (Table A-2Ea).

Analysis Working around the cycle, the germane properties at the various states are

$$T_2 = T_1 \left(\frac{v_1}{v_2} \right)^{k-1} = T_1 r^{k-1} = (530 \text{ R})(12)^{1.4-1} = 1432 \text{ R}$$

$$P_2 = P_1 \left(\frac{v_1}{v_2} \right)^k = P_1 r^k = (14 \text{ psia})(12)^{1.4} = 453.9 \text{ psia}$$

$$P_x = P_3 = r_p P_2 = (1.2)(453.9 \text{ psia}) = \mathbf{544.7 \text{ psia}}$$

$$T_x = T_2 \left(\frac{P_x}{P_2} \right) = (1432 \text{ R}) \left(\frac{544.7 \text{ psia}}{453.9 \text{ psia}} \right) = 1718 \text{ R}$$

$$T_3 = T_x \left(\frac{v_3}{v_x} \right) = T_x r_c = (1718 \text{ R})(1.3) = \mathbf{2233 \text{ R}}$$

$$T_4 = T_3 \left(\frac{v_3}{v_4} \right)^{k-1} = T_3 \left(\frac{r_c}{r} \right)^{k-1} = (2233 \text{ R}) \left(\frac{1.3}{12} \right)^{1.4-1} = 917.9 \text{ R}$$

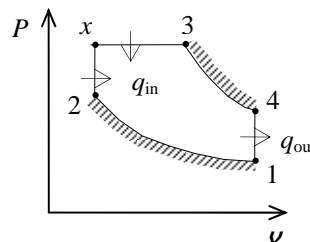

Applying the first law and work expression to the heat addition processes gives

$$\begin{aligned} q_{\text{in}} &= c_v(T_x - T_2) + c_p(T_3 - T_x) \\ &= (0.171 \text{ Btu}/\text{lbm}\cdot\text{R})(1718 - 1432)\text{R} + (0.240 \text{ Btu}/\text{lbm}\cdot\text{R})(2233 - 1718)\text{R} \\ &= \mathbf{172.5 \text{ Btu}/\text{lbm}} \end{aligned}$$

The heat rejected is

$$q_{\text{out}} = c_v(T_4 - T_1) = (0.171 \text{ Btu}/\text{lbm}\cdot\text{R})(917.9 - 530)\text{R} = 66.33 \text{ Btu}/\text{lbm}$$

Then,

$$\eta_{\text{th}} = 1 - \frac{q_{\text{out}}}{q_{\text{in}}} = 1 - \frac{66.33 \text{ Btu}/\text{lbm}}{172.5 \text{ Btu}/\text{lbm}} = \mathbf{0.615}$$

9-60E An air-standard Diesel cycle with a compression ratio of 18.2 is considered. The cutoff ratio, the heat rejection per unit mass, and the thermal efficiency are to be determined.

Assumptions 1 The air-standard assumptions are applicable. **2** Kinetic and potential energy changes are negligible. **3** Air is an ideal gas with variable specific heats.

Properties The properties of air are given in Table A-17E.

Analysis (a) Process 1-2: isentropic compression.

$$T_1 = 540 \text{ R} \longrightarrow \begin{matrix} u_1 = 92.04 \text{ Btu/lbm} \\ v_{r_1} = 144.32 \end{matrix}$$

$$v_{r_2} = \frac{v_2}{v_1} v_{r_1} = \frac{1}{r} v_{r_1} = \frac{1}{18.2} (144.32) = 7.93 \longrightarrow \begin{matrix} T_2 = 1623.6 \text{ R} \\ h_2 = 402.05 \text{ Btu/lbm} \end{matrix}$$

Process 2-3: $P = \text{constant}$ heat addition.

$$\frac{P_3 v_3}{T_3} = \frac{P_2 v_2}{T_2} \longrightarrow \frac{v_3}{v_2} = \frac{T_3}{T_2} = \frac{3000 \text{ R}}{1623.6 \text{ R}} = \mathbf{1.848}$$

$$(b) \quad T_3 = 3000 \text{ R} \longrightarrow \begin{matrix} h_3 = 790.68 \text{ Btu/lbm} \\ v_{r_3} = 1.180 \end{matrix}$$

$$q_{\text{in}} = h_3 - h_2 = 790.68 - 402.05 = 388.63 \text{ Btu/lbm}$$

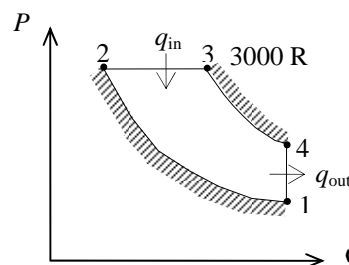

Process 3-4: isentropic expansion.

$$v_{r_4} = \frac{v_4}{v_3} v_{r_3} = \frac{v_4}{1.848 v_2} v_{r_3} = \frac{r}{1.848} v_{r_3} = \frac{18.2}{1.848} (1.180) = 11.621 \longrightarrow u_4 = 250.91 \text{ Btu/lbm}$$

Process 4-1: $v = \text{constant}$ heat rejection.

$$q_{\text{out}} = u_4 - u_1 = 250.91 - 92.04 = \mathbf{158.87 \text{ Btu/lbm}}$$

$$(c) \quad \eta_{\text{th}} = 1 - \frac{q_{\text{out}}}{q_{\text{in}}} = 1 - \frac{158.87 \text{ Btu/lbm}}{388.63 \text{ Btu/lbm}} = \mathbf{59.1\%}$$

9-61E An air-standard Diesel cycle with a compression ratio of 18.2 is considered. The cutoff ratio, the heat rejection per unit mass, and the thermal efficiency are to be determined.

Assumptions 1 The air-standard assumptions are applicable. **2** Kinetic and potential energy changes are negligible. **3** Air is an ideal gas with constant specific heats.

Properties The properties of air at room temperature are $c_p = 0.240$ Btu/lbm.R, $c_v = 0.171$ Btu/lbm.R, and $k = 1.4$ (Table A-2E).

Analysis (a) Process 1-2: isentropic compression.

$$T_2 = T_1 \left(\frac{v_1}{v_2} \right)^{k-1} = (540\text{R})(18.2)^{0.4} = 1724\text{R}$$

Process 2-3: $P = \text{constant}$ heat addition.

$$\frac{P_3 v_3}{T_3} = \frac{P_2 v_2}{T_2} \longrightarrow \frac{v_3}{v_2} = \frac{T_3}{T_2} = \frac{3000\text{R}}{1724\text{R}} = \mathbf{1.741}$$

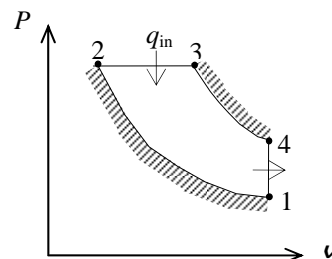

$$(b) \quad q_{\text{in}} = h_3 - h_2 = c_p (T_3 - T_2) = (0.240 \text{ Btu/lbm.R})(3000 - 1724)\text{R} = 306 \text{ Btu/lbm}$$

Process 3-4: isentropic expansion.

$$T_4 = T_3 \left(\frac{v_3}{v_4} \right)^{k-1} = T_3 \left(\frac{1.741 v_2}{v_4} \right)^{k-1} = (3000\text{R}) \left(\frac{1.741}{18.2} \right)^{0.4} = 1173\text{R}$$

Process 4-1: $v = \text{constant}$ heat rejection.

$$q_{\text{out}} = u_4 - u_1 = c_v (T_4 - T_1) \\ = (0.171 \text{ Btu/lbm.R})(1173 - 540)\text{R} = \mathbf{108 \text{ Btu/lbm}}$$

$$(c) \quad \eta_{\text{th}} = 1 - \frac{q_{\text{out}}}{q_{\text{in}}} = 1 - \frac{108 \text{ Btu/lbm}}{306 \text{ Btu/lbm}} = \mathbf{64.6\%}$$

9-62 An ideal diesel engine with air as the working fluid has a compression ratio of 20. The thermal efficiency and the mean effective pressure are to be determined.

Assumptions 1 The air-standard assumptions are applicable. **2** Kinetic and potential energy changes are negligible. **3** Air is an ideal gas with constant specific heats.

Properties The properties of air at room temperature are $c_p = 1.005 \text{ kJ/kg}\cdot\text{K}$, $c_v = 0.718 \text{ kJ/kg}\cdot\text{K}$, $R = 0.287 \text{ kJ/kg}\cdot\text{K}$, and $k = 1.4$ (Table A-2).

Analysis (a) Process 1-2: isentropic compression.

$$T_2 = T_1 \left(\frac{v_1}{v_2} \right)^{k-1} = (293 \text{ K})(20)^{0.4} = 971.1 \text{ K}$$

Process 2-3: $P = \text{constant}$ heat addition.

$$\frac{P_3 v_3}{T_3} = \frac{P_2 v_2}{T_2} \longrightarrow \frac{v_3}{v_2} = \frac{T_3}{T_2} = \frac{2200 \text{ K}}{971.1 \text{ K}} = 2.265$$

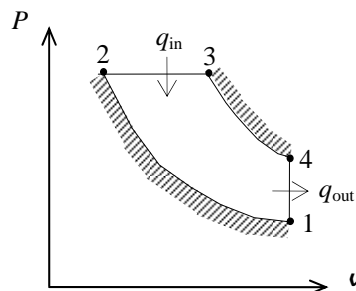

Process 3-4: isentropic expansion.

$$T_4 = T_3 \left(\frac{v_3}{v_4} \right)^{k-1} = T_3 \left(\frac{2.265 v_2}{v_4} \right)^{k-1} = T_3 \left(\frac{2.265}{r} \right)^{k-1} = (2200 \text{ K}) \left(\frac{2.265}{20} \right)^{0.4} = 920.6 \text{ K}$$

$$q_{\text{in}} = h_3 - h_2 = c_p (T_3 - T_2) = (1.005 \text{ kJ/kg}\cdot\text{K})(2200 - 971.1) \text{ K} = 1235 \text{ kJ/kg}$$

$$q_{\text{out}} = u_4 - u_1 = c_v (T_4 - T_1) = (0.718 \text{ kJ/kg}\cdot\text{K})(920.6 - 293) \text{ K} = 450.6 \text{ kJ/kg}$$

$$w_{\text{net,out}} = q_{\text{in}} - q_{\text{out}} = 1235 - 450.6 = 784.4 \text{ kJ/kg}$$

$$\eta_{\text{th}} = \frac{w_{\text{net,out}}}{q_{\text{in}}} = \frac{784.4 \text{ kJ/kg}}{1235 \text{ kJ/kg}} = \mathbf{63.5\%}$$

$$(b) \quad v_1 = \frac{RT_1}{P_1} = \frac{(0.287 \text{ kPa}\cdot\text{m}^3/\text{kg}\cdot\text{K})(293 \text{ K})}{95 \text{ kPa}} = 0.885 \text{ m}^3/\text{kg} = v_{\text{max}}$$

$$v_{\text{min}} = v_2 = \frac{v_{\text{max}}}{r}$$

$$\text{MEP} = \frac{w_{\text{net,out}}}{v_1 - v_2} = \frac{w_{\text{net,out}}}{v_1 (1 - 1/r)} = \frac{784.4 \text{ kJ/kg}}{(0.885 \text{ m}^3/\text{kg})(1 - 1/20)} \left(\frac{\text{kPa}\cdot\text{m}^3}{\text{kJ}} \right) = \mathbf{933 \text{ kPa}}$$

9-63 A diesel engine with air as the working fluid has a compression ratio of 20. The thermal efficiency and the mean effective pressure are to be determined.

Assumptions 1 The air-standard assumptions are applicable. **2** Kinetic and potential energy changes are negligible. **3** Air is an ideal gas with constant specific heats.

Properties The properties of air at room temperature are $c_p = 1.005 \text{ kJ/kg}\cdot\text{K}$, $c_v = 0.718 \text{ kJ/kg}\cdot\text{K}$, and $k = 1.4$ (Table A-2).

Analysis (a) Process 1-2: isentropic compression.

$$T_2 = T_1 \left(\frac{v_1}{v_2} \right)^{k-1} = (293 \text{ K})(20)^{0.4} = 971.1 \text{ K}$$

Process 2-3: $P = \text{constant}$ heat addition.

$$\frac{P_3 v_3}{T_3} = \frac{P_2 v_2}{T_2} \longrightarrow \frac{v_3}{v_2} = \frac{T_3}{T_2} = \frac{2200 \text{ K}}{971.1 \text{ K}} = 2.265$$

Process 3-4: polytropic expansion.

$$T_4 = T_3 \left(\frac{v_3}{v_4} \right)^{n-1} = T_3 \left(\frac{2.265 v_2}{v_4} \right)^{n-1} = T_3 \left(\frac{2.265}{r} \right)^{n-1} = (2200 \text{ K}) \left(\frac{2.265}{20} \right)^{0.35} = 1026 \text{ K}$$

$$q_{\text{in}} = h_3 - h_2 = c_p (T_3 - T_2) = (1.005 \text{ kJ/kg}\cdot\text{K})(2200 - 971.1) \text{ K} = 1235 \text{ kJ/kg}$$

$$q_{\text{out}} = u_4 - u_1 = c_v (T_4 - T_1) = (0.718 \text{ kJ/kg}\cdot\text{K})(1026 - 293) \text{ K} = 526.3 \text{ kJ/kg}$$

Note that q_{out} in this case does not represent the entire heat rejected since some heat is also rejected during the polytropic process, which is determined from an energy balance on process 3-4:

$$w_{34,\text{out}} = \frac{R(T_4 - T_3)}{1-n} = \frac{(0.287 \text{ kJ/kg}\cdot\text{K})(1026 - 2200) \text{ K}}{1-1.35} = 963 \text{ kJ/kg}$$

$$E_{\text{in}} - E_{\text{out}} = \Delta E_{\text{system}}$$

$$\begin{aligned} q_{34,\text{in}} - w_{34,\text{out}} &= u_4 - u_3 \longrightarrow q_{34,\text{in}} = w_{34,\text{out}} + c_v (T_4 - T_3) \\ &= 963 \text{ kJ/kg} + (0.718 \text{ kJ/kg}\cdot\text{K})(1026 - 2200) \text{ K} \\ &= 120.1 \text{ kJ/kg} \end{aligned}$$

which means that 120.1 kJ/kg of heat is transferred to the combustion gases during the expansion process. This is unrealistic since the gas is at a much higher temperature than the surroundings, and a hot gas loses heat during polytropic expansion. The cause of this unrealistic result is the constant specific heat assumption. If we were to use u data from the air table, we would obtain

$$q_{34,\text{in}} = w_{34,\text{out}} + (u_4 - u_3) = 963 + (781.3 - 1872.4) = -128.1 \text{ kJ/kg}$$

which is a heat loss as expected. Then q_{out} becomes

$$q_{\text{out}} = q_{34,\text{out}} + q_{41,\text{out}} = 128.1 + 526.3 = 654.4 \text{ kJ/kg}$$

and

$$w_{\text{net,out}} = q_{\text{in}} - q_{\text{out}} = 1235 - 654.4 = 580.6 \text{ kJ/kg}$$

$$\eta_{\text{th}} = \frac{w_{\text{net,out}}}{q_{\text{in}}} = \frac{580.6 \text{ kJ/kg}}{1235 \text{ kJ/kg}} = \mathbf{47.0\%}$$

$$(b) \quad v_1 = \frac{RT_1}{P_1} = \frac{(0.287 \text{ kPa}\cdot\text{m}^3/\text{kg}\cdot\text{K})(293 \text{ K})}{95 \text{ kPa}} = 0.885 \text{ m}^3/\text{kg} = v_{\text{max}}$$

$$v_{\text{min}} = v_2 = \frac{v_{\text{max}}}{r}$$

$$\text{MEP} = \frac{w_{\text{net,out}}}{v_1 - v_2} = \frac{w_{\text{net,out}}}{v_1 (1 - 1/r)} = \frac{580.6 \text{ kJ/kg}}{(0.885 \text{ m}^3/\text{kg})(1 - 1/20)} \left(\frac{1 \text{ kPa}\cdot\text{m}^3}{\text{kJ}} \right) = \mathbf{691 \text{ kPa}}$$

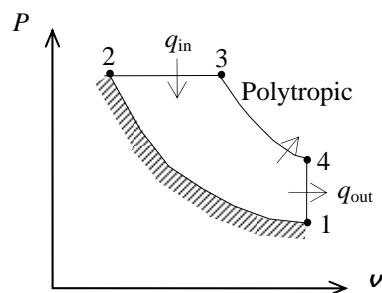

9-64 EES Problem 9-63 is reconsidered. The effect of the compression ratio on the net work output, mean effective pressure, and thermal efficiency is to be investigated. Also, T - s and P - v diagrams for the cycle are to be plotted.

Analysis Using EES, the problem is solved as follows:

Procedure QTotal(q_12,q_23,q_34,q_41: q_in_total,q_out_total)

q_in_total = 0

q_out_total = 0

IF (q_12 > 0) THEN q_in_total = q_12 ELSE q_out_total = - q_12

If q_23 > 0 then q_in_total = q_in_total + q_23 else q_out_total = q_out_total - q_23

If q_34 > 0 then q_in_total = q_in_total + q_34 else q_out_total = q_out_total - q_34

If q_41 > 0 then q_in_total = q_in_total + q_41 else q_out_total = q_out_total - q_41

END

"Input Data"

T[1]=293 [K]

P[1]=95 [kPa]

T[3] = 2200 [K]

n=1.35

{r_comp = 20}

"Process 1-2 is isentropic compression"

s[1]=entropy(air,T=T[1],P=P[1])

s[2]=s[1]

T[2]=temperature(air, s=s[2], P=P[2])

P[2]*v[2]/T[2]=P[1]*v[1]/T[1]

P[1]*v[1]=R*T[1]

R=0.287 [kJ/kg-K]

V[2] = V[1]/ r_comp

"Conservation of energy for process 1 to 2"

q_12 - w_12 = DELTAu_12

q_12 = 0 "isentropic process"

DELTAu_12=intenergy(air,T=T[2])-intenergy(air,T=T[1])

"Process 2-3 is constant pressure heat addition"

P[3]=P[2]

s[3]=entropy(air, T=T[3], P=P[3])

P[3]*v[3]=R*T[3]

"Conservation of energy for process 2 to 3"

q_23 - w_23 = DELTAu_23

w_23 =P[2]*(V[3] - V[2]) "constant pressure process"

DELTAu_23=intenergy(air,T=T[3])-intenergy(air,T=T[2])

"Process 3-4 is polytropic expansion"

P[3]/P[4] =(V[4]/V[3])^n

s[4]=entropy(air,T=T[4],P=P[4])

P[4]*v[4]=R*T[4]

"Conservation of energy for process 3 to 4"

q_34 - w_34 = DELTAu_34 "q_34 is not 0 for the ploytropic process"

DELTAu_34=intenergy(air,T=T[4])-intenergy(air,T=T[3])

P[3]*V[3]^n = Const

w_34=(P[4]*V[4]-P[3]*V[3])/(1-n)

"Process 4-1 is constant volume heat rejection"

V[4] = V[1]

"Conservation of energy for process 4 to 1"

q_41 - w_41 = DELTAu_41

w_41 = 0 "constant volume process"

$$\text{DELTA}u_{41} = \text{intenergy}(\text{air}, T=T[1]) - \text{intenergy}(\text{air}, T=T[4])$$

Call QTotal(q_12,q_23,q_34,q_41: q_in_total,q_out_total)

$$w_{\text{net}} = w_{12} + w_{23} + w_{34} + w_{41}$$

$$\eta_{\text{th}} = w_{\text{net}} / q_{\text{in_total}} * 100 \text{ "Thermal efficiency, in percent"}$$

"The mean effective pressure is:"

$$\text{MEP} = w_{\text{net}} / (V[1] - V[2])$$

r_{comp}	η_{th}	MEP [kPa]	w_{net} [kJ/kg]
14	47.69	970.8	797.9
16	50.14	985	817.4
18	52.16	992.6	829.8
20	53.85	995.4	837.0
22	55.29	994.9	840.6
24	56.54	992	841.5

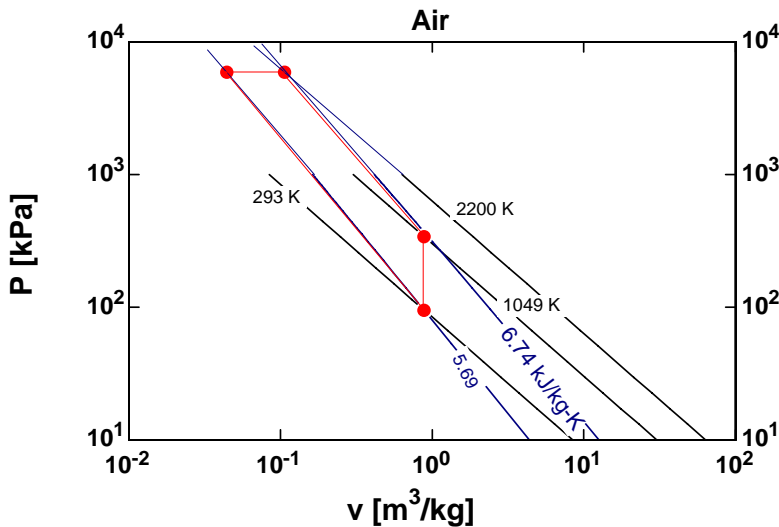
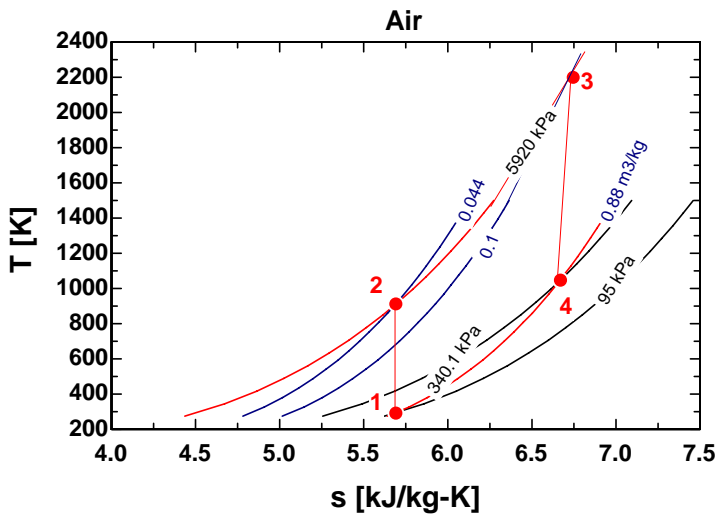

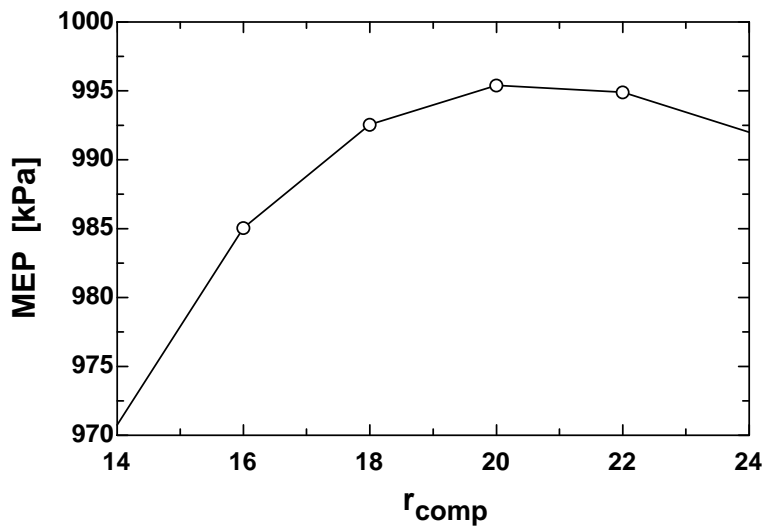
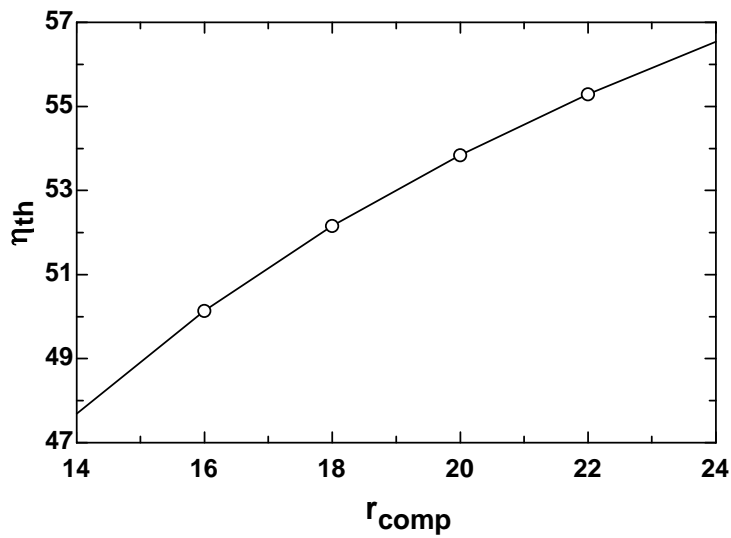
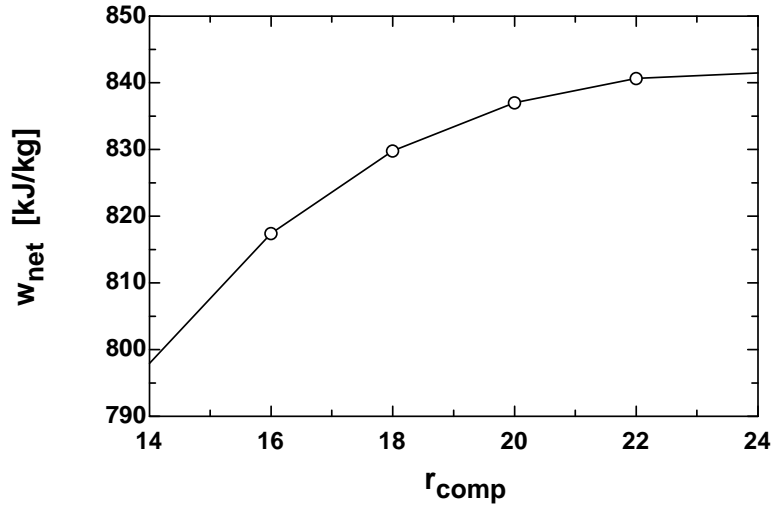

9-65 A four-cylinder ideal diesel engine with air as the working fluid has a compression ratio of 17 and a cutoff ratio of 2.2. The power the engine will deliver at 1500 rpm is to be determined.

Assumptions 1 The cold air-standard assumptions are applicable. **2** Kinetic and potential energy changes are negligible. **3** Air is an ideal gas with constant specific heats.

Properties The properties of air at room temperature are $c_p = 1.005 \text{ kJ/kg}\cdot\text{K}$, $c_v = 0.718 \text{ kJ/kg}\cdot\text{K}$, $R = 0.287 \text{ kJ/kg}\cdot\text{K}$, and $k = 1.4$ (Table A-2).

Analysis Process 1-2: isentropic compression.

$$T_2 = T_1 \left(\frac{v_1}{v_2} \right)^{k-1} = (328 \text{ K})(17)^{0.4} = 1019 \text{ K}$$

Process 2-3: $P = \text{constant}$ heat addition.

$$\frac{P_3 v_3}{T_3} = \frac{P_2 v_2}{T_2} \longrightarrow T_3 = \frac{v_3}{v_2} T_2 = 2.2 T_2 = (2.2)(1019 \text{ K}) = 2241 \text{ K}$$

Process 3-4: isentropic expansion.

$$T_4 = T_3 \left(\frac{v_3}{v_4} \right)^{k-1} = T_3 \left(\frac{2.2 v_2}{v_4} \right)^{k-1} = T_3 \left(\frac{2.2}{r} \right)^{k-1} = (2241 \text{ K}) \left(\frac{2.2}{17} \right)^{0.4} = 989.2 \text{ K}$$

$$m = \frac{P_1 v_1}{RT_1} = \frac{(97 \text{ kPa})(0.0024 \text{ m}^3)}{(0.287 \text{ kPa}\cdot\text{m}^3/\text{kg}\cdot\text{K})(328 \text{ K})} = 2.473 \times 10^{-3} \text{ kg}$$

$$\begin{aligned} Q_{\text{in}} &= m(h_3 - h_2) = mc_p(T_3 - T_2) \\ &= (2.473 \times 10^{-3} \text{ kg})(1.005 \text{ kJ/kg}\cdot\text{K})(2241 - 1019) \text{ K} = 3.038 \text{ kJ} \end{aligned}$$

$$\begin{aligned} Q_{\text{out}} &= m(u_4 - u_1) = mc_v(T_4 - T_1) \\ &= (2.473 \times 10^{-3} \text{ kg})(0.718 \text{ kJ/kg}\cdot\text{K})(989.2 - 328) \text{ K} = 1.174 \text{ kJ} \end{aligned}$$

$$W_{\text{net,out}} = Q_{\text{in}} - Q_{\text{out}} = 3.038 - 1.174 = 1.864 \text{ kJ/rev}$$

$$\dot{W}_{\text{net,out}} = \dot{n} W_{\text{net,out}} = (1500/60 \text{ rev/s})(1.864 \text{ kJ/rev}) = \mathbf{46.6 \text{ kW}}$$

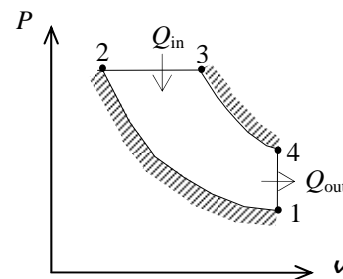

Discussion Note that for 2-stroke engines, 1 thermodynamic cycle is equivalent to 1 mechanical cycle (and thus revolutions).

9-66 A four-cylinder ideal diesel engine with nitrogen as the working fluid has a compression ratio of 17 and a cutoff ratio of 2.2. The power the engine will deliver at 1500 rpm is to be determined.

Assumptions 1 The air-standard assumptions are applicable with nitrogen as the working fluid. **2** Kinetic and potential energy changes are negligible. **3** Nitrogen is an ideal gas with constant specific heats.

Properties The properties of nitrogen at room temperature are $c_p = 1.039 \text{ kJ/kg}\cdot\text{K}$, $c_v = 0.743 \text{ kJ/kg}\cdot\text{K}$, $R = 0.2968 \text{ kJ/kg}\cdot\text{K}$, and $k = 1.4$ (Table A-2).

Analysis Process 1-2: isentropic compression.

$$T_2 = T_1 \left(\frac{v_1}{v_2} \right)^{k-1} = (328 \text{ K})(17)^{0.4} = 1019 \text{ K}$$

Process 2-3: $P = \text{constant}$ heat addition.

$$\frac{P_3 v_3}{T_3} = \frac{P_2 v_2}{T_2} \longrightarrow T_3 = \frac{v_3}{v_2} T_2 = 2.2 T_2 = (2.2)(1019 \text{ K}) = 2241 \text{ K}$$

Process 3-4: isentropic expansion.

$$T_4 = T_3 \left(\frac{v_3}{v_4} \right)^{k-1} = T_3 \left(\frac{2.2 v_2}{v_4} \right)^{k-1} = T_3 \left(\frac{2.2}{r} \right)^{k-1} = (2241 \text{ K}) \left(\frac{2.2}{17} \right)^{0.4} = 989.2 \text{ K}$$

$$m = \frac{P_1 v_1}{RT_1} = \frac{(97 \text{ kPa})(0.0024 \text{ m}^3)}{(0.2968 \text{ kPa}\cdot\text{m}^3/\text{kg}\cdot\text{K})(328 \text{ K})} = 2.391 \times 10^{-3} \text{ kg}$$

$$\begin{aligned} Q_{\text{in}} &= m(h_3 - h_2) = mc_p(T_3 - T_2) \\ &= (2.391 \times 10^{-3} \text{ kg})(1.039 \text{ kJ/kg}\cdot\text{K})(2241 - 1019) \text{ K} = 3.037 \text{ kJ} \end{aligned}$$

$$\begin{aligned} Q_{\text{out}} &= m(u_4 - u_1) = mc_v(T_4 - T_1) \\ &= (2.391 \times 10^{-3} \text{ kg})(0.743 \text{ kJ/kg}\cdot\text{K})(989.2 - 328) \text{ K} = 1.175 \text{ kJ} \end{aligned}$$

$$W_{\text{net,out}} = Q_{\text{in}} - Q_{\text{out}} = 3.037 - 1.175 = 1.863 \text{ kJ/rev}$$

$$\dot{W}_{\text{net,out}} = \dot{n} W_{\text{net,out}} = (1500/60 \text{ rev/s})(1.863 \text{ kJ/rev}) = \mathbf{46.6 \text{ kW}}$$

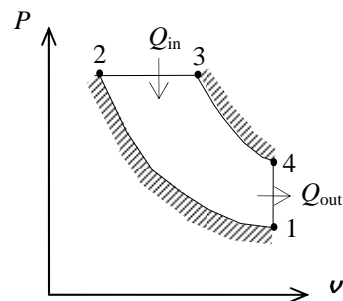

Discussion Note that for 2-stroke engines, 1 thermodynamic cycle is equivalent to 1 mechanical cycle (and thus revolutions).

9-67 An ideal dual cycle has a compression ratio of 18 and cutoff ratio of 1.1. The power produced by the cycle is to be determined.

Assumptions 1 The air-standard assumptions are applicable. **2** Kinetic and potential energy changes are negligible. **3** Air is an ideal gas with constant specific heats.

Properties The properties of air at room temperature are $c_p = 1.005 \text{ kJ/kg}\cdot\text{K}$, $c_v = 0.718 \text{ kJ/kg}\cdot\text{K}$, $R = 0.287 \text{ kJ/kg}\cdot\text{K}$, and $k = 1.4$ (Table A-2a).

Analysis We begin by fixing the temperatures at all states.

$$T_2 = T_1 \left(\frac{v_1}{v_2} \right)^{k-1} = T_1 r^{k-1} = (291 \text{ K})(18)^{1.4-1} = 924.7 \text{ K}$$

$$P_2 = P_1 \left(\frac{v_1}{v_2} \right)^k = P_1 r^k = (90 \text{ kPa})(18)^{1.4} = 5148 \text{ kPa}$$

$$P_x = P_3 = r_p P_2 = (1.1)(5148 \text{ kPa}) = 5663 \text{ kPa}$$

$$T_x = T_2 \left(\frac{P_x}{P_2} \right) = (924.7 \text{ K}) \left(\frac{5663 \text{ kPa}}{5148 \text{ kPa}} \right) = 1017 \text{ K}$$

$$T_3 = r_c T_x = (1.1)(1017 \text{ K}) = 1119 \text{ K}$$

$$T_4 = T_3 \left(\frac{v_3}{v_4} \right)^{k-1} = T_3 \left(\frac{r_c}{r} \right)^{k-1} = (1119 \text{ K}) \left(\frac{1.1}{18} \right)^{1.4-1} = 365.8 \text{ K}$$

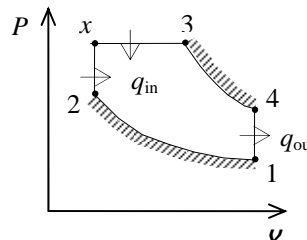

Applying the first law to each of the processes gives

$$w_{1-2} = c_v(T_2 - T_1) = (0.718 \text{ kJ/kg}\cdot\text{K})(924.7 - 291)\text{K} = 455.0 \text{ kJ/kg}$$

$$q_{x-3} = c_p(T_3 - T_x) = (1.005 \text{ kJ/kg}\cdot\text{K})(1119 - 1017)\text{K} = 102.5 \text{ kJ/kg}$$

$$w_{x-3} = q_{x-3} - c_v(T_3 - T_x) = 102.5 - (0.718 \text{ kJ/kg}\cdot\text{K})(1119 - 1017)\text{K} = 29.26 \text{ kJ/kg}$$

$$w_{3-4} = c_v(T_3 - T_4) = (0.718 \text{ kJ/kg}\cdot\text{K})(1119 - 365.8)\text{K} = 540.8 \text{ kJ/kg}$$

The net work of the cycle is

$$w_{\text{net}} = w_{3-4} + w_{x-3} - w_{1-2} = 540.8 + 29.26 - 455.0 = 115.1 \text{ kJ/kg}$$

The mass in the device is given by

$$m = \frac{P_1 V_1}{RT_1} = \frac{(90 \text{ kPa})(0.003 \text{ m}^3)}{(0.287 \text{ kPa}\cdot\text{m}^3/\text{kg}\cdot\text{K})(291 \text{ K})} = 0.003233 \text{ kg}$$

The net power produced by this engine is then

$$\dot{W}_{\text{net}} = m w_{\text{net}} \dot{n} = (0.003233 \text{ kg/cycle})(115.1 \text{ kJ/kg})(4000/60 \text{ cycle/s}) = \mathbf{24.8 \text{ kW}}$$

9-68 A dual cycle with non-isentropic compression and expansion processes is considered. The power produced by the cycle is to be determined.

Assumptions 1 The air-standard assumptions are applicable. **2** Kinetic and potential energy changes are negligible. **3** Air is an ideal gas with constant specific heats.

Properties The properties of air at room temperature are $c_p = 1.005 \text{ kJ/kg}\cdot\text{K}$, $c_v = 0.718 \text{ kJ/kg}\cdot\text{K}$, $R = 0.287 \text{ kJ/kg}\cdot\text{K}$, and $k = 1.4$ (Table A-2a).

Analysis We begin by fixing the temperatures at all states.

$$T_{2s} = T_1 \left(\frac{v_1}{v_2} \right)^{k-1} = T_1 r^{k-1} = (291 \text{ K})(18)^{1.4-1} = 924.7 \text{ K}$$

$$\eta = \frac{T_{2s} - T_1}{T_2 - T_1} \longrightarrow T_2 = T_1 + \frac{T_{2s} - T_1}{\eta} = (291 \text{ K}) + \frac{(924.7 - 291) \text{ K}}{0.85} = 1037 \text{ K}$$

$$P_2 = P_1 \left(\frac{v_1}{v_2} \right)^k = P_1 r^k = (90 \text{ kPa})(18)^{1.4} = 5148 \text{ kPa}$$

$$P_x = P_3 = r_p P_2 = (1.1)(5148 \text{ kPa}) = 5663 \text{ kPa}$$

$$T_x = T_2 \left(\frac{P_x}{P_2} \right) = (1037 \text{ K}) \left(\frac{5663 \text{ kPa}}{5148 \text{ kPa}} \right) = 1141 \text{ K}$$

$$T_3 = r_c T_x = (1.1)(1141 \text{ K}) = 1255 \text{ K}$$

$$T_{4s} = T_3 \left(\frac{v_3}{v_4} \right)^{k-1} = T_3 \left(\frac{r_c}{r} \right)^{k-1} = (1255 \text{ K}) \left(\frac{1.1}{18} \right)^{1.4-1} = 410.3 \text{ K}$$

$$\eta = \frac{T_3 - T_4}{T_3 - T_{4s}} \longrightarrow T_4 = T_3 - \eta(T_3 - T_{4s}) = (1255 \text{ K}) - (0.90)(1255 - 410.3) \text{ K} = 494.8 \text{ K}$$

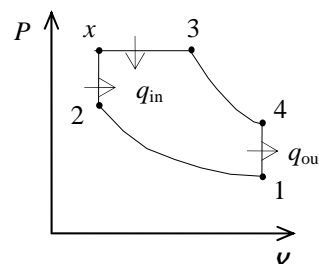

Applying the first law to each of the processes gives

$$w_{1-2} = c_v(T_2 - T_1) = (0.718 \text{ kJ/kg}\cdot\text{K})(1037 - 291) \text{ K} = 535.6 \text{ kJ/kg}$$

$$q_{x-3} = c_p(T_3 - T_x) = (1.005 \text{ kJ/kg}\cdot\text{K})(1255 - 1141) \text{ K} = 114.6 \text{ kJ/kg}$$

$$w_{x-3} = q_{x-3} - c_v(T_3 - T_x) = 114.6 - (0.718 \text{ kJ/kg}\cdot\text{K})(1255 - 1141) \text{ K} = 32.75 \text{ kJ/kg}$$

$$w_{3-4} = c_v(T_3 - T_4) = (0.718 \text{ kJ/kg}\cdot\text{K})(1255 - 494.8) \text{ K} = 545.8 \text{ kJ/kg}$$

The net work of the cycle is

$$w_{\text{net}} = w_{3-4} + w_{x-3} - w_{1-2} = 545.8 + 32.75 - 535.6 = 42.95 \text{ kJ/kg}$$

The mass in the device is given by

$$m = \frac{P_1 V_1}{RT_1} = \frac{(90 \text{ kPa})(0.003 \text{ m}^3)}{(0.287 \text{ kPa}\cdot\text{m}^3/\text{kg}\cdot\text{K})(291 \text{ K})} = 0.003233 \text{ kg}$$

The net power produced by this engine is then

$$\dot{W}_{\text{net}} = m w_{\text{net}} \dot{n} = (0.003233 \text{ kg/cycle})(42.95 \text{ kJ/kg})(4000/60 \text{ cycle/s}) = \mathbf{9.26 \text{ kW}}$$

9-69E An ideal dual cycle has a compression ratio of 15 and cutoff ratio of 1.4. The net work, heat addition, and the thermal efficiency are to be determined.

Assumptions 1 The air-standard assumptions are applicable. **2** Kinetic and potential energy changes are negligible. **3** Air is an ideal gas with constant specific heats.

Properties The properties of air at room temperature are $R = 0.3704 \text{ psia}\cdot\text{ft}^3/\text{lbm}\cdot\text{R}$ (Table A-1E), $c_p = 0.240 \text{ Btu}/\text{lbm}\cdot\text{R}$, $c_v = 0.171 \text{ Btu}/\text{lbm}\cdot\text{R}$, and $k = 1.4$ (Table A-2Ea).

Analysis Working around the cycle, the germane properties at the various states are

$$T_2 = T_1 \left(\frac{v_1}{v_2} \right)^{k-1} = T_1 r^{k-1} = (535 \text{ R})(15)^{1.4-1} = 1580 \text{ R}$$

$$P_2 = P_1 \left(\frac{v_1}{v_2} \right)^k = P_1 r^k = (14.2 \text{ psia})(15)^{1.4} = 629.2 \text{ psia}$$

$$P_x = P_3 = r_p P_2 = (1.1)(629.2 \text{ psia}) = 692.1 \text{ psia}$$

$$T_x = T_2 \left(\frac{P_x}{P_2} \right) = (1580 \text{ R}) \left(\frac{692.1 \text{ psia}}{629.2 \text{ psia}} \right) = 1738 \text{ R}$$

$$T_3 = T_x \left(\frac{v_3}{v_x} \right) = T_x r_c = (1738 \text{ R})(1.4) = 2433 \text{ R}$$

$$T_4 = T_3 \left(\frac{v_3}{v_4} \right)^{k-1} = T_3 \left(\frac{r_c}{r} \right)^{k-1} = (2433 \text{ R}) \left(\frac{1.4}{15} \right)^{1.4-1} = 942.2 \text{ R}$$

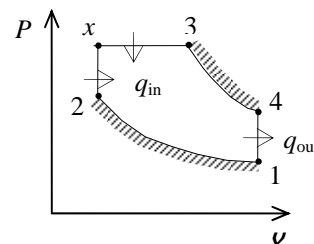

Applying the first law to each of the processes gives

$$w_{1-2} = c_v(T_2 - T_1) = (0.171 \text{ Btu}/\text{lbm}\cdot\text{R})(1580 - 535)\text{R} = 178.7 \text{ Btu}/\text{lbm}$$

$$q_{2-x} = c_v(T_x - T_2) = (0.171 \text{ Btu}/\text{lbm}\cdot\text{R})(1738 - 1580)\text{R} = 27.02 \text{ Btu}/\text{lbm}$$

$$q_{x-3} = c_p(T_3 - T_x) = (0.240 \text{ Btu}/\text{lbm}\cdot\text{R})(2433 - 1738)\text{R} = 166.8 \text{ Btu}/\text{lbm}$$

$$w_{x-3} = q_{x-3} - c_v(T_3 - T_x) = 166.8 \text{ Btu}/\text{lbm} - (0.171 \text{ Btu}/\text{lbm}\cdot\text{R})(2433 - 1738)\text{R} = 47.96 \text{ Btu}/\text{lbm}$$

$$w_{3-4} = c_v(T_3 - T_4) = (0.171 \text{ Btu}/\text{lbm}\cdot\text{R})(2433 - 942.2)\text{R} = 254.9 \text{ Btu}/\text{lbm}$$

The net work of the cycle is

$$w_{\text{net}} = w_{3-4} + w_{x-3} - w_{1-2} = 254.9 + 47.96 - 178.7 = \mathbf{124.2 \text{ Btu}/\text{lbm}}$$

and the net heat addition is

$$q_{\text{in}} = q_{2-x} + q_{x-3} = 27.02 + 166.8 = \mathbf{193.8 \text{ Btu}/\text{lbm}}$$

Hence, the thermal efficiency is

$$\eta_{\text{th}} = \frac{w_{\text{net}}}{q_{\text{in}}} = \frac{124.2 \text{ Btu}/\text{lbm}}{193.8 \text{ Btu}/\text{lbm}} = \mathbf{0.641}$$

9-70 An expression for the thermal efficiency of a dual cycle is to be developed and the thermal efficiency for a given case is to be calculated.

Assumptions 1 The air-standard assumptions are applicable. **2** Kinetic and potential energy changes are negligible. **3** Air is an ideal gas with constant specific heats.

Properties The properties of air at room temperature are $c_p = 1.005 \text{ kJ/kg}\cdot\text{K}$, $c_v = 0.718 \text{ kJ/kg}\cdot\text{K}$, $R = 0.287 \text{ kJ/kg}\cdot\text{K}$, and $k = 1.4$ (Table A-2)

Analysis The thermal efficiency of a dual cycle may be expressed as

$$\eta_{\text{th}} = 1 - \frac{q_{\text{out}}}{q_{\text{in}}} = 1 - \frac{c_v(T_4 - T_1)}{c_v(T_x - T_2) + c_p(T_3 - T_x)}$$

By applying the isentropic process relations for ideal gases with constant specific heats to the processes 1-2 and 3-4, as well as the ideal gas equation of state, the temperatures may be eliminated from the thermal efficiency expression. This yields the result

$$\eta_{\text{th}} = 1 - \frac{1}{r^{k-1}} \left[\frac{r_p r_c^k - 1}{k r_p (r_c - 1) + r_p - 1} \right]$$

where

$$r_p = \frac{P_x}{P_2} \quad \text{and} \quad r_c = \frac{v_3}{v_x}$$

When $r_c = r_p$, we obtain

$$\eta_{\text{th}} = 1 - \frac{1}{r^{k-1}} \left(\frac{r_p^{k+1} - 1}{k(r_p^2 - r_p) + r_p - 1} \right)$$

For the case $r = 20$ and $r_p = 2$,

$$\eta_{\text{th}} = 1 - \frac{1}{20^{1.4-1}} \left(\frac{2^{1.4+1} - 1}{1.4(2^2 - 2) + 2 - 1} \right) = \mathbf{0.660}$$

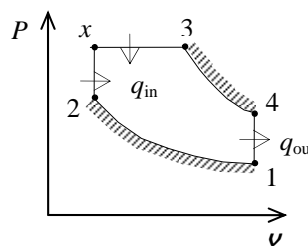

9-71 An expression regarding the thermal efficiency of a dual cycle for a special case is to be obtained.

Assumptions 1 The air-standard assumptions are applicable. **2** Kinetic and potential energy changes are negligible. **3** Air is an ideal gas with constant specific heats.

Analysis The thermal efficiency of a dual cycle may be expressed as

$$\eta_{\text{th}} = 1 - \frac{q_{\text{out}}}{q_{\text{in}}} = 1 - \frac{c_v(T_4 - T_1)}{c_v(T_x - T_2) + c_p(T_3 - T_x)}$$

By applying the isentropic process relations for ideal gases with constant specific heats to the processes 1-2 and 3-4, as well as the ideal gas equation of state, the temperatures may be eliminated from the thermal efficiency expression. This yields the result

$$\eta_{\text{th}} = 1 - \frac{1}{r^{k-1}} \left[\frac{r_p r_c^k - 1}{k r_p (r_c - 1) + r_p - 1} \right]$$

where

$$r_p = \frac{P_x}{P_2} \quad \text{and} \quad r_c = \frac{v_3}{v_x}$$

When $r_c = r_p$, we obtain

$$\eta_{\text{th}} = 1 - \frac{1}{r^{k-1}} \left(\frac{r_p^{k+1} - 1}{k(r_p^2 - r_p) + r_p - 1} \right)$$

Rearrangement of this result gives

$$\frac{r_p^{k+1} - 1}{k(r_p^2 - r_p) + r_p - 1} = (1 - \eta_{\text{th}}) r^{k-1}$$

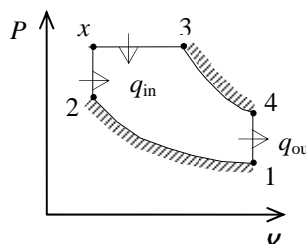

9-72 A six-cylinder compression ignition engine operates on the ideal Diesel cycle. The maximum temperature in the cycle, the cutoff ratio, the net work output per cycle, the thermal efficiency, the mean effective pressure, the net power output, and the specific fuel consumption are to be determined.

Assumptions 1 The air-standard assumptions are applicable. **2** Kinetic and potential energy changes are negligible. **3** Air is an ideal gas with constant specific heats.

Properties The properties of air at 850 K are $c_p = 1.110$ kJ/kg·K, $c_v = 0.823$ kJ/kg·K, $R = 0.287$ kJ/kg·K, and $k = 1.349$ (Table A-2b).

Analysis (a) Process 1-2: Isentropic compression

$$T_2 = T_1 \left(\frac{v_1}{v_2} \right)^{k-1} = (328 \text{ K})(17)^{1.349-1} = 881.7 \text{ K}$$

$$P_2 = P_1 \left(\frac{v_1}{v_2} \right)^k = (95 \text{ kPa})(17)^{1.349} = 4341 \text{ kPa}$$

The clearance volume and the total volume of the engine at the beginning of compression process (state 1) are

$$r = \frac{v_c + v_d}{v_c} \rightarrow 17 = \frac{v_c + 0.0045 \text{ m}^3}{v_c}$$

$$v_c = 0.0002813 \text{ m}^3$$

$$v_1 = v_c + v_d = 0.0002813 + 0.0045 = 0.004781 \text{ m}^3$$

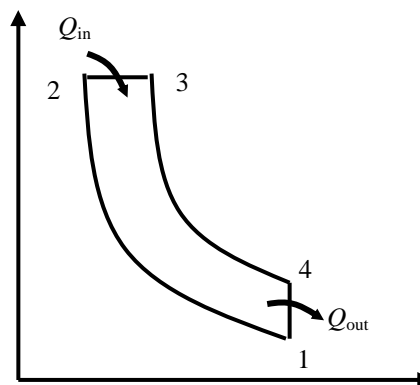

The total mass contained in the cylinder is

$$m = \frac{P_1 v_1}{RT_1} = \frac{(95 \text{ kPa})(0.004781 \text{ m}^3)}{(0.287 \text{ kPa} \cdot \text{m}^3/\text{kg} \cdot \text{K})(328 \text{ K})} = 0.004825 \text{ kg}$$

The mass of fuel burned during one cycle is

$$AF = \frac{m_a}{m_f} = \frac{m - m_f}{m_f} \rightarrow 24 = \frac{(0.004825 \text{ kg}) - m_f}{m_f} \rightarrow m_f = 0.000193 \text{ kg}$$

Process 2-3: constant pressure heat addition

$$Q_{in} = m_f q_{HV} \eta_c = (0.000193 \text{ kg})(42,500 \text{ kJ/kg})(0.98) = 8.039 \text{ kJ}$$

$$Q_{in} = mc_v(T_3 - T_2) \rightarrow 8.039 \text{ kJ} = (0.004825 \text{ kg})(0.823 \text{ kJ/kg} \cdot \text{K})(T_3 - 881.7 \text{ K}) \rightarrow T_3 = \mathbf{2383 \text{ K}}$$

The cutoff ratio is

$$\beta = \frac{T_3}{T_2} = \frac{2383 \text{ K}}{881.7 \text{ K}} = \mathbf{2.7}$$

$$(b) \quad v_2 = \frac{v_1}{r} = \frac{0.004781 \text{ m}^3}{17} = 0.0002813 \text{ m}^3$$

$$v_3 = \beta v_2 = (2.7)(0.0002813 \text{ m}^3) = 0.00076 \text{ m}^3$$

$$v_4 = v_1$$

$$P_3 = P_2$$

Process 3-4: isentropic expansion.

$$T_4 = T_3 \left(\frac{V_3}{V_4} \right)^{k-1} = (2383 \text{ K}) \left(\frac{0.00076 \text{ m}^3}{0.004781 \text{ m}^3} \right)^{1.349-1} = 1254 \text{ K}$$

$$P_4 = P_3 \left(\frac{V_3}{V_4} \right)^k = (4341 \text{ kPa}) \left(\frac{0.00076 \text{ m}^3}{0.004781 \text{ m}^3} \right)^{1.349} = 363.2 \text{ kPa}$$

Process 4-1: constant volume heat rejection.

$$Q_{\text{out}} = mc_v (T_4 - T_1) = (0.004825 \text{ kg})(0.823 \text{ kJ/kg} \cdot \text{K})(1254 - 328) \text{ K} = 3.677 \text{ kJ}$$

The net work output and the thermal efficiency are

$$W_{\text{net,out}} = Q_{\text{in}} - Q_{\text{out}} = 8.039 - 3.677 = \mathbf{4.361 \text{ kJ}}$$

$$\eta_{\text{th}} = \frac{W_{\text{net,out}}}{Q_{\text{in}}} = \frac{4.361 \text{ kJ}}{8.039 \text{ kJ}} = \mathbf{0.543}$$

(c) The mean effective pressure is determined to be

$$\text{MEP} = \frac{W_{\text{net,out}}}{V_1 - V_2} = \frac{4.361 \text{ kJ}}{(0.004781 - 0.0002813) \text{ m}^3} \left(\frac{\text{kPa} \cdot \text{m}^3}{\text{kJ}} \right) = \mathbf{969.2 \text{ kPa}}$$

(d) The power for engine speed of 2000 rpm is

$$\dot{W}_{\text{net}} = W_{\text{net}} \frac{\dot{n}}{2} = (4.361 \text{ kJ/cycle}) \frac{2000 \text{ (rev/min)}}{(2 \text{ rev/cycle})} \left(\frac{1 \text{ min}}{60 \text{ s}} \right) = \mathbf{72.7 \text{ kW}}$$

Note that there are two revolutions in one cycle in four-stroke engines.

(e) Finally, the specific fuel consumption is

$$\text{sfc} = \frac{m_f}{W_{\text{net}}} = \frac{0.000193 \text{ kg}}{4.361 \text{ kJ/kg}} \left(\frac{1000 \text{ g}}{1 \text{ kg}} \right) \left(\frac{3600 \text{ kJ}}{1 \text{ kWh}} \right) = \mathbf{159.3 \text{ g/kWh}}$$

Stirling and Ericsson Cycles

9-73C The efficiencies of the Carnot and the Stirling cycles would be the same, the efficiency of the Otto cycle would be less.

9-74C The efficiencies of the Carnot and the Ericsson cycles would be the same, the efficiency of the Diesel cycle would be less.

9-75C The Stirling cycle.

9-76C The two isentropic processes of the Carnot cycle are replaced by two constant pressure regeneration processes in the Ericsson cycle.

9-77 An ideal steady-flow Ericsson engine with air as the working fluid is considered. The maximum pressure in the cycle, the net work output, and the thermal efficiency of the cycle are to be determined.

Assumptions Air is an ideal gas.

Properties The gas constant of air is $R = 0.287 \text{ kJ/kg}\cdot\text{K}$ (Table A-1).

Analysis (a) The entropy change during process 3-4 is

$$s_4 - s_3 = -\frac{q_{34,\text{out}}}{T_0} = -\frac{150 \text{ kJ/kg}}{300 \text{ K}} = -0.5 \text{ kJ/kg}\cdot\text{K}$$

and

$$\begin{aligned} s_4 - s_3 &= c_p \ln \frac{T_4}{T_3} - R \ln \frac{P_4}{P_3} \\ &= -(0.287 \text{ kJ/kg}\cdot\text{K}) \ln \frac{P_4}{120 \text{ kPa}} = -0.5 \text{ kJ/kg}\cdot\text{K} \end{aligned}$$

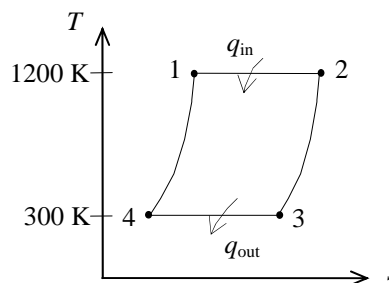

It yields $P_4 = \mathbf{685.2 \text{ kPa}}$

(b) For reversible cycles,

$$\frac{q_{\text{out}}}{q_{\text{in}}} = \frac{T_L}{T_H} \longrightarrow q_{\text{in}} = \frac{T_H}{T_L} q_{\text{out}} = \frac{1200 \text{ K}}{300 \text{ K}} (150 \text{ kJ/kg}) = 600 \text{ kJ/kg}$$

Thus,

$$w_{\text{net,out}} = q_{\text{in}} - q_{\text{out}} = 600 - 150 = \mathbf{450 \text{ kJ/kg}}$$

(c) The thermal efficiency of this totally reversible cycle is determined from

$$\eta_{\text{th}} = 1 - \frac{T_L}{T_H} = 1 - \frac{300 \text{ K}}{1200 \text{ K}} = \mathbf{75.0\%}$$

9-78 An ideal Stirling engine with air as the working fluid operates between the specified temperature and pressure limits. The net work produced per cycle and the thermal efficiency of the cycle are to be determined.

Assumptions Air is an ideal gas with constant specific heats.

Properties The properties of air at room temperature are $c_p = 1.005 \text{ kJ/kg}\cdot\text{K}$, $c_v = 0.718 \text{ kJ/kg}\cdot\text{K}$, $R = 0.287 \text{ kJ/kg}\cdot\text{K}$, and $k = 1.4$ (Table A-2a).

Analysis Since the specific volume is constant during process 2-3,

$$P_2 = P_3 \frac{T_2}{T_3} = (100 \text{ kPa}) \left(\frac{800 \text{ K}}{300 \text{ K}} \right) = 266.7 \text{ kPa}$$

Heat is only added to the system during reversible process 1-2. Then,

$$\begin{aligned} s_2 - s_1 &= c_v \ln \frac{T_2}{T_1} - R \ln \frac{P_2}{P_1} \\ &= 0 - (0.287 \text{ kJ/kg}\cdot\text{K}) \ln \left(\frac{266.7 \text{ kPa}}{2000 \text{ kPa}} \right) \\ &= 0.5782 \text{ kJ/kg}\cdot\text{K} \end{aligned}$$

$$q_{\text{in}} = T_1 (s_2 - s_1) = (800 \text{ K})(0.5782 \text{ kJ/kg}\cdot\text{K}) = 462.6 \text{ kJ/kg}$$

The thermal efficiency of this totally reversible cycle is determined from

$$\eta_{\text{th}} = 1 - \frac{T_L}{T_H} = 1 - \frac{300 \text{ K}}{800 \text{ K}} = \mathbf{0.625}$$

Then,

$$W_{\text{net}} = \eta_{\text{th}} m q_{\text{in}} = (0.625)(1 \text{ kg})(462.6 \text{ kJ/kg}) = \mathbf{289.1 \text{ kJ}}$$

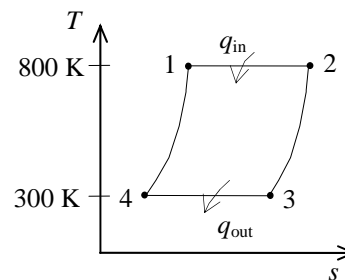

9-79 An ideal Stirling engine with air as the working fluid operates between the specified temperature and pressure limits. The power produced and the rate of heat input are to be determined.

Assumptions Air is an ideal gas with constant specific heats.

Properties The properties of air at room temperature are $c_p = 1.005 \text{ kJ/kg}\cdot\text{K}$, $c_v = 0.718 \text{ kJ/kg}\cdot\text{K}$, $R = 0.287 \text{ kJ/kg}\cdot\text{K}$, and $k = 1.4$ (Table A-2a).

Analysis Since the specific volume is constant during process 2-3,

$$P_2 = P_3 \frac{T_2}{T_3} = (100 \text{ kPa}) \left(\frac{800 \text{ K}}{300 \text{ K}} \right) = 266.7 \text{ kPa}$$

Heat is only added to the system during reversible process 1-2. Then,

$$\begin{aligned} s_2 - s_1 &= c_v \ln \frac{T_2}{T_1} - R \ln \frac{P_2}{P_1} \\ &= 0 - (0.287 \text{ kJ/kg}\cdot\text{K}) \ln \left(\frac{266.7 \text{ kPa}}{2000 \text{ kPa}} \right) \\ &= 0.5782 \text{ kJ/kg}\cdot\text{K} \end{aligned}$$

$$q_{\text{in}} = T_1 (s_2 - s_1) = (800 \text{ K})(0.5782 \text{ kJ/kg}\cdot\text{K}) = 462.6 \text{ kJ/kg}$$

The thermal efficiency of this totally reversible cycle is determined from

$$\eta_{\text{th}} = 1 - \frac{T_L}{T_H} = 1 - \frac{300 \text{ K}}{800 \text{ K}} = 0.625$$

Then,

$$W_{\text{net}} = \eta_{\text{th}} m q_{\text{in}} = (0.625)(1 \text{ kg})(462.6 \text{ kJ/kg}) = 289.1 \text{ kJ}$$

The rate at which heat is added to this engine is

$$\dot{Q}_{\text{in}} = m q_{\text{in}} \dot{n} = (1 \text{ kg/cycle})(462.6 \text{ kJ/kg})(500/60 \text{ cycle/s}) = \mathbf{3855 \text{ kW}}$$

while the power produced by the engine is

$$\dot{W}_{\text{net}} = W_{\text{net}} \dot{n} = (289.1 \text{ kJ/cycle})(500/60 \text{ cycle/s}) = \mathbf{2409 \text{ kW}}$$

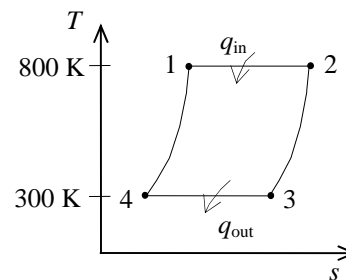

9-80E An ideal Stirling engine with hydrogen as the working fluid operates between the specified temperature limits. The amount of external heat addition, external heat rejection, and heat transfer between the working fluid and regenerator per cycle are to be determined.

Assumptions Hydrogen is an ideal gas with constant specific heats.

Properties The properties of hydrogen at room temperature are $R = 5.3224 \text{ psia}\cdot\text{ft}^3/\text{lbm}\cdot\text{R}$, $R = 0.9851 \text{ Btu}/\text{lbm}\cdot\text{R}$, $c_p = 3.43 \text{ Btu}/\text{lbm}\cdot\text{R}$, $c_v = 2.44 \text{ Btu}/\text{lbm}\cdot\text{R}$, and $k = 1.404$ (Table A-2Ea).

Analysis The mass of the air contained in this engine is

$$m = \frac{P_1 V_1}{RT_1} = \frac{(400 \text{ psia})(0.1 \text{ ft}^3)}{(5.3224 \text{ psia}\cdot\text{ft}^3/\text{lbm}\cdot\text{R})(1100 \text{ R})} = 0.006832 \text{ lbm}$$

At the end of the compression, the pressure will be

$$P_2 = P_1 \frac{V_1}{V_2} = (400 \text{ psia}) \left(\frac{0.1 \text{ ft}^3}{1 \text{ ft}^3} \right) = 40 \text{ psia}$$

The entropy change is

$$\begin{aligned} s_2 - s_1 = s_3 - s_4 &= c_v \ln \frac{T_2}{T_1} - R \ln \frac{P_2}{P_1} \\ &= 0 - (0.9851 \text{ Btu}/\text{lbm}\cdot\text{R}) \ln \left(\frac{40 \text{ psia}}{400 \text{ psia}} \right) = 2.268 \text{ Btu}/\text{lbm}\cdot\text{R} \end{aligned}$$

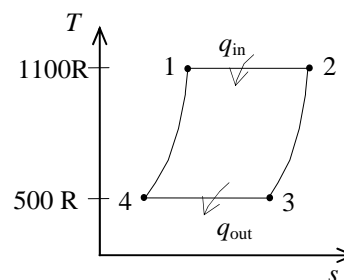

Since the processes are reversible,

$$Q_{\text{in}} = mT_1(s_2 - s_1) = (0.006832 \text{ lbm})(1100 \text{ R})(2.268 \text{ Btu}/\text{lbm}\cdot\text{R}) = \mathbf{17.0 \text{ Btu}}$$

$$Q_{\text{out}} = mT_3(s_4 - s_3) = (0.006832 \text{ lbm})(500 \text{ R})(2.268 \text{ Btu}/\text{lbm}\cdot\text{R}) = \mathbf{7.75 \text{ Btu}}$$

Applying the first law to the process where the gas passes through the regenerator gives

$$Q_{\text{regen}} = mc_v(T_1 - T_4) = (0.006832 \text{ lbm})(2.44 \text{ Btu}/\text{lbm}\cdot\text{R})(1100 - 500)\text{R} = \mathbf{10.0 \text{ Btu}}$$

9-81E An ideal Stirling engine with air as the working fluid operates between specified pressure limits. The heat added to and rejected by this cycle, and the net work produced by the cycle are to be determined.

Assumptions Air is an ideal gas with constant specific heats.

Properties The properties of air at room temperature are $R = 0.3704 \text{ psia}\cdot\text{ft}^3/\text{lbm}\cdot\text{R}$, $R = 0.06855 \text{ Btu}/\text{lbm}\cdot\text{R}$, $c_p = 0.240 \text{ Btu}/\text{lbm}\cdot\text{R}$, $c_v = 0.171 \text{ Btu}/\text{lbm}\cdot\text{R}$, and $k = 1.4$ (Table A-2Ea).

Analysis Applying the ideal gas equation to the isothermal process 3-4 gives

$$P_4 = P_3 \frac{v_3}{v_4} = (10 \text{ psia})(10) = 100 \text{ psia}$$

Since process 4-1 is a constant volume process,,

$$T_1 = T_4 \left(\frac{P_1}{P_4} \right) = (560 \text{ R}) \left(\frac{600 \text{ psia}}{100 \text{ psia}} \right) = 3360 \text{ R}$$

According to first law and work integral,

$$q_{\text{in}} = w_{1-2} = RT_1 \ln \frac{v_2}{v_1} = (0.06855 \text{ Btu}/\text{lbm}\cdot\text{R})(3360 \text{ R}) \ln(10) = \mathbf{530.3 \text{ Btu}/\text{lbm}}$$

and

$$q_{\text{out}} = w_{3-4} = RT_3 \ln \frac{v_4}{v_3} = (0.06855 \text{ Btu}/\text{lbm}\cdot\text{R})(560 \text{ R}) \ln\left(\frac{1}{10}\right) = \mathbf{88.4 \text{ Btu}/\text{lbm}}$$

The net work is then

$$w_{\text{net}} = q_{\text{in}} - q_{\text{out}} = 530.3 - 88.4 = \mathbf{441.9 \text{ Btu}/\text{lbm}}$$

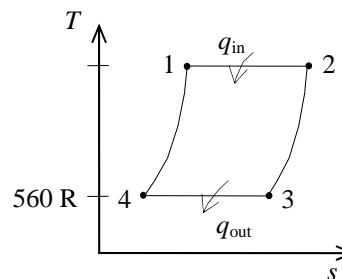

9-82E An ideal Stirling engine with air as the working fluid operates between specified pressure limits. The heat transfer in the regenerator is to be determined.

Assumptions Air is an ideal gas with constant specific heats.

Properties The properties of air at room temperature are $R = 0.3704 \text{ psia}\cdot\text{ft}^3/\text{lbm}\cdot\text{R}$, $c_p = 0.240 \text{ Btu}/\text{lbm}\cdot\text{R}$, $c_v = 0.171 \text{ Btu}/\text{lbm}\cdot\text{R}$, and $k = 1.4$ (Table A-2Ea).

Analysis Applying the ideal gas equation to the isothermal process 1-2 gives

$$P_2 = P_1 \frac{v_1}{v_2} = (600 \text{ psia}) \left(\frac{1}{10} \right) = 60 \text{ psia}$$

Since process 2-3 is a constant-volume process,

$$T_2 = T_3 \left(\frac{P_2}{P_3} \right) = (560 \text{ R}) \left(\frac{60 \text{ psia}}{10 \text{ psia}} \right) = 3360 \text{ R}$$

Application of the first law to process 2-3 gives

$$q_{\text{regen}} = c_v (T_2 - T_3) = (0.171 \text{ Btu}/\text{lbm}\cdot\text{R})(3360 - 560) \text{ R} = \mathbf{478.8 \text{ Btu}/\text{lbm}}$$

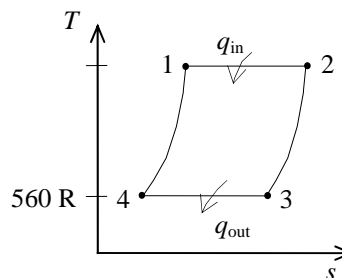

9-83 An ideal Ericsson cycle operates between the specified temperature limits. The rate of heat addition is to be determined.

Analysis The thermal efficiency of this totally reversible cycle is determined from

$$\eta_{\text{th}} = 1 - \frac{T_L}{T_H} = 1 - \frac{280 \text{ K}}{900 \text{ K}} = 0.6889$$

According to the general definition of the thermal efficiency, the rate of heat addition is

$$\dot{Q}_{\text{in}} = \frac{\dot{W}_{\text{net}}}{\eta_{\text{th}}} = \frac{500 \text{ kW}}{0.6889} = \mathbf{726 \text{ kW}}$$

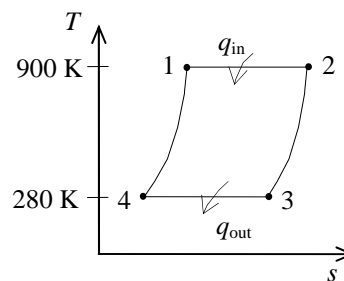

9-84 An ideal Ericsson cycle operates between the specified temperature limits. The power produced by the cycle is to be determined.

Analysis The power output is 500 kW when the cycle is repeated 2000 times per minute. Then the work per cycle is

$$W_{\text{net}} = \frac{\dot{W}_{\text{net}}}{\dot{n}} = \frac{500 \text{ kJ/s}}{(2000/60) \text{ cycle/s}} = 15 \text{ kJ/cycle}$$

When the cycle is repeated 3000 times per minute, the power output will be

$$\dot{W}_{\text{net}} = \dot{n} W_{\text{net}} = (3000/60 \text{ cycle/s})(15 \text{ kJ/cycle}) = \mathbf{750 \text{ kW}}$$

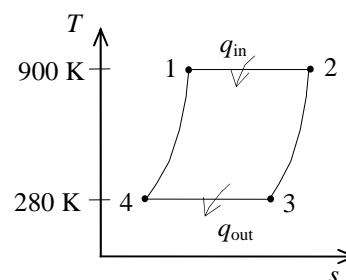

Ideal and Actual Gas-Turbine (Brayton) Cycles

9-85C In gas turbine engines a gas is compressed, and thus the compression work requirements are very large since the steady-flow work is proportional to the specific volume.

9-86C They are (1) isentropic compression (in a compressor), (2) $P = \text{constant}$ heat addition, (3) isentropic expansion (in a turbine), and (4) $P = \text{constant}$ heat rejection.

9-87C For fixed maximum and minimum temperatures, (a) the thermal efficiency increases with pressure ratio, (b) the net work first increases with pressure ratio, reaches a maximum, and then decreases.

9-88C Back work ratio is the ratio of the compressor (or pump) work input to the turbine work output. It is usually between 0.40 and 0.6 for gas turbine engines.

9-89C As a result of turbine and compressor inefficiencies, (a) the back work ratio increases, and (b) the thermal efficiency decreases.

9-90E A simple ideal Brayton cycle with air as the working fluid has a pressure ratio of 10. The air temperature at the compressor exit, the back work ratio, and the thermal efficiency are to be determined.

Assumptions 1 Steady operating conditions exist. 2 The air-standard assumptions are applicable. 3 Kinetic and potential energy changes are negligible. 4 Air is an ideal gas with variable specific heats.

Properties The properties of air are given in Table A-17E.

Analysis (a) Noting that process 1-2 is isentropic,

$$T_1 = 520 \text{ R} \longrightarrow \begin{aligned} h_1 &= 124.27 \text{ Btu/lbm} \\ P_{r_1} &= 1.2147 \end{aligned}$$

$$P_{r_2} = \frac{P_2}{P_1} P_{r_1} = (10)(1.2147) = 12.147 \longrightarrow \begin{aligned} T_2 &= \mathbf{996.5 \text{ R}} \\ h_2 &= 240.11 \text{ Btu/lbm} \end{aligned}$$

(b) Process 3-4 is isentropic, and thus

$$T_3 = 2000 \text{ R} \longrightarrow \begin{aligned} h_3 &= 504.71 \text{ Btu/lbm} \\ P_{r_3} &= 174.0 \end{aligned}$$

$$P_{r_4} = \frac{P_4}{P_3} P_{r_3} = \left(\frac{1}{10}\right)(174.0) = 17.4 \longrightarrow h_4 = 265.83 \text{ Btu/lbm}$$

$$w_{C,\text{in}} = h_2 - h_1 = 240.11 - 124.27 = 115.84 \text{ Btu/lbm}$$

$$w_{T,\text{out}} = h_3 - h_4 = 504.71 - 265.83 = 238.88 \text{ Btu/lbm}$$

Then the back-work ratio becomes

$$r_{\text{bw}} = \frac{w_{C,\text{in}}}{w_{T,\text{out}}} = \frac{115.84 \text{ Btu/lbm}}{238.88 \text{ Btu/lbm}} = \mathbf{48.5\%}$$

$$(c) \quad q_{\text{in}} = h_3 - h_2 = 504.71 - 240.11 = 264.60 \text{ Btu/lbm}$$

$$w_{\text{net,out}} = w_{T,\text{out}} - w_{C,\text{in}} = 238.88 - 115.84 = 123.04 \text{ Btu/lbm}$$

$$\eta_{\text{th}} = \frac{w_{\text{net,out}}}{q_{\text{in}}} = \frac{123.04 \text{ Btu/lbm}}{264.60 \text{ Btu/lbm}} = \mathbf{46.5\%}$$

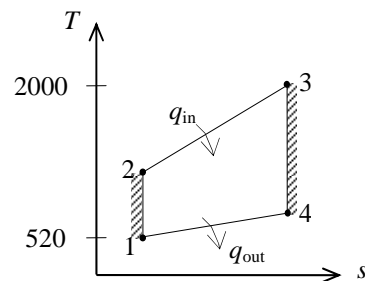

9-91 [Also solved by EES on enclosed CD] A simple Brayton cycle with air as the working fluid has a pressure ratio of 8. The air temperature at the turbine exit, the net work output, and the thermal efficiency are to be determined.

Assumptions 1 Steady operating conditions exist. 2 The air-standard assumptions are applicable. 3 Kinetic and potential energy changes are negligible. 4 Air is an ideal gas with variable specific heats.

Properties The properties of air are given in Table A-17.

Analysis (a) Noting that process 1-2s is isentropic,

$$T_1 = 310 \text{ K} \longrightarrow \begin{aligned} h_1 &= 310.24 \text{ kJ/kg} \\ P_{r_1} &= 1.5546 \end{aligned}$$

$$P_{r_2} = \frac{P_2}{P_1} P_{r_1} = (8)(1.5546) = 12.44 \longrightarrow h_{2s} = 562.58 \text{ kJ/kg} \text{ and } T_{2s} = 557.25 \text{ K}$$

$$\begin{aligned} \eta_C &= \frac{h_{2s} - h_1}{h_2 - h_1} \longrightarrow h_2 = h_1 + \frac{h_{2s} - h_1}{\eta_C} \\ &= 310.24 + \frac{562.58 - 310.24}{0.75} = 646.7 \text{ kJ/kg} \end{aligned}$$

$$T_3 = 1160 \text{ K} \longrightarrow \begin{aligned} h_3 &= 1230.92 \text{ kJ/kg} \\ P_{r_3} &= 207.2 \end{aligned}$$

$$P_{r_4} = \frac{P_4}{P_3} P_{r_3} = \left(\frac{1}{8}\right)(207.2) = 25.90 \longrightarrow h_{4s} = 692.19 \text{ kJ/kg} \text{ and } T_{4s} = 680.3 \text{ K}$$

$$\begin{aligned} \eta_T &= \frac{h_3 - h_4}{h_3 - h_{4s}} \longrightarrow h_4 = h_3 - \eta_T (h_3 - h_{4s}) \\ &= 1230.92 - (0.82)(1230.92 - 692.19) \\ &= 789.16 \text{ kJ/kg} \end{aligned}$$

Thus,

$$T_4 = \mathbf{770.1 \text{ K}}$$

$$(b) \quad q_{\text{in}} = h_3 - h_2 = 1230.92 - 646.7 = 584.2 \text{ kJ/kg}$$

$$q_{\text{out}} = h_4 - h_1 = 789.16 - 310.24 = 478.92 \text{ kJ/kg}$$

$$w_{\text{net,out}} = q_{\text{in}} - q_{\text{out}} = 584.2 - 478.92 = \mathbf{105.3 \text{ kJ/kg}}$$

$$(c) \quad \eta_{\text{th}} = \frac{w_{\text{net,out}}}{q_{\text{in}}} = \frac{105.3 \text{ kJ/kg}}{584.2 \text{ kJ/kg}} = \mathbf{18.0\%}$$

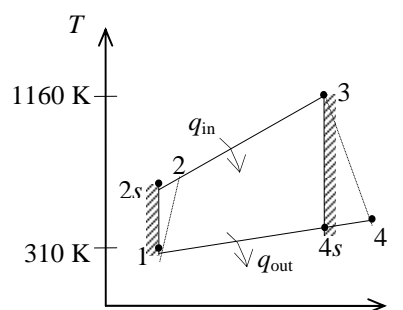

9-92 EES Problem 9-91 is reconsidered. The mass flow rate, pressure ratio, turbine inlet temperature, and the isentropic efficiencies of the turbine and compressor are to be varied and a general solution for the problem by taking advantage of the diagram window method for supplying data to EES is to be developed.

Analysis Using EES, the problem is solved as follows:

"Input data - from diagram window"

```
{P_ratio = 8}
{T[1] = 310 [K]
P[1]= 100 [kPa]
T[3] = 1160 [K]
m_dot = 20 [kg/s]
Eta_c = 75/100
Eta_t = 82/100}
```

"Inlet conditions"

```
h[1]=ENTHALPY(Air,T=T[1])
s[1]=ENTROPY(Air,T=T[1],P=P[1])
```

"Compressor analysis"

```
s_s[2]=s[1] "For the ideal case the entropies are constant across the compressor"
P_ratio=P[2]/P[1]"Definition of pressure ratio - to find P[2]"
T_s[2]=TEMPERATURE(Air,s=s_s[2],P=P[2]) "T_s[2] is the isentropic value of T[2] at
compressor exit"
h_s[2]=ENTHALPY(Air,T=T_s[2])
Eta_c =(h_s[2]-h[1])/(h[2]-h[1]) "Compressor adiabatic efficiency; Eta_c =
W_dot_c_ideal/W_dot_c_actual."
m_dot*h[1] +W_dot_c=m_dot*h[2] "SSSF First Law for the actual compressor, assuming:
adiabatic, ke=pe=0"
"External heat exchanger analysis"
P[3]=P[2]"process 2-3 is SSSF constant pressure"
h[3]=ENTHALPY(Air,T=T[3])
m_dot*h[2] + Q_dot_in= m_dot*h[3]"SSSF First Law for the heat exchanger, assuming W=0,
ke=pe=0"
```

"Turbine analysis"

```
s[3]=ENTROPY(Air,T=T[3],P=P[3])
s_s[4]=s[3] "For the ideal case the entropies are constant across the turbine"
P_ratio= P[3] /P[4]
T_s[4]=TEMPERATURE(Air,s=s_s[4],P=P[4]) "Ts[4] is the isentropic value of T[4] at turbine exit"
h_s[4]=ENTHALPY(Air,T=T_s[4]) "Eta_t = W_dot_t /Wts_dot turbine adiabatic efficiency,
Wts_dot > W_dot_t"
Eta_t=(h[3]-h[4])/(h[3]-h_s[4])
m_dot*h[3] = W_dot_t + m_dot*h[4] "SSSF First Law for the actual compressor, assuming:
adiabatic, ke=pe=0"
```

"Cycle analysis"

```
W_dot_net=W_dot_t-W_dot_c"Definition of the net cycle work, kW"
Eta=W_dot_net/Q_dot_in"Cycle thermal efficiency"
Bwr=W_dot_c/W_dot_t "Back work ratio"
```

"The following state points are determined only to produce a T-s plot"

```
T[2]=temperature('air',h=h[2])
T[4]=temperature('air',h=h[4])
s[2]=entropy('air',T=T[2],P=P[2])
s[4]=entropy('air',T=T[4],P=P[4])
```

Bwr	η	P_{ratio}	W_c [kW]	W_{net} [kW]	W_t [kW]	Q_{in} [kW]
0.5229	0.1	2	1818	1659	3477	16587
0.6305	0.1644	4	4033	2364	6396	14373
0.7038	0.1814	6	5543	2333	7876	12862
0.7611	0.1806	8	6723	2110	8833	11682
0.8088	0.1702	10	7705	1822	9527	10700
0.85	0.1533	12	8553	1510	10063	9852
0.8864	0.131	14	9304	1192	10496	9102
0.9192	0.1041	16	9980	877.2	10857	8426
0.9491	0.07272	18	10596	567.9	11164	7809
0.9767	0.03675	20	11165	266.1	11431	7241

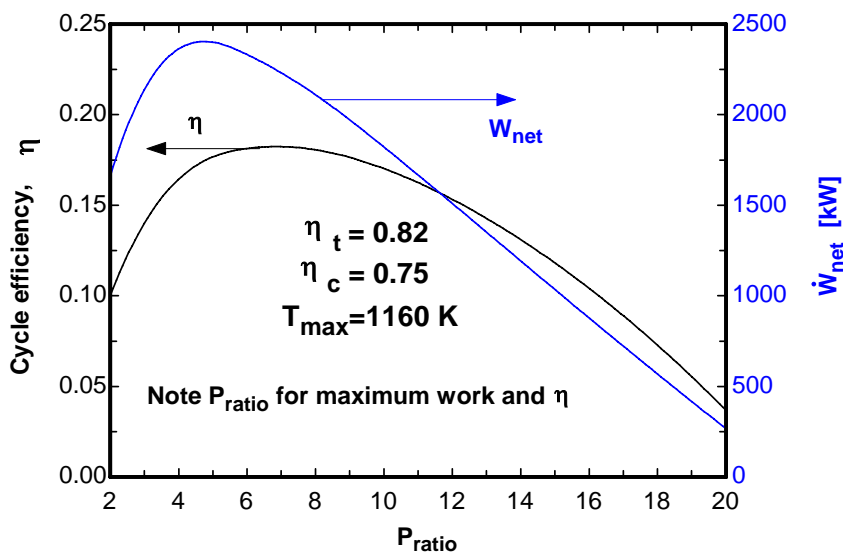
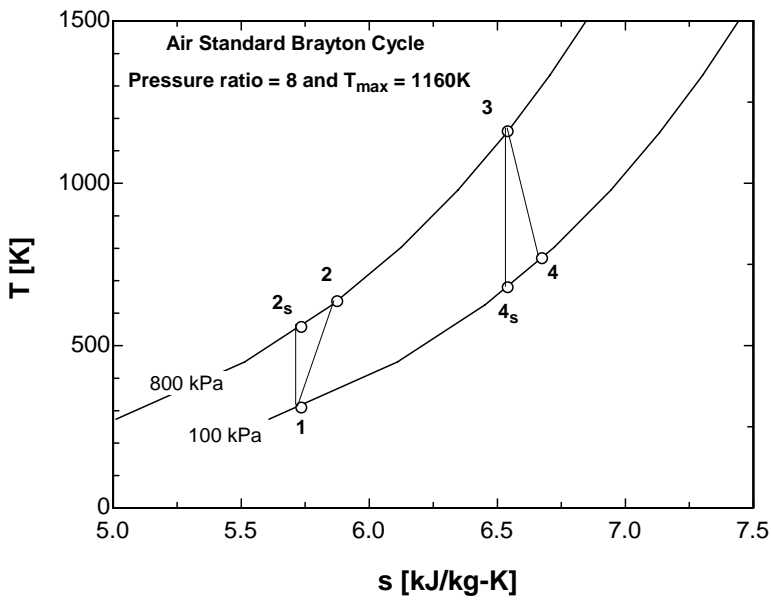

9-93 A simple Brayton cycle with air as the working fluid has a pressure ratio of 8. The air temperature at the turbine exit, the net work output, and the thermal efficiency are to be determined.

Assumptions 1 Steady operating conditions exist. 2 The air-standard assumptions are applicable. 3 Kinetic and potential energy changes are negligible. 4 Air is an ideal gas with constant specific heats.

Properties The properties of air at room temperature are $c_p = 1.005 \text{ kJ/kg}\cdot\text{K}$ and $k = 1.4$ (Table A-2).

Analysis (a) Using the compressor and turbine efficiency relations,

$$T_{2s} = T_1 \left(\frac{P_2}{P_1} \right)^{(k-1)/k} = (310 \text{ K})(8)^{0.4/1.4} = 561.5 \text{ K}$$

$$T_{4s} = T_3 \left(\frac{P_4}{P_3} \right)^{(k-1)/k} = (1160 \text{ K}) \left(\frac{1}{8} \right)^{0.4/1.4} = 640.4 \text{ K}$$

$$\eta_C = \frac{h_{2s} - h_1}{h_2 - h_1} = \frac{c_p(T_{2s} - T_1)}{c_p(T_2 - T_1)} \longrightarrow T_2 = T_1 + \frac{T_{2s} - T_1}{\eta_C}$$

$$= 310 + \frac{561.5 - 310}{0.75} = 645.3 \text{ K}$$

$$\eta_T = \frac{h_3 - h_4}{h_3 - h_{4s}} = \frac{c_p(T_3 - T_4)}{c_p(T_3 - T_{4s})} \longrightarrow T_4 = T_3 - \eta_T(T_3 - T_{4s})$$

$$= 1160 - (0.82)(1160 - 640.4)$$

$$= \mathbf{733.9 \text{ K}}$$

$$(b) \quad q_{in} = h_3 - h_2 = c_p(T_3 - T_2) = (1.005 \text{ kJ/kg}\cdot\text{K})(1160 - 645.3)\text{K} = 517.3 \text{ kJ/kg}$$

$$q_{out} = h_4 - h_1 = c_p(T_4 - T_1) = (1.005 \text{ kJ/kg}\cdot\text{K})(733.9 - 310)\text{K} = 426.0 \text{ kJ/kg}$$

$$w_{net,out} = q_{in} - q_{out} = 517.3 - 426.0 = \mathbf{91.3 \text{ kJ/kg}}$$

$$(c) \quad \eta_{th} = \frac{w_{net,out}}{q_{in}} = \frac{91.3 \text{ kJ/kg}}{517.3 \text{ kJ/kg}} = \mathbf{17.6\%}$$

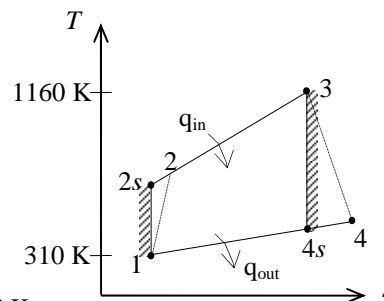

9-94 A simple ideal Brayton cycle with air as the working fluid operates between the specified temperature and pressure limits. The net work and the thermal efficiency are to be determined.

Assumptions 1 Steady operating conditions exist. 2 The air-standard assumptions are applicable. 3 Kinetic and potential energy changes are negligible. 4 Air is an ideal gas with constant specific heats.

Properties The properties of air at room temperature are $c_p = 1.005 \text{ kJ/kg}\cdot\text{K}$ and $k = 1.4$ (Table A-2a).

Analysis Using the isentropic relations for an ideal gas,

$$T_2 = T_1 \left(\frac{P_2}{P_1} \right)^{(k-1)/k} = (300 \text{ K}) \left(\frac{2000 \text{ kPa}}{100 \text{ kPa}} \right)^{0.4/1.4} = 706.1 \text{ K}$$

Similarly,

$$T_4 = T_3 \left(\frac{P_4}{P_3} \right)^{(k-1)/k} = (1000 \text{ K}) \left(\frac{100 \text{ kPa}}{2000 \text{ kPa}} \right)^{0.4/1.4} = 424.9 \text{ K}$$

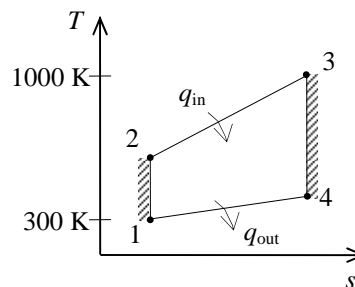

Applying the first law to the constant-pressure heat addition process 2-3 produces

$$q_{\text{in}} = h_3 - h_2 = c_p (T_3 - T_2) = (1.005 \text{ kJ/kg}\cdot\text{K})(1000 - 706.1)\text{K} = 295.4 \text{ kJ/kg}$$

Similarly,

$$q_{\text{out}} = h_4 - h_1 = c_p (T_4 - T_1) = (1.005 \text{ kJ/kg}\cdot\text{K})(424.9 - 300)\text{K} = 125.5 \text{ kJ/kg}$$

The net work production is then

$$w_{\text{net}} = q_{\text{in}} - q_{\text{out}} = 295.4 - 125.5 = \mathbf{169.9 \text{ kJ/kg}}$$

and the thermal efficiency of this cycle is

$$\eta_{\text{th}} = \frac{w_{\text{net}}}{q_{\text{in}}} = \frac{169.9 \text{ kJ/kg}}{295.4 \text{ kJ/kg}} = \mathbf{0.575}$$

9-95 A simple Brayton cycle with air as the working fluid operates between the specified temperature and pressure limits. The net work and the thermal efficiency are to be determined.

Assumptions 1 Steady operating conditions exist. 2 The air-standard assumptions are applicable. 3 Kinetic and potential energy changes are negligible. 4 Air is an ideal gas with constant specific heats.

Properties The properties of air at room temperature are $c_p = 1.005 \text{ kJ/kg}\cdot\text{K}$ and $k = 1.4$ (Table A-2a).

Analysis Using the isentropic relations for an ideal gas,

$$T_2 = T_1 \left(\frac{P_2}{P_1} \right)^{(k-1)/k} = (300 \text{ K}) \left(\frac{2000 \text{ kPa}}{100 \text{ kPa}} \right)^{0.4/1.4} = 706.1 \text{ K}$$

For the expansion process,

$$T_{4s} = T_3 \left(\frac{P_4}{P_3} \right)^{(k-1)/k} = (1000 \text{ K}) \left(\frac{100 \text{ kPa}}{2000 \text{ kPa}} \right)^{0.4/1.4} = 424.9 \text{ K}$$

$$\eta_T = \frac{h_3 - h_4}{h_3 - h_{4s}} = \frac{c_p(T_3 - T_4)}{c_p(T_3 - T_{4s})} \longrightarrow T_4 = T_3 - \eta_T(T_3 - T_{4s})$$

$$= 1000 - (0.90)(1000 - 424.9)$$

$$= 482.4 \text{ K}$$

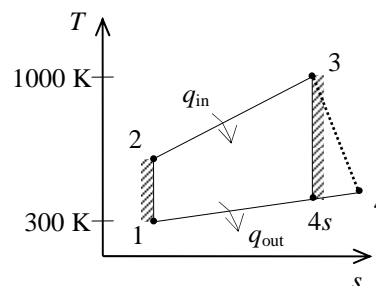

Applying the first law to the constant-pressure heat addition process 2-3 produces

$$Q_{in} = m(h_3 - h_2) = mc_p(T_3 - T_2) = (1 \text{ kg})(1.005 \text{ kJ/kg}\cdot\text{K})(1000 - 706.1) \text{ K} = 295.4 \text{ kJ}$$

Similarly,

$$Q_{out} = m(h_4 - h_1) = mc_p(T_4 - T_1) = (1 \text{ kg})(1.005 \text{ kJ/kg}\cdot\text{K})(482.4 - 300) \text{ K} = 183.3 \text{ kJ}$$

The net work production is then

$$W_{net} = Q_{in} - Q_{out} = 295.4 - 183.3 = \mathbf{112.1 \text{ kJ}}$$

and the thermal efficiency of this cycle is

$$\eta_{th} = \frac{W_{net}}{Q_{in}} = \frac{112.1 \text{ kJ}}{295.4 \text{ kJ}} = \mathbf{0.379}$$

9-96 A simple Brayton cycle with air as the working fluid operates between the specified temperature and pressure limits. The net work and the thermal efficiency are to be determined.

Assumptions 1 Steady operating conditions exist. 2 The air-standard assumptions are applicable. 3 Kinetic and potential energy changes are negligible. 4 Air is an ideal gas with constant specific heats.

Properties The properties of air at room temperature are $c_p = 1.005 \text{ kJ/kg}\cdot\text{K}$ and $k = 1.4$ (Table A-2a).

Analysis For the compression process,

$$T_{2s} = T_1 \left(\frac{P_2}{P_1} \right)^{(k-1)/k} = (300 \text{ K}) \left(\frac{2000 \text{ kPa}}{100 \text{ kPa}} \right)^{0.4/1.4} = 706.1 \text{ K}$$

$$\eta_C = \frac{h_{2s} - h_1}{h_2 - h_1} = \frac{c_p(T_{2s} - T_1)}{c_p(T_2 - T_1)} \longrightarrow T_2 = T_1 + \frac{T_{2s} - T_1}{\eta_C}$$

$$= 300 + \frac{706.1 - 300}{0.80} = 807.6 \text{ K}$$

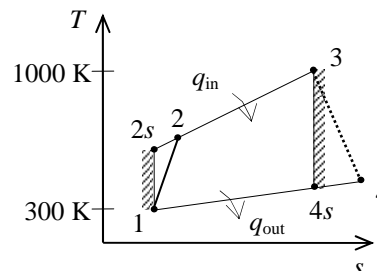

For the expansion process,

$$T_{4s} = T_3 \left(\frac{P_4}{P_3} \right)^{(k-1)/k} = (1000 \text{ K}) \left(\frac{100 \text{ kPa}}{2000 \text{ kPa}} \right)^{0.4/1.4} = 424.9 \text{ K}$$

$$\eta_T = \frac{h_3 - h_4}{h_3 - h_{4s}} = \frac{c_p(T_3 - T_4)}{c_p(T_3 - T_{4s})} \longrightarrow T_4 = T_3 - \eta_T(T_3 - T_{4s})$$

$$= 1000 - (0.90)(1000 - 424.9)$$

$$= 482.4 \text{ K}$$

Applying the first law to the constant-pressure heat addition process 2-3 produces

$$Q_{in} = m(h_3 - h_2) = mc_p(T_3 - T_2) = (1 \text{ kg})(1.005 \text{ kJ/kg}\cdot\text{K})(1000 - 807.6)\text{K} = 193.4 \text{ kJ}$$

Similarly,

$$Q_{out} = m(h_4 - h_1) = mc_p(T_4 - T_1) = (1 \text{ kg})(1.005 \text{ kJ/kg}\cdot\text{K})(482.4 - 300)\text{K} = 183.3 \text{ kJ}$$

The net work production is then

$$W_{net} = Q_{in} - Q_{out} = 193.4 - 183.3 = \mathbf{10.1 \text{ kJ}}$$

and the thermal efficiency of this cycle is

$$\eta_{th} = \frac{W_{net}}{Q_{in}} = \frac{10.1 \text{ kJ}}{193.4 \text{ kJ}} = \mathbf{0.0522}$$

9-97 A simple Brayton cycle with air as the working fluid operates between the specified temperature and pressure limits. The net work and the thermal efficiency are to be determined.

Assumptions 1 Steady operating conditions exist. 2 The air-standard assumptions are applicable. 3 Kinetic and potential energy changes are negligible. 4 Air is an ideal gas with constant specific heats.

Properties The properties of air at room temperature are $c_p = 1.005 \text{ kJ/kg}\cdot\text{K}$ and $k = 1.4$ (Table A-2a).

Analysis For the compression process,

$$T_{2s} = T_1 \left(\frac{P_2}{P_1} \right)^{(k-1)/k} = (300 \text{ K}) \left(\frac{2000 \text{ kPa}}{100 \text{ kPa}} \right)^{0.4/1.4} = 706.1 \text{ K}$$

$$\eta_C = \frac{h_{2s} - h_1}{h_2 - h_1} = \frac{c_p(T_{2s} - T_1)}{c_p(T_2 - T_1)} \longrightarrow T_2 = T_1 + \frac{T_{2s} - T_1}{\eta_C}$$

$$= 300 + \frac{706.1 - 300}{0.80} = 807.6 \text{ K}$$

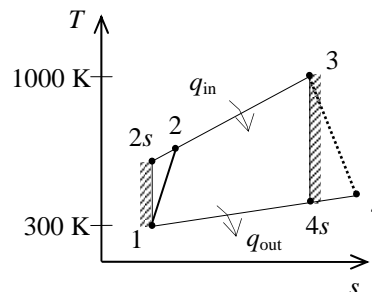

For the expansion process,

$$T_{4s} = T_3 \left(\frac{P_4}{P_3} \right)^{(k-1)/k} = (1000 \text{ K}) \left(\frac{100 \text{ kPa}}{1950 \text{ kPa}} \right)^{0.4/1.4} = 428.0 \text{ K}$$

$$\eta_T = \frac{h_3 - h_4}{h_3 - h_{4s}} = \frac{c_p(T_3 - T_4)}{c_p(T_3 - T_{4s})} \longrightarrow T_4 = T_3 - \eta_T(T_3 - T_{4s})$$

$$= 1000 - (0.90)(1000 - 428.0)$$

$$= 485.2 \text{ K}$$

Applying the first law to the constant-pressure heat addition process 2-3 produces

$$Q_{in} = m(h_3 - h_2) = mc_p(T_3 - T_2) = (1 \text{ kg})(1.005 \text{ kJ/kg}\cdot\text{K})(1000 - 807.6) \text{ K} = 193.4 \text{ kJ}$$

Similarly,

$$Q_{out} = m(h_4 - h_1) = mc_p(T_4 - T_1) = (1 \text{ kg})(1.005 \text{ kJ/kg}\cdot\text{K})(485.2 - 300) \text{ K} = 186.1 \text{ kJ}$$

The net work production is then

$$W_{net} = Q_{in} - Q_{out} = 193.4 - 186.1 = \mathbf{7.3 \text{ kJ}}$$

and the thermal efficiency of this cycle is

$$\eta_{th} = \frac{W_{net}}{Q_{in}} = \frac{7.3 \text{ kJ}}{193.4 \text{ kJ}} = \mathbf{0.0377}$$

9-98 A gas turbine power plant that operates on the simple Brayton cycle with air as the working fluid has a specified pressure ratio. The required mass flow rate of air is to be determined for two cases.

Assumptions 1 Steady operating conditions exist. 2 The air-standard assumptions are applicable. 3 Kinetic and potential energy changes are negligible. 4 Air is an ideal gas with constant specific heats.

Properties The properties of air at room temperature are $c_p = 1.005 \text{ kJ/kg}\cdot\text{K}$ and $k = 1.4$ (Table A-2).

Analysis (a) Using the isentropic relations,

$$T_{2s} = T_1 \left(\frac{P_2}{P_1} \right)^{(k-1)/k} = (300 \text{ K})(12)^{0.4/1.4} = 610.2 \text{ K}$$

$$T_{4s} = T_3 \left(\frac{P_4}{P_3} \right)^{(k-1)/k} = (1000 \text{ K}) \left(\frac{1}{12} \right)^{0.4/1.4} = 491.7 \text{ K}$$

$$w_{s,C,in} = h_{2s} - h_1 = c_p (T_{2s} - T_1) = (1.005 \text{ kJ/kg}\cdot\text{K})(610.2 - 300)\text{K} = 311.75 \text{ kJ/kg}$$

$$w_{s,T,out} = h_3 - h_{4s} = c_p (T_3 - T_{4s}) = (1.005 \text{ kJ/kg}\cdot\text{K})(1000 - 491.7)\text{K} = 510.84 \text{ kJ/kg}$$

$$w_{s,net,out} = w_{s,T,out} - w_{s,C,in} = 510.84 - 311.75 = 199.1 \text{ kJ/kg}$$

$$\dot{m}_s = \frac{\dot{W}_{net,out}}{w_{s,net,out}} = \frac{70,000 \text{ kJ/s}}{199.1 \text{ kJ/kg}} = \mathbf{352 \text{ kg/s}}$$

(b) The net work output is determined to be

$$w_{a,net,out} = w_{a,T,out} - w_{a,C,in} = \eta_T w_{s,T,out} - w_{s,C,in} / \eta_C$$

$$= (0.85)(510.84) - 311.75/0.85 = 67.5 \text{ kJ/kg}$$

$$\dot{m}_a = \frac{\dot{W}_{net,out}}{w_{a,net,out}} = \frac{70,000 \text{ kJ/s}}{67.5 \text{ kJ/kg}} = \mathbf{1037 \text{ kg/s}}$$

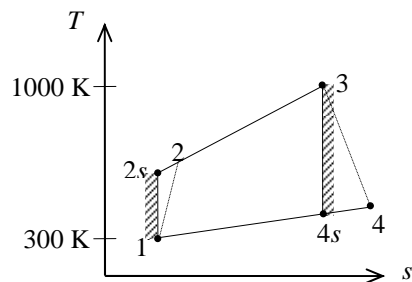

9-99 A stationary gas-turbine power plant operates on a simple ideal Brayton cycle with air as the working fluid. The power delivered by this plant is to be determined assuming constant and variable specific heats.

Assumptions 1 Steady operating conditions exist. 2 The air-standard assumptions are applicable. 3 Kinetic and potential energy changes are negligible. 4 Air is an ideal gas.

Analysis (a) Assuming constant specific heats,

$$T_{2s} = T_1 \left(\frac{P_2}{P_1} \right)^{(k-1)/k} = (290 \text{ K})(8)^{0.4/1.4} = 525.3 \text{ K}$$

$$T_{4s} = T_3 \left(\frac{P_4}{P_3} \right)^{(k-1)/k} = (1100 \text{ K}) \left(\frac{1}{8} \right)^{0.4/1.4} = 607.2 \text{ K}$$

$$\eta_{\text{th}} = 1 - \frac{q_{\text{out}}}{q_{\text{in}}} = 1 - \frac{c_p(T_4 - T_1)}{c_p(T_3 - T_2)} = 1 - \frac{T_4 - T_1}{T_3 - T_2} = 1 - \frac{607.2 - 290}{1100 - 525.3} = 0.448$$

$$\dot{W}_{\text{net,out}} = \eta_{\text{th}} \dot{Q}_{\text{in}} = (0.448)(35,000 \text{ kW}) = \mathbf{15,680 \text{ kW}}$$

(b) Assuming variable specific heats (Table A-17),

$$T_1 = 290 \text{ K} \longrightarrow \begin{aligned} h_1 &= 290.16 \text{ kJ/kg} \\ P_{r_1} &= 1.2311 \end{aligned}$$

$$P_{r_2} = \frac{P_2}{P_1} P_{r_1} = (8)(1.2311) = 9.8488 \longrightarrow h_2 = 526.12 \text{ kJ/kg}$$

$$T_3 = 1100 \text{ K} \longrightarrow \begin{aligned} h_3 &= 1161.07 \text{ kJ/kg} \\ P_{r_3} &= 167.1 \end{aligned}$$

$$P_{r_4} = \frac{P_4}{P_3} P_{r_3} = \left(\frac{1}{8} \right) (167.1) = 20.89 \longrightarrow h_4 = 651.37 \text{ kJ/kg}$$

$$\eta_{\text{th}} = 1 - \frac{q_{\text{out}}}{q_{\text{in}}} = 1 - \frac{h_4 - h_1}{h_3 - h_2} = 1 - \frac{651.37 - 290.16}{1161.07 - 526.11} = 0.431$$

$$\dot{W}_{\text{net,out}} = \eta_T \dot{Q}_{\text{in}} = (0.431)(35,000 \text{ kW}) = \mathbf{15,085 \text{ kW}}$$

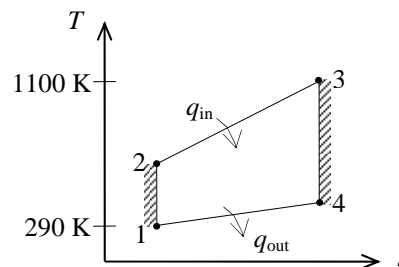

9-100 An actual gas-turbine power plant operates at specified conditions. The fraction of the turbine work output used to drive the compressor and the thermal efficiency are to be determined.

Assumptions 1 Steady operating conditions exist. 2 The air-standard assumptions are applicable. 3 Kinetic and potential energy changes are negligible. 4 Air is an ideal gas with variable specific heats.

Properties The properties of air are given in Table A-17.

Analysis (a) Using the isentropic relations,

$$T_1 = 300 \text{ K} \longrightarrow h_1 = 300.19 \text{ kJ/kg}$$

$$T_2 = 580 \text{ K} \longrightarrow h_2 = 586.04 \text{ kJ/kg}$$

$$r_p = \frac{P_2}{P_1} = \frac{700}{100} = 7$$

$$q_{\text{in}} = h_3 - h_2 \longrightarrow h_3 = 950 + 586.04 = 1536.04 \text{ kJ/kg}$$

$$\rightarrow P_{r_3} = 474.11$$

$$P_{r_4} = \frac{P_4}{P_3} P_{r_3} = \left(\frac{1}{7}\right)(474.11) = 67.73 \longrightarrow h_{4s} = 905.83 \text{ kJ/kg}$$

$$w_{\text{C,in}} = h_2 - h_1 = 586.04 - 300.19 = 285.85 \text{ kJ/kg}$$

$$w_{\text{T,out}} = \eta_T (h_3 - h_{4s}) = (0.86)(1536.04 - 905.83) = 542.0 \text{ kJ/kg}$$

Thus,

$$r_{\text{bw}} = \frac{w_{\text{C,in}}}{w_{\text{T,out}}} = \frac{285.85 \text{ kJ/kg}}{542.0 \text{ kJ/kg}} = \mathbf{52.7\%}$$

(b) $w_{\text{net,out}} = w_{\text{T,out}} - w_{\text{C,in}} = 542.0 - 285.85 = 256.15 \text{ kJ/kg}$

$$\eta_{\text{th}} = \frac{w_{\text{net,out}}}{q_{\text{in}}} = \frac{256.15 \text{ kJ/kg}}{950 \text{ kJ/kg}} = \mathbf{27.0\%}$$

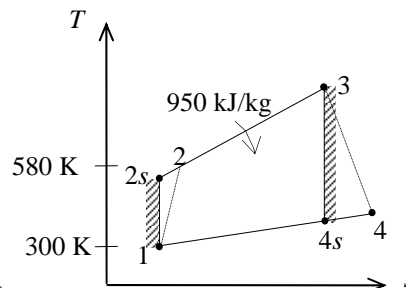

9-101 A gas-turbine power plant operates at specified conditions. The fraction of the turbine work output used to drive the compressor and the thermal efficiency are to be determined.

Assumptions 1 Steady operating conditions exist. 2 The air-standard assumptions are applicable. 3 Kinetic and potential energy changes are negligible. 4 Air is an ideal gas with constant specific heats.

Properties The properties of air at room temperature are $c_p = 1.005 \text{ kJ/kg}\cdot\text{K}$ and $k = 1.4$ (Table A-2).

Analysis (a) Using constant specific heats,

$$r_p = \frac{P_2}{P_1} = \frac{700}{100} = 7$$

$$\begin{aligned} q_{\text{in}} = h_3 - h_2 = c_p(T_3 - T_2) &\longrightarrow T_3 = T_2 + q_{\text{in}}/c_p \\ &= 580 \text{ K} + (950 \text{ kJ/kg})/(1.005 \text{ kJ/kg}\cdot\text{K}) \\ &= 1525.3 \text{ K} \end{aligned}$$

$$T_{4s} = T_3 \left(\frac{P_4}{P_3} \right)^{(k-1)/k} = (1525.3 \text{ K}) \left(\frac{1}{7} \right)^{0.4/1.4} = 874.8 \text{ K}$$

$$w_{\text{C,in}} = h_2 - h_1 = c_p(T_2 - T_1) = (1.005 \text{ kJ/kg}\cdot\text{K})(580 - 300) \text{ K} = 281.4 \text{ kJ/kg}$$

$$w_{\text{T,out}} = \eta_T(h_3 - h_{4s}) = \eta_T c_p(T_3 - T_{4s}) = (0.86)(1.005 \text{ kJ/kg}\cdot\text{K})(1525.3 - 874.8) \text{ K} = 562.2 \text{ kJ/kg}$$

Thus,

$$r_{\text{bw}} = \frac{w_{\text{C,in}}}{w_{\text{T,out}}} = \frac{281.4 \text{ kJ/kg}}{562.2 \text{ kJ/kg}} = \mathbf{50.1\%}$$

(b) $w_{\text{net,out}} = w_{\text{T,out}} - w_{\text{C,in}} = 562.2 - 281.4 = 280.8 \text{ kJ/kg}$

$$\eta_{\text{th}} = \frac{w_{\text{net,out}}}{q_{\text{in}}} = \frac{280.8 \text{ kJ/kg}}{950 \text{ kJ/kg}} = \mathbf{29.6\%}$$

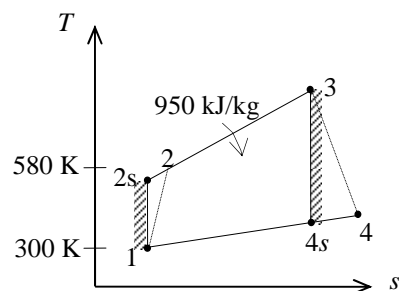

9-102E A simple ideal Brayton cycle with argon as the working fluid operates between the specified temperature and pressure limits. The rate of heat addition, the power produced, and the thermal efficiency are to be determined.

Assumptions 1 Steady operating conditions exist. 2 Kinetic and potential energy changes are negligible. 3 Argon is an ideal gas with constant specific heats.

Properties The properties of argon at room temperature are $R = 0.2686 \text{ psia}\cdot\text{ft}^3/\text{lbm}\cdot\text{R}$ (Table A-1E), $c_p = 0.1253 \text{ Btu}/\text{lbm}\cdot\text{R}$ and $k = 1.667$ (Table A-2Ea).

Analysis At the compressor inlet,

$$\nu_1 = \frac{RT_1}{P_1} = \frac{(0.2686 \text{ psia}\cdot\text{ft}^3/\text{lbm}\cdot\text{R})(540 \text{ R})}{15 \text{ psia}} = 9.670 \text{ ft}^3/\text{lbm}$$

$$\dot{m} = \frac{A_1 V_1}{\nu_1} = \frac{(3 \text{ ft}^2)(200 \text{ ft/s})}{9.670 \text{ ft}^3/\text{lbm}} = 62.05 \text{ lbm/s}$$

According to the isentropic process expressions for an ideal gas,

$$T_2 = T_1 \left(\frac{P_2}{P_1} \right)^{(k-1)/k} = (540 \text{ R}) \left(\frac{150 \text{ psia}}{15 \text{ psia}} \right)^{0.667/1.667} = 1357 \text{ R}$$

$$T_4 = T_3 \left(\frac{P_4}{P_3} \right)^{(k-1)/k} = (1660 \text{ R}) \left(\frac{15 \text{ psia}}{150 \text{ psia}} \right)^{0.667/1.667} = 660.7 \text{ R}$$

Applying the first law to the constant-pressure heat addition process 2-3 gives

$$\dot{Q}_{\text{in}} = \dot{m} c_p (T_3 - T_2) = (62.05 \text{ lbm/s})(0.1253 \text{ Btu}/\text{lbm}\cdot\text{R})(1660 - 1357) \text{ R} = \mathbf{2356 \text{ Btu/s}}$$

The net power output is

$$\begin{aligned} \dot{W}_{\text{net}} &= \dot{m} c_p (T_3 - T_4 + T_1 - T_2) \\ &= (62.05 \text{ lbm/s})(0.1253 \text{ Btu}/\text{lbm}\cdot\text{R})(1660 - 660.7 + 540 - 1357) \text{ R} \\ &= \mathbf{1417 \text{ Btu/s}} \end{aligned}$$

The thermal efficiency of this cycle is then

$$\eta_{\text{th}} = \frac{\dot{W}_{\text{net}}}{\dot{Q}_{\text{in}}} = \frac{1417 \text{ Btu/s}}{2356 \text{ Btu/s}} = \mathbf{0.601}$$

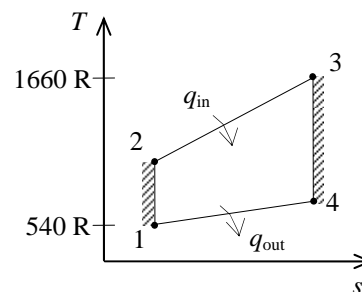

9-103 An aircraft engine operates as a simple ideal Brayton cycle with air as the working fluid. The pressure ratio and the rate of heat input are given. The net power and the thermal efficiency are to be determined.

Assumptions 1 Steady operating conditions exist. 2 The air-standard assumptions are applicable. 3 Kinetic and potential energy changes are negligible. 4 Air is an ideal gas with constant specific heats.

Properties The properties of air at room temperature are $c_p = 1.005 \text{ kJ/kg}\cdot\text{K}$ and $k = 1.4$ (Table A-2a).

Analysis For the isentropic compression process,

$$T_2 = T_1 r_p^{(k-1)/k} = (273 \text{ K})(10)^{0.4/1.4} = 527.1 \text{ K}$$

The heat addition is

$$q_{\text{in}} = \frac{\dot{Q}_{\text{in}}}{\dot{m}} = \frac{500 \text{ kW}}{1 \text{ kg/s}} = 500 \text{ kJ/kg}$$

Applying the first law to the heat addition process,

$$q_{\text{in}} = c_p (T_3 - T_2)$$

$$T_3 = T_2 + \frac{q_{\text{in}}}{c_p} = 527.1 \text{ K} + \frac{500 \text{ kJ/kg}}{1.005 \text{ kJ/kg}\cdot\text{K}} = 1025 \text{ K}$$

The temperature at the exit of the turbine is

$$T_4 = T_3 \left(\frac{1}{r_p} \right)^{(k-1)/k} = (1025 \text{ K}) \left(\frac{1}{10} \right)^{0.4/1.4} = 530.9 \text{ K}$$

Applying the first law to the adiabatic turbine and the compressor produce

$$w_T = c_p (T_3 - T_4) = (1.005 \text{ kJ/kg}\cdot\text{K})(1025 - 530.9) \text{ K} = 496.6 \text{ kJ/kg}$$

$$w_C = c_p (T_2 - T_1) = (1.005 \text{ kJ/kg}\cdot\text{K})(527.1 - 273) \text{ K} = 255.4 \text{ kJ/kg}$$

The net power produced by the engine is then

$$\dot{W}_{\text{net}} = \dot{m}(w_T - w_C) = (1 \text{ kg/s})(496.6 - 255.4) \text{ kJ/kg} = \mathbf{241.2 \text{ kW}}$$

Finally the thermal efficiency is

$$\eta_{\text{th}} = \frac{\dot{W}_{\text{net}}}{\dot{Q}_{\text{in}}} = \frac{241.2 \text{ kW}}{500 \text{ kW}} = \mathbf{0.482}$$

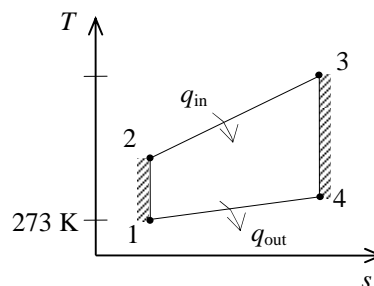

9-104 An aircraft engine operates as a simple ideal Brayton cycle with air as the working fluid. The pressure ratio and the rate of heat input are given. The net power and the thermal efficiency are to be determined.

Assumptions 1 Steady operating conditions exist. 2 The air-standard assumptions are applicable. 3 Kinetic and potential energy changes are negligible. 4 Air is an ideal gas with constant specific heats.

Properties The properties of air at room temperature are $c_p = 1.005 \text{ kJ/kg}\cdot\text{K}$ and $k = 1.4$ (Table A-2a).

Analysis For the isentropic compression process,

$$T_2 = T_1 r_p^{(k-1)/k} = (273 \text{ K})(15)^{0.4/1.4} = 591.8 \text{ K}$$

The heat addition is

$$q_{\text{in}} = \frac{\dot{Q}_{\text{in}}}{\dot{m}} = \frac{500 \text{ kW}}{1 \text{ kg/s}} = 500 \text{ kJ/kg}$$

Applying the first law to the heat addition process,

$$q_{\text{in}} = c_p (T_3 - T_2)$$

$$T_3 = T_2 + \frac{q_{\text{in}}}{c_p} = 591.8 \text{ K} + \frac{500 \text{ kJ/kg}}{1.005 \text{ kJ/kg}\cdot\text{K}} = 1089 \text{ K}$$

The temperature at the exit of the turbine is

$$T_4 = T_3 \left(\frac{1}{r_p} \right)^{(k-1)/k} = (1089 \text{ K}) \left(\frac{1}{15} \right)^{0.4/1.4} = 502.3 \text{ K}$$

Applying the first law to the adiabatic turbine and the compressor produce

$$w_T = c_p (T_3 - T_4) = (1.005 \text{ kJ/kg}\cdot\text{K})(1089 - 502.3) \text{ K} = 589.6 \text{ kJ/kg}$$

$$w_C = c_p (T_2 - T_1) = (1.005 \text{ kJ/kg}\cdot\text{K})(591.8 - 273) \text{ K} = 320.4 \text{ kJ/kg}$$

The net power produced by the engine is then

$$\dot{W}_{\text{net}} = \dot{m}(w_T - w_C) = (1 \text{ kg/s})(589.6 - 320.4) \text{ kJ/kg} = \mathbf{269.2 \text{ kW}}$$

Finally the thermal efficiency is

$$\eta_{\text{th}} = \frac{\dot{W}_{\text{net}}}{\dot{Q}_{\text{in}}} = \frac{269.2 \text{ kW}}{500 \text{ kW}} = \mathbf{0.538}$$

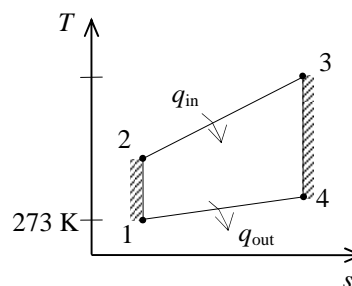

9-105 A gas-turbine plant operates on the simple Brayton cycle. The net power output, the back work ratio, and the thermal efficiency are to be determined.

Assumptions 1 The air-standard assumptions are applicable. **2** Kinetic and potential energy changes are negligible. **3** Air is an ideal gas with variable specific heats.

Properties The gas constant of air is $R = 0.287 \text{ kJ/kg}\cdot\text{K}$ (Table A-1).

Analysis (a) For this problem, we use the properties from EES software. Remember that for an ideal gas, enthalpy is a function of temperature only whereas entropy is functions of both temperature and pressure.

Process 1-2: Compression

$$T_1 = 30^\circ\text{C} \longrightarrow h_1 = 303.60 \text{ kJ/kg}$$

$$\left. \begin{array}{l} T_1 = 30^\circ\text{C} \\ P_1 = 100 \text{ kPa} \end{array} \right\} s_1 = 5.7159 \text{ kJ/kg}\cdot\text{K}$$

$$\left. \begin{array}{l} P_2 = 1200 \text{ kPa} \\ s_2 = s_1 = 5.7159 \text{ kJ/kg}\cdot\text{K} \end{array} \right\} h_{2s} = 617.37 \text{ kJ/kg}$$

$$\eta_C = \frac{h_{2s} - h_1}{h_2 - h_1} \longrightarrow 0.82 = \frac{617.37 - 303.60}{h_2 - 303.60} \longrightarrow h_2 = 686.24 \text{ kJ/kg}$$

Process 3-4: Expansion

$$T_4 = 500^\circ\text{C} \longrightarrow h_4 = 792.62 \text{ kJ/kg}$$

$$\eta_T = \frac{h_3 - h_4}{h_3 - h_{4s}} \longrightarrow 0.88 = \frac{h_3 - 792.62}{h_3 - h_{4s}}$$

We cannot find the enthalpy at state 3 directly. However, using the following lines in EES together with the isentropic efficiency relation, we find $h_3 = 1404.7 \text{ kJ/kg}$, $T_3 = 1034^\circ\text{C}$, $s_3 = 6.5699 \text{ kJ/kg}\cdot\text{K}$. The solution by hand would require a trial-error approach.

$$h_3 = \text{enthalpy}(\text{Air}, T=T_3)$$

$$s_3 = \text{entropy}(\text{Air}, T=T_3, P=P_2)$$

$$h_4s = \text{enthalpy}(\text{Air}, P=P_1, s=s_3)$$

The mass flow rate is determined from

$$\dot{m} = \frac{P_1 \dot{V}_1}{RT_1} = \frac{(100 \text{ kPa})(150/60 \text{ m}^3/\text{s})}{(0.287 \text{ kPa}\cdot\text{m}^3/\text{kg}\cdot\text{K})(30 + 273 \text{ K})} = 2.875 \text{ kg/s}$$

The net power output is

$$\dot{W}_{C,\text{in}} = \dot{m}(h_2 - h_1) = (2.875 \text{ kg/s})(686.24 - 303.60) \text{ kJ/kg} = 1100 \text{ kW}$$

$$\dot{W}_{T,\text{out}} = \dot{m}(h_3 - h_4) = (2.875 \text{ kg/s})(1404.7 - 792.62) \text{ kJ/kg} = 1759 \text{ kW}$$

$$\dot{W}_{\text{net}} = \dot{W}_{T,\text{out}} - \dot{W}_{C,\text{in}} = 1759 - 1100 = \mathbf{659 \text{ kW}}$$

(b) The back work ratio is

$$r_{\text{bw}} = \frac{\dot{W}_{C,\text{in}}}{\dot{W}_{T,\text{out}}} = \frac{1100 \text{ kW}}{1759 \text{ kW}} = \mathbf{0.625}$$

(c) The rate of heat input and the thermal efficiency are

$$\dot{Q}_{\text{in}} = \dot{m}(h_3 - h_2) = (2.875 \text{ kg/s})(1404.7 - 686.24) \text{ kJ/kg} = 2065 \text{ kW}$$

$$\eta_{\text{th}} = \frac{\dot{W}_{\text{net}}}{\dot{Q}_{\text{in}}} = \frac{659 \text{ kW}}{2065 \text{ kW}} = \mathbf{0.319}$$

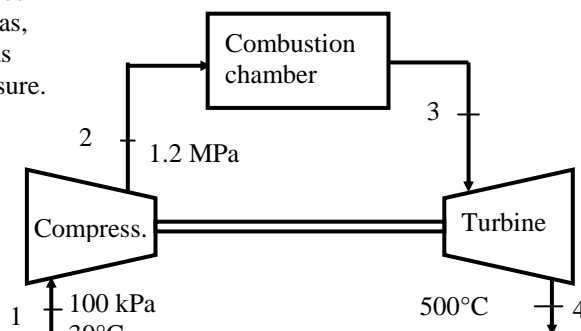

Brayton Cycle with Regeneration

9-106C Regeneration increases the thermal efficiency of a Brayton cycle by capturing some of the waste heat from the exhaust gases and preheating the air before it enters the combustion chamber.

9-107C Yes. At very high compression ratios, the gas temperature at the turbine exit may be lower than the temperature at the compressor exit. Therefore, if these two streams are brought into thermal contact in a regenerator, heat will flow to the exhaust gases instead of from the exhaust gases. As a result, the thermal efficiency will decrease.

9-108C The extent to which a regenerator approaches an ideal regenerator is called the effectiveness ε , and is defined as $\varepsilon = q_{\text{regen, act}} / q_{\text{regen, max}}$.

9-109C (b) turbine exit.

9-110C The steam injected increases the mass flow rate through the turbine and thus the power output. This, in turn, increases the thermal efficiency since $\eta = W / Q_{\text{in}}$ and W increases while Q_{in} remains constant. Steam can be obtained by utilizing the hot exhaust gases.

9-111 A Brayton cycle with regeneration produces 150 kW power. The rates of heat addition and rejection are to be determined.

Assumptions 1 The air standard assumptions are applicable. **2** Air is an ideal gas with constant specific heats at room temperature. **3** Kinetic and potential energy changes are negligible.

Properties The properties of air at room temperature are $c_p = 1.005 \text{ kJ/kg}\cdot\text{K}$ and $k = 1.4$ (Table A-2a).

Analysis According to the isentropic process expressions for an ideal gas,

$$T_2 = T_1 r_p^{(k-1)/k} = (293 \text{ K})(8)^{0.4/1.4} = 530.8 \text{ K}$$

$$T_5 = T_4 \left(\frac{1}{r_p} \right)^{(k-1)/k} = (1073 \text{ K}) \left(\frac{1}{8} \right)^{0.4/1.4} = 592.3 \text{ K}$$

When the first law is applied to the heat exchanger, the result is

$$T_3 - T_2 = T_5 - T_6$$

while the regenerator temperature specification gives

$$T_3 = T_5 - 10 = 592.3 - 10 = 582.3 \text{ K}$$

The simultaneous solution of these two results gives

$$T_6 = T_5 - (T_3 - T_2) = 592.3 - (582.3 - 530.8) = 540.8 \text{ K}$$

Application of the first law to the turbine and compressor gives

$$\begin{aligned} w_{\text{net}} &= c_p(T_4 - T_5) - c_p(T_2 - T_1) \\ &= (1.005 \text{ kJ/kg}\cdot\text{K})(1073 - 592.3) \text{ K} - (1.005 \text{ kJ/kg}\cdot\text{K})(530.8 - 293) \text{ K} \\ &= 244.1 \text{ kJ/kg} \end{aligned}$$

Then,

$$\dot{m} = \frac{\dot{W}_{\text{net}}}{w_{\text{net}}} = \frac{150 \text{ kW}}{244.1 \text{ kJ/kg}} = 0.6145 \text{ kg/s}$$

Applying the first law to the combustion chamber produces

$$\dot{Q}_{\text{in}} = \dot{m} c_p (T_4 - T_3) = (0.6145 \text{ kg/s})(1.005 \text{ kJ/kg}\cdot\text{K})(1073 - 582.3) \text{ K} = \mathbf{303.0 \text{ kW}}$$

Similarly,

$$\dot{Q}_{\text{out}} = \dot{m} c_p (T_6 - T_1) = (0.6145 \text{ kg/s})(1.005 \text{ kJ/kg}\cdot\text{K})(540.8 - 293) \text{ K} = \mathbf{153.0 \text{ kW}}$$

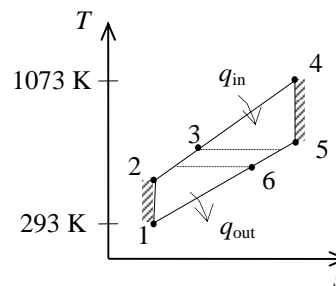

9-112 A Brayton cycle with regeneration produces 150 kW power. The rates of heat addition and rejection are to be determined.

Assumptions 1 The air standard assumptions are applicable. **2** Air is an ideal gas with constant specific heats at room temperature. **3** Kinetic and potential energy changes are negligible.

Properties The properties of air at room temperature are $c_p = 1.005 \text{ kJ/kg}\cdot\text{K}$ and $k = 1.4$ (Table A-2a).

Analysis For the compression and expansion processes we have

$$T_{2s} = T_1 r_p^{(k-1)/k} = (293 \text{ K})(8)^{0.4/1.4} = 530.8 \text{ K}$$

$$\eta_C = \frac{c_p(T_{2s} - T_1)}{c_p(T_2 - T_1)} \longrightarrow T_2 = T_1 + \frac{T_{2s} - T_1}{\eta_C}$$

$$= 293 + \frac{530.8 - 293}{0.87} = 566.3 \text{ K}$$

$$T_{5s} = T_4 \left(\frac{1}{r_p} \right)^{(k-1)/k} = (1073 \text{ K}) \left(\frac{1}{8} \right)^{0.4/1.4} = 592.3 \text{ K}$$

$$\eta_T = \frac{c_p(T_4 - T_5)}{c_p(T_4 - T_{5s})} \longrightarrow T_5 = T_4 - \eta_T(T_4 - T_{5s})$$

$$= 1073 - (0.93)(1073 - 592.3)$$

$$= 625.9 \text{ K}$$

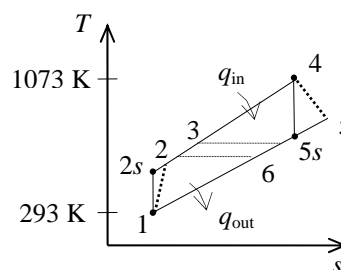

When the first law is applied to the heat exchanger, the result is

$$T_3 - T_2 = T_5 - T_6$$

while the regenerator temperature specification gives

$$T_3 = T_5 - 10 = 625.9 - 10 = 615.9 \text{ K}$$

The simultaneous solution of these two results gives

$$T_6 = T_5 - (T_3 - T_2) = 625.9 - (615.9 - 566.3) = 576.3 \text{ K}$$

Application of the first law to the turbine and compressor gives

$$w_{\text{net}} = c_p(T_4 - T_5) - c_p(T_2 - T_1)$$

$$= (1.005 \text{ kJ/kg}\cdot\text{K})(1073 - 625.9) \text{ K} - (1.005 \text{ kJ/kg}\cdot\text{K})(566.3 - 293) \text{ K}$$

$$= 174.7 \text{ kJ/kg}$$

Then,

$$\dot{m} = \frac{\dot{W}_{\text{net}}}{w_{\text{net}}} = \frac{150 \text{ kW}}{174.7 \text{ kJ/kg}} = 0.8586 \text{ kg/s}$$

Applying the first law to the combustion chamber produces

$$\dot{Q}_{\text{in}} = \dot{m} c_p (T_4 - T_3) = (0.8586 \text{ kg/s})(1.005 \text{ kJ/kg}\cdot\text{K})(1073 - 615.9) \text{ K} = \mathbf{394.4 \text{ kW}}$$

Similarly,

$$\dot{Q}_{\text{out}} = \dot{m} c_p (T_6 - T_1) = (0.8586 \text{ kg/s})(1.005 \text{ kJ/kg}\cdot\text{K})(576.3 - 293) \text{ K} = \mathbf{244.5 \text{ kW}}$$

9-113 A Brayton cycle with regeneration is considered. The thermal efficiencies of the cycle for parallel-flow and counter-flow arrangements of the regenerator are to be compared.

Assumptions 1 The air standard assumptions are applicable. **2** Air is an ideal gas with constant specific heats at room temperature. **3** Kinetic and potential energy changes are negligible.

Properties The properties of air at room temperature are $c_p = 1.005$ kJ/kg·K and $k = 1.4$ (Table A-2a).

Analysis According to the isentropic process expressions for an ideal gas,

$$T_2 = T_1 r_p^{(k-1)/k} = (293 \text{ K})(7)^{0.4/1.4} = 510.9 \text{ K}$$

$$T_5 = T_4 \left(\frac{1}{r_p} \right)^{(k-1)/k} = (1000 \text{ K}) \left(\frac{1}{7} \right)^{0.4/1.4} = 573.5 \text{ K}$$

When the first law is applied to the heat exchanger as originally arranged, the result is

$$T_3 - T_2 = T_5 - T_6$$

while the regenerator temperature specification gives

$$T_3 = T_5 - 6 = 573.5 - 6 = 567.5 \text{ K}$$

The simultaneous solution of these two results gives

$$T_6 = T_5 - T_3 + T_2 = 573.5 - 567.5 + 510.9 = 516.9 \text{ K}$$

The thermal efficiency of the cycle is then

$$\eta_{\text{th}} = 1 - \frac{q_{\text{out}}}{q_{\text{in}}} = 1 - \frac{T_6 - T_1}{T_4 - T_3} = 1 - \frac{516.9 - 293}{1000 - 567.5} = \mathbf{0.482}$$

For the rearranged version of this cycle,

$$T_3 = T_6 - 6$$

An energy balance on the heat exchanger gives

$$T_3 - T_2 = T_5 - T_6$$

The solution of these two equations is

$$T_3 = 539.2 \text{ K}$$

$$T_6 = 545.2 \text{ K}$$

The thermal efficiency of the cycle is then

$$\eta_{\text{th}} = 1 - \frac{q_{\text{out}}}{q_{\text{in}}} = 1 - \frac{T_6 - T_1}{T_4 - T_3} = 1 - \frac{545.2 - 293}{1000 - 539.2} = \mathbf{0.453}$$

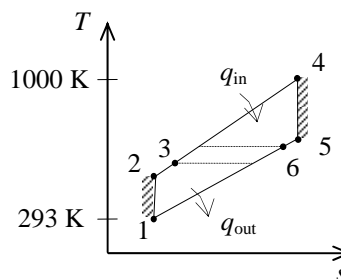
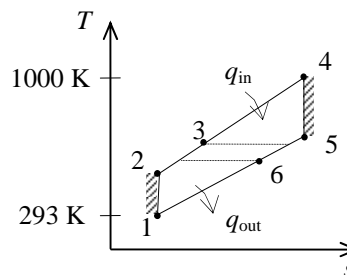

9-114E An ideal Brayton cycle with regeneration has a pressure ratio of 8. The thermal efficiency of the cycle is to be determined with and without regenerator cases.

Assumptions 1 The air standard assumptions are applicable. **2** Air is an ideal gas with constant specific heats at room temperature. **3** Kinetic and potential energy changes are negligible.

Properties The properties of air at room temperature are $c_p = 0.24$ Btu/lbm·R and $k = 1.4$ (Table A-2Ea).

Analysis According to the isentropic process expressions for an ideal gas,

$$T_2 = T_1 r_p^{(k-1)/k} = (510 \text{ R})(8)^{0.4/1.4} = 923.8 \text{ R}$$

$$T_5 = T_4 \left(\frac{1}{r_p} \right)^{(k-1)/k} = (1960 \text{ R}) \left(\frac{1}{8} \right)^{0.4/1.4} = 1082 \text{ R}$$

The regenerator is ideal (i.e., the effectiveness is 100%) and thus,

$$T_3 = T_5 = 1082 \text{ R}$$

$$T_6 = T_2 = 923.8 \text{ R}$$

The thermal efficiency of the cycle is then

$$\eta_{\text{th}} = 1 - \frac{q_{\text{out}}}{q_{\text{in}}} = 1 - \frac{T_6 - T_1}{T_4 - T_3} = 1 - \frac{923.8 - 510}{1960 - 1082} = \mathbf{0.529}$$

The solution without a regenerator is as follows:

$$T_2 = T_1 r_p^{(k-1)/k} = (510 \text{ R})(8)^{0.4/1.4} = 923.8 \text{ R}$$

$$T_4 = T_3 \left(\frac{1}{r_p} \right)^{(k-1)/k} = (1960 \text{ R}) \left(\frac{1}{8} \right)^{0.4/1.4} = 1082 \text{ R}$$

$$\eta_{\text{th}} = 1 - \frac{q_{\text{out}}}{q_{\text{in}}} = 1 - \frac{T_4 - T_1}{T_3 - T_2} = 1 - \frac{1082 - 510}{1960 - 923.8} = \mathbf{0.448}$$

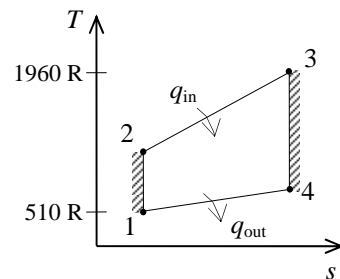
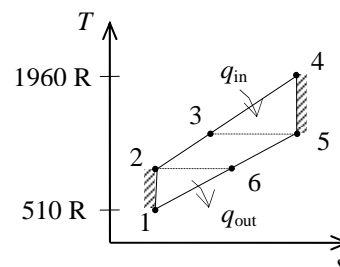

9-115 An expression for the thermal efficiency of an ideal Brayton cycle with an ideal regenerator is to be developed.

Assumptions 1 The air standard assumptions are applicable. **2** Air is an ideal gas with constant specific heats at room temperature. **3** Kinetic and potential energy changes are negligible.

Analysis The expressions for the isentropic compression and expansion processes are

$$T_2 = T_1 r_p^{(k-1)/k}$$

$$T_4 = T_3 \left(\frac{1}{r_p} \right)^{(k-1)/k}$$

For an ideal regenerator,

$$T_5 = T_4$$

$$T_6 = T_2$$

The thermal efficiency of the cycle is

$$\begin{aligned} \eta_{\text{th}} &= 1 - \frac{q_{\text{out}}}{q_{\text{in}}} = 1 - \frac{T_6 - T_1}{T_3 - T_5} = 1 - \frac{T_1 (T_6 / T_1) - 1}{T_3 [1 - (T_5 / T_3)]} \\ &= 1 - \frac{T_1 (T_2 / T_1) - 1}{T_3 [1 - (T_4 / T_3)]} \\ &= 1 - \frac{T_1 r_p^{(k-1)/k} - 1}{T_3 [1 - r_p^{-(k-1)/k}]} \\ &= 1 - \frac{T_1}{T_3} r_p^{(k-1)/k} \end{aligned}$$

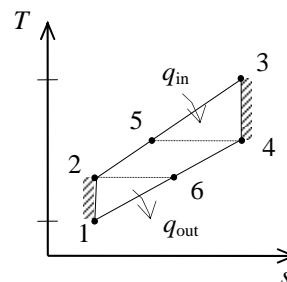

9-116E A car is powered by a gas turbine with a pressure ratio of 4. The thermal efficiency of the car and the mass flow rate of air for a net power output of 95 hp are to be determined.

Assumptions 1 Steady operating conditions exist. **2** Air is an ideal gas with variable specific heats. **3** The ambient air is 540 R and 14.5 psia. **4** The effectiveness of the regenerator is 0.9, and the isentropic efficiencies for both the compressor and the turbine are 80%. **5** The combustion gases can be treated as air.

Properties The properties of air at the compressor and turbine inlet temperatures can be obtained from Table A-17E.

Analysis The gas turbine cycle with regeneration can be analyzed as follows:

$$T_1 = 540 \text{ R} \longrightarrow \begin{matrix} h_1 = 129.06 \text{ Btu/lbm} \\ P_{r_1} = 1.386 \end{matrix}$$

$$P_{r_2} = \frac{P_2}{P_1} P_{r_1} = (4)(1.386) = 5.544 \longrightarrow h_{2s} = 192.0 \text{ Btu/lbm}$$

$$T_3 = 2160 \text{ R} \longrightarrow \begin{matrix} h_3 = 549.35 \text{ Btu/lbm} \\ P_{r_3} = 230.12 \end{matrix}$$

$$P_{r_4} = \frac{P_4}{P_3} P_{r_3} = \left(\frac{1}{4}\right)(230.12) = 57.53 \longrightarrow h_{4s} = 372.2 \text{ Btu/lbm}$$

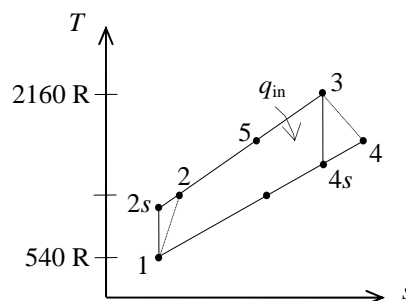

and

$$\eta_{\text{comp}} = \frac{h_{2s} - h_1}{h_2 - h_1} \rightarrow 0.80 = \frac{192.0 - 129.06}{h_2 - 129.06} \rightarrow h_2 = 207.74 \text{ Btu/lbm}$$

$$\eta_{\text{turb}} = \frac{h_3 - h_4}{h_3 - h_{4s}} \rightarrow 0.80 = \frac{549.35 - h_4}{549.35 - 372.2} \rightarrow h_4 = 407.63 \text{ Btu/lbm}$$

Then the thermal efficiency of the gas turbine cycle becomes

$$q_{\text{regen}} = \varepsilon(h_4 - h_2) = 0.9(407.63 - 207.74) = 179.9 \text{ Btu/lbm}$$

$$q_{\text{in}} = (h_3 - h_2) - q_{\text{regen}} = (549.35 - 207.74) - 179.9 = 161.7 \text{ Btu/lbm}$$

$$w_{\text{net,out}} = w_{\text{T,out}} - w_{\text{C,in}} = (h_3 - h_4) - (h_2 - h_1) = (549.35 - 407.63) - (207.74 - 129.06) = 63.0 \text{ Btu/lbm}$$

$$\eta_{\text{th}} = \frac{w_{\text{net,out}}}{q_{\text{in}}} = \frac{63.0 \text{ Btu/lbm}}{161.7 \text{ Btu/lbm}} = 0.39 = \mathbf{39\%}$$

Finally, the mass flow rate of air through the turbine becomes

$$\dot{m}_{\text{air}} = \frac{\dot{W}_{\text{net}}}{w_{\text{net}}} = \frac{95 \text{ hp}}{63.0 \text{ Btu/lbm}} \left(\frac{0.7068 \text{ Btu/s}}{1 \text{ hp}} \right) = \mathbf{1.07 \text{ lbm/s}}$$

9-117 [Also solved by EES on enclosed CD] The thermal efficiency and power output of an actual gas turbine are given. The isentropic efficiency of the turbine and of the compressor, and the thermal efficiency of the gas turbine modified with a regenerator are to be determined.

Assumptions 1 Air is an ideal gas with variable specific heats. **2** Kinetic and potential energy changes are negligible. **3** The mass flow rates of air and of the combustion gases are the same, and the properties of combustion gases are the same as those of air.

Properties The properties of air are given in Table A-17.

Analysis The properties at various states are

$$T_1 = 20^\circ\text{C} = 293 \text{ K} \longrightarrow \begin{matrix} h_1 = 293.2 \text{ kJ/kg} \\ P_{r_1} = 1.2765 \end{matrix}$$

$$P_{r_2} = \frac{P_2}{P_1} P_{r_1} = (14.7)(1.2765) = 18.765 \longrightarrow h_{2s} = 643.3 \text{ kJ/kg}$$

$$T_3 = 1288^\circ\text{C} = 1561 \text{ K} \longrightarrow \begin{matrix} h_3 = 1710.0 \text{ kJ/kg} \\ P_{r_3} = 712.5 \end{matrix}$$

$$P_{r_4} = \frac{P_4}{P_3} P_{r_3} = \left(\frac{1}{14.7}\right)(712.5) = 48.47 \longrightarrow h_{4s} = 825.23 \text{ kJ/kg}$$

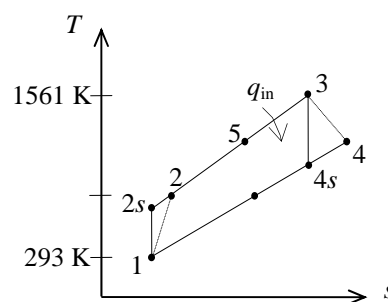

The net work output and the heat input per unit mass are

$$w_{\text{net}} = \frac{\dot{W}_{\text{net}}}{\dot{m}} = \frac{159,000 \text{ kW}}{1,536,000 \text{ kg/h}} \left(\frac{3600 \text{ s}}{1 \text{ h}} \right) = 372.66 \text{ kJ/kg}$$

$$q_{\text{in}} = \frac{w_{\text{net}}}{\eta_{\text{th}}} = \frac{372.66 \text{ kJ/kg}}{0.359} = 1038.0 \text{ kJ/kg}$$

$$q_{\text{in}} = h_3 - h_2 \rightarrow h_2 = h_3 - q_{\text{in}} = 1710 - 1038 = 672.0 \text{ kJ/kg}$$

$$q_{\text{out}} = q_{\text{in}} - w_{\text{net}} = 1038.0 - 372.66 = 665.34 \text{ kJ/kg}$$

$$q_{\text{out}} = h_4 - h_1 \rightarrow h_4 = q_{\text{out}} + h_1 = 665.34 + 293.2 = 958.54 \text{ kJ/kg} \rightarrow T_4 = 650^\circ\text{C}$$

Then the compressor and turbine efficiencies become

$$\eta_T = \frac{h_3 - h_4}{h_3 - h_{4s}} = \frac{1710 - 958.54}{1710 - 825.23} = \mathbf{0.849}$$

$$\eta_C = \frac{h_{2s} - h_1}{h_2 - h_1} = \frac{643.3 - 293.2}{672 - 293.2} = \mathbf{0.924}$$

When a regenerator is added, the new heat input and the thermal efficiency become

$$q_{\text{regen}} = \varepsilon(h_4 - h_2) = (0.80)(958.54 - 672.0) = 286.54 \text{ kJ/kg}$$

$$q_{\text{in,new}} = q_{\text{in}} - q_{\text{regen}} = 1038 - 286.54 = 751.46 \text{ kJ/kg}$$

$$\eta_{\text{th,new}} = \frac{w_{\text{net}}}{q_{\text{in,new}}} = \frac{372.66 \text{ kJ/kg}}{751.46 \text{ kJ/kg}} = \mathbf{0.496}$$

Discussion Note an 80% efficient regenerator would increase the thermal efficiency of this gas turbine from 35.9% to 49.6%.

9-118 EES Problem 9-117 is reconsidered. A solution that allows different isentropic efficiencies for the compressor and turbine is to be developed and the effect of the isentropic efficiencies on net work done and the heat supplied to the cycle is to be studied. Also, the T - s diagram for the cycle is to be plotted.

Analysis Using EES, the problem is solved as follows:

"Input data"

$$T[3] = 1288 \text{ [C]}$$

$$\text{Pratio} = 14.7$$

$$T[1] = 20 \text{ [C]}$$

$$P[1] = 100 \text{ [kPa]}$$

$$\{T[4]=589 \text{ [C]}\}$$

$$\{W_{\text{dot_net}}=159 \text{ [MW]}\} \text{ "We omit the information about the cycle net work"}$$

$$m_{\text{dot}} = 1536000 \text{ [kg/h]} * \text{Convert(kg/h,kg/s)}$$

$$\{\text{Eta_th_noreg}=0.359\} \text{ "We omit the information about the cycle efficiency."}$$

$$\text{Eta_reg} = 0.80$$

$$\text{Eta_c} = 0.892 \text{ "Compressor isentropic efficiency"}$$

$$\text{Eta_t} = 0.926 \text{ "Turbine isentropic efficiency"}$$

"Isentropic Compressor analysis"

$$s[1] = \text{ENTROPY}(\text{Air}, T=T[1], P=P[1])$$

$$s_{\text{s}}[2] = s[1] \text{ "For the ideal case the entropies are constant across the compressor"}$$

$$P[2] = \text{Pratio} * P[1]$$

$$s_{\text{s}}[2] = \text{ENTROPY}(\text{Air}, T=T_{\text{s}}[2], P=P[2])$$

$$T_{\text{s}}[2] \text{ is the isentropic value of } T[2] \text{ at compressor exit"}$$

$$\text{Eta_c} = W_{\text{dot_compisen}} / W_{\text{dot_comp}}$$

$$\text{"compressor adiabatic efficiency, } W_{\text{dot_comp}} > W_{\text{dot_compisen}} \text{"}$$

"Conservation of energy for the compressor for the isentropic case:

$$E_{\text{dot_in}} - E_{\text{dot_out}} = \text{DELTA}E_{\text{dot}} = 0 \text{ for steady-flow"}$$

$$m_{\text{dot}} * h[1] + W_{\text{dot_compisen}} = m_{\text{dot}} * h_{\text{s}}[2]$$

$$h[1] = \text{ENTHALPY}(\text{Air}, T=T[1])$$

$$h_{\text{s}}[2] = \text{ENTHALPY}(\text{Air}, T=T_{\text{s}}[2])$$

"Actual compressor analysis:"

$$m_{\text{dot}} * h[1] + W_{\text{dot_comp}} = m_{\text{dot}} * h[2]$$

$$h[2] = \text{ENTHALPY}(\text{Air}, T=T[2])$$

$$s[2] = \text{ENTROPY}(\text{Air}, T=T[2], P=P[2])$$

"External heat exchanger analysis"

"SSSF First Law for the heat exchanger, assuming $W=0$, $ke=pe=0$

$$E_{\text{dot_in}} - E_{\text{dot_out}} = \text{DELTA}E_{\text{dot_cv}} = 0 \text{ for steady flow"}$$

$$m_{\text{dot}} * h[2] + Q_{\text{dot_in_noreg}} = m_{\text{dot}} * h[3]$$

$$q_{\text{in_noreg}} = Q_{\text{dot_in_noreg}} / m_{\text{dot}}$$

$$h[3] = \text{ENTHALPY}(\text{Air}, T=T[3])$$

$$P[3] = P[2] \text{ "process 2-3 is SSSF constant pressure"}$$

"Turbine analysis"

$$s[3] = \text{ENTROPY}(\text{Air}, T=T[3], P=P[3])$$

$$s_{\text{s}}[4] = s[3] \text{ "For the ideal case the entropies are constant across the turbine"}$$

$$P[4] = P[3] / \text{Pratio}$$

$$s_{\text{s}}[4] = \text{ENTROPY}(\text{Air}, T=T_{\text{s}}[4], P=P[4]) \text{ "T}_{\text{s}}[4] \text{ is the isentropic value of } T[4] \text{ at turbine exit"}$$

$$\text{Eta_t} = W_{\text{dot_turb}} / W_{\text{dot_turbisen}} \text{ "turbine adiabatic efficiency, } W_{\text{dot_turbisen}} > W_{\text{dot_turb}} \text{"}$$

"SSSF First Law for the isentropic turbine, assuming: adiabatic, $ke=pe=0$

$$E_{\text{dot_in}} - E_{\text{dot_out}} = \text{DELTA}E_{\text{dot_cv}} = 0 \text{ for steady-flow"}$$

$$m_{\dot{h}[3]} = W_{\dot{\text{turbisen}}} + m_{\dot{h}_s[4]}$$

$$h_s[4] = \text{ENTHALPY}(\text{Air}, T = T_s[4])$$

"Actual Turbine analysis:"

$$m_{\dot{h}[3]} = W_{\dot{\text{turb}}} + m_{\dot{h}[4]}$$

$$h[4] = \text{ENTHALPY}(\text{Air}, T = T[4])$$

$$s[4] = \text{ENTROPY}(\text{Air}, T = T[4], P = P[4])$$

"Cycle analysis"

"Using the definition of the net cycle work and 1 MW = 1000 kW:"

$$W_{\dot{\text{net}}*1000} = W_{\dot{\text{turb}}} - W_{\dot{\text{comp}}} \text{ "kJ/s"}$$

$$\text{Eta}_{\text{th_noreg}} = W_{\dot{\text{net}}*1000} / Q_{\dot{\text{in_noreg}}} \text{ "Cycle thermal efficiency"}$$

$$\text{Bwr} = W_{\dot{\text{comp}}} / W_{\dot{\text{turb}}} \text{ "Back work ratio"}$$

"With the regenerator the heat added in the external heat exchanger is"

$$m_{\dot{h}[5]} + Q_{\dot{\text{in_withreg}}} = m_{\dot{h}[3]}$$

$$q_{\text{in_withreg}} = Q_{\dot{\text{in_withreg}}} / m_{\dot{h}}$$

$$h[5] = \text{ENTHALPY}(\text{Air}, T = T[5])$$

$$s[5] = \text{ENTROPY}(\text{Air}, T = T[5], P = P[5])$$

$$P[5] = P[2]$$

"The regenerator effectiveness gives h[5] and thus T[5] as:"

$$\text{Eta}_{\text{reg}} = (h[5] - h[2]) / (h[4] - h[2])$$

"Energy balance on regenerator gives h[6] and thus T[6] as:"

$$m_{\dot{h}[2]} + m_{\dot{h}[4]} = m_{\dot{h}[5]} + m_{\dot{h}[6]}$$

$$h[6] = \text{ENTHALPY}(\text{Air}, T = T[6])$$

$$s[6] = \text{ENTROPY}(\text{Air}, T = T[6], P = P[6])$$

$$P[6] = P[4]$$

"Cycle thermal efficiency with regenerator"

$$\text{Eta}_{\text{th_withreg}} = W_{\dot{\text{net}}*1000} / Q_{\dot{\text{in_withreg}}}$$

"The following data is used to complete the Array Table for plotting purposes."

$$s_s[1] = s[1]$$

$$T_s[1] = T[1]$$

$$s_s[3] = s[3]$$

$$T_s[3] = T[3]$$

$$s_s[5] = \text{ENTROPY}(\text{Air}, T = T[5], P = P[5])$$

$$T_s[5] = T[5]$$

$$s_s[6] = s[6]$$

$$T_s[6] = T[6]$$

η_t	η_c	$\eta_{th,noreg}$	$\eta_{th,withreg}$	$Q_{innoreg}$ [kW]	$Q_{inwithreg}$ [kW]	W_{net} [kW]
0.7	0.892	0.2309	0.3405	442063	299766	102.1
0.75	0.892	0.2736	0.3841	442063	314863	120.9
0.8	0.892	0.3163	0.4237	442063	329960	139.8
0.85	0.892	0.359	0.4599	442063	345056	158.7
0.9	0.892	0.4016	0.493	442063	360153	177.6
0.95	0.892	0.4443	0.5234	442063	375250	196.4
1	0.892	0.487	0.5515	442063	390346	215.3

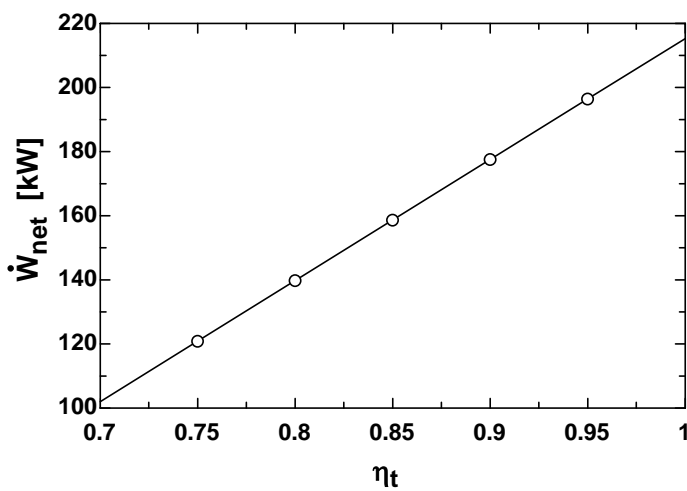
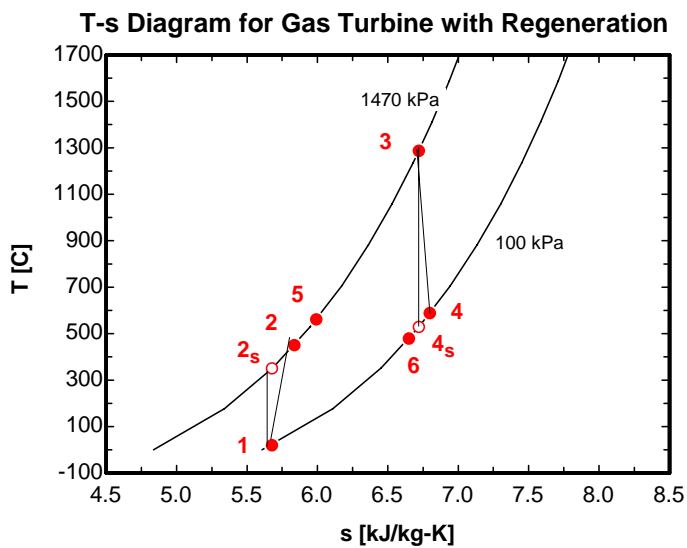

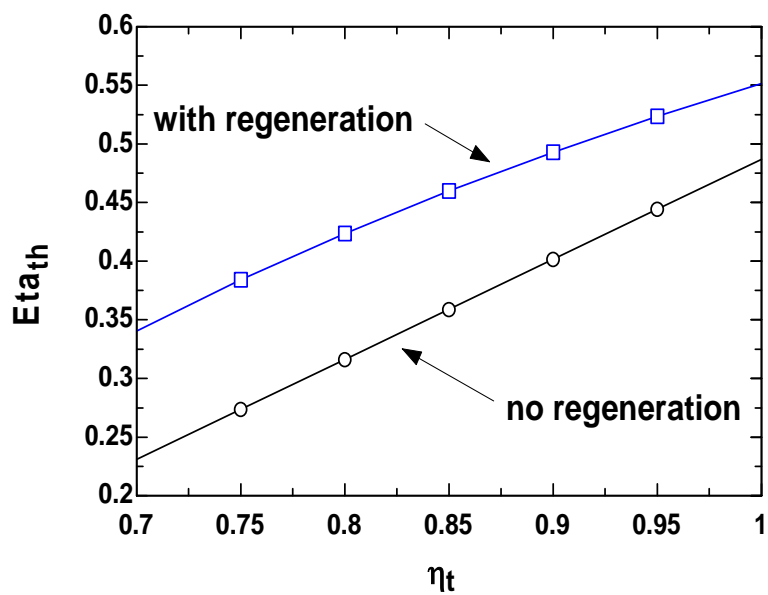
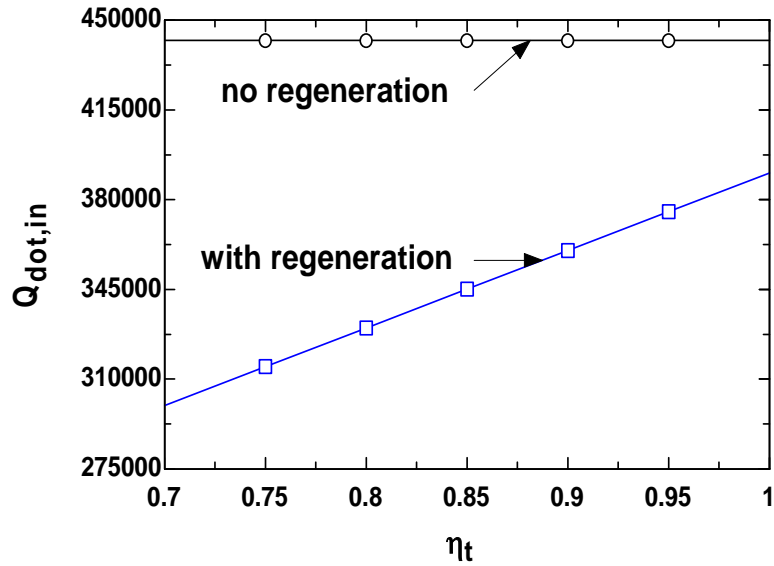

9-119 A Brayton cycle with regeneration using air as the working fluid is considered. The air temperature at the turbine exit, the net work output, and the thermal efficiency are to be determined.

Assumptions 1 The air standard assumptions are applicable. **2** Air is an ideal gas with variable specific heats. **3** Kinetic and potential energy changes are negligible.

Properties The properties of air are given in Table A-17.

Analysis (a) The properties of air at various states are

$$T_1 = 310 \text{ K} \longrightarrow h_1 = 310.24 \text{ kJ/kg}$$

$$P_{r_1} = 1.5546$$

$$P_{r_2} = \frac{P_2}{P_1} P_{r_1} = (7)(1.5546) = 10.88 \longrightarrow h_{2s} = 541.26 \text{ kJ/kg}$$

$$\eta_C = \frac{h_{2s} - h_1}{h_2 - h_1} \longrightarrow h_2 = h_1 + (h_{2s} - h_1)/\eta_C = 310.24 + (541.26 - 310.24)/(0.75) = 618.26 \text{ kJ/kg}$$

$$T_3 = 1150 \text{ K} \longrightarrow h_3 = 1219.25 \text{ kJ/kg}$$

$$P_{r_3} = 200.15$$

$$P_{r_4} = \frac{P_4}{P_3} P_{r_3} = \left(\frac{1}{7}\right)(200.15) = 28.59 \longrightarrow h_{4s} = 711.80 \text{ kJ/kg}$$

$$\eta_T = \frac{h_3 - h_4}{h_3 - h_{4s}} \longrightarrow h_4 = h_3 - \eta_T(h_3 - h_{4s}) = 1219.25 - (0.82)(1219.25 - 711.80) = 803.14 \text{ kJ/kg}$$

Thus,

$$T_4 = \mathbf{782.8 \text{ K}}$$

$$(b) \quad w_{\text{net}} = w_{T,\text{out}} - w_{C,\text{in}} = (h_3 - h_4) - (h_2 - h_1)$$

$$= (1219.25 - 803.14) - (618.26 - 310.24)$$

$$= \mathbf{108.09 \text{ kJ/kg}}$$

$$(c) \quad \varepsilon = \frac{h_5 - h_2}{h_4 - h_2} \longrightarrow h_5 = h_2 + \varepsilon(h_4 - h_2)$$

$$= 618.26 + (0.65)(803.14 - 618.26)$$

$$= 738.43 \text{ kJ/kg}$$

Then,

$$q_{\text{in}} = h_3 - h_5 = 1219.25 - 738.43 = 480.82 \text{ kJ/kg}$$

$$\eta_{\text{th}} = \frac{w_{\text{net}}}{q_{\text{in}}} = \frac{108.09 \text{ kJ/kg}}{480.82 \text{ kJ/kg}} = \mathbf{22.5\%}$$

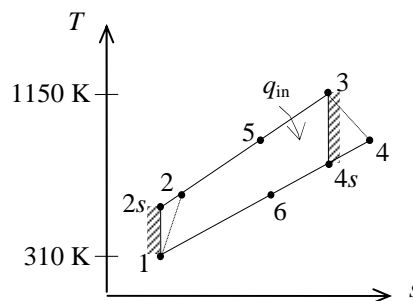

9-120 A stationary gas-turbine power plant operating on an ideal regenerative Brayton cycle with air as the working fluid is considered. The power delivered by this plant is to be determined for two cases.

Assumptions 1 The air standard assumptions are applicable. **2** Air is an ideal gas. **3** Kinetic and potential energy changes are negligible.

Properties When assuming constant specific heats, the properties of air at room temperature are $c_p = 1.005$ kJ/kg.K and $k = 1.4$ (Table A-2a). When assuming variable specific heats, the properties of air are obtained from Table A-17.

Analysis (a) Assuming constant specific heats,

$$T_2 = T_1 \left(\frac{P_2}{P_1} \right)^{(k-1)/k} = (290 \text{ K})(8)^{0.4/1.4} = 525.3 \text{ K}$$

$$T_4 = T_3 \left(\frac{P_4}{P_3} \right)^{(k-1)/k} = (1100 \text{ K}) \left(\frac{1}{8} \right)^{0.4/1.4} = 607.2 \text{ K}$$

$$\varepsilon = 100\% \longrightarrow T_5 = T_4 = 607.2 \text{ K and } T_6 = T_2 = 525.3 \text{ K}$$

$$\eta_{\text{th}} = 1 - \frac{q_{\text{out}}}{q_{\text{in}}} = 1 - \frac{c_p(T_6 - T_1)}{c_p(T_3 - T_5)} = 1 - \frac{T_6 - T_1}{T_3 - T_5} = 1 - \frac{525.3 - 290}{1100 - 607.2} = 0.5225$$

$$\dot{W}_{\text{net}} = \eta_T \dot{Q}_{\text{in}} = (0.5225)(75,000 \text{ kW}) = \mathbf{39,188 \text{ kW}}$$

(b) Assuming variable specific heats,

$$T_1 = 290 \text{ K} \longrightarrow \begin{aligned} h_1 &= 290.16 \text{ kJ/kg} \\ P_{r_1} &= 1.2311 \end{aligned}$$

$$P_{r_2} = \frac{P_2}{P_1} P_{r_1} = (8)(1.2311) = 9.8488 \longrightarrow h_2 = 526.12 \text{ kJ/kg}$$

$$T_3 = 1100 \text{ K} \longrightarrow \begin{aligned} h_3 &= 1161.07 \text{ kJ/kg} \\ P_{r_3} &= 167.1 \end{aligned}$$

$$P_{r_4} = \frac{P_4}{P_3} P_{r_3} = \left(\frac{1}{8} \right) (167.1) = 20.89 \longrightarrow h_4 = 651.37 \text{ kJ/kg}$$

$$\varepsilon = 100\% \longrightarrow h_5 = h_4 = 651.37 \text{ kJ/kg and } h_6 = h_2 = 526.12 \text{ kJ/kg}$$

$$\eta_{\text{th}} = 1 - \frac{q_{\text{out}}}{q_{\text{in}}} = 1 - \frac{h_6 - h_1}{h_3 - h_5} = 1 - \frac{526.12 - 290.16}{1161.07 - 651.37} = 0.5371$$

$$\dot{W}_{\text{net}} = \eta_T \dot{Q}_{\text{in}} = (0.5371)(75,000 \text{ kW}) = \mathbf{40,283 \text{ kW}}$$

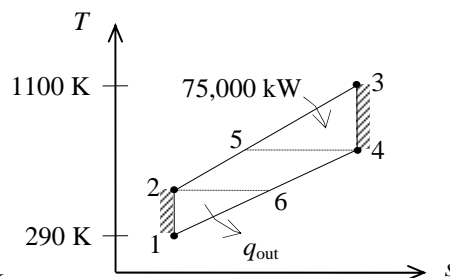

9-121 A regenerative gas-turbine engine using air as the working fluid is considered. The amount of heat transfer in the regenerator and the thermal efficiency are to be determined.

Assumptions 1 The air standard assumptions are applicable. **2** Air is an ideal gas with variable specific heats. **3** Kinetic and potential energy changes are negligible.

Properties The properties of air are given in Table A-17.

Analysis (a) The properties at various states are

$$r_p = P_2 / P_1 = 800 / 100 = 8$$

$$T_1 = 300 \text{ K} \longrightarrow h_1 = 300.19 \text{ kJ/kg}$$

$$T_2 = 580 \text{ K} \longrightarrow h_2 = 586.04 \text{ kJ/kg}$$

$$T_3 = 1200 \text{ K} \longrightarrow h_3 = 1277.79 \text{ kJ/kg}$$

$$P_{r_3} = 238.0$$

$$P_{r_4} = \frac{P_4}{P_3} P_{r_3} = \left(\frac{1}{8}\right)(238.0) = 29.75 \longrightarrow h_{4s} = 719.75 \text{ kJ/kg}$$

$$\eta_T = \frac{h_3 - h_4}{h_3 - h_{4s}} \longrightarrow h_4 = h_3 - \eta_T (h_3 - h_{4s})$$

$$= 1277.79 - (0.86)(1277.79 - 719.75)$$

$$= 797.88 \text{ kJ/kg}$$

$$q_{\text{regen}} = \varepsilon (h_4 - h_2) = (0.72)(797.88 - 586.04) = \mathbf{152.5 \text{ kJ/kg}}$$

$$(b) \quad w_{\text{net}} = w_{T,\text{out}} - w_{C,\text{in}} = (h_3 - h_4) - (h_2 - h_1)$$

$$= (1277.79 - 797.88) - (586.04 - 300.19) = 194.06 \text{ kJ/kg}$$

$$q_{\text{in}} = (h_3 - h_2) - q_{\text{regen}} = (1277.79 - 586.04) - 152.52 = 539.23 \text{ kJ/kg}$$

$$\eta_{\text{th}} = \frac{w_{\text{net}}}{q_{\text{in}}} = \frac{194.06 \text{ kJ/kg}}{539.23 \text{ kJ/kg}} = \mathbf{36.0\%}$$

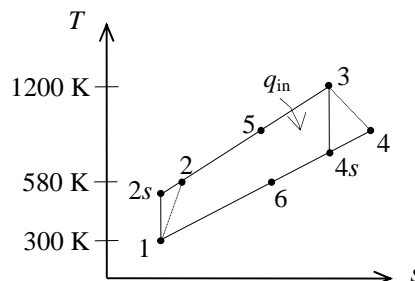

9-122 A regenerative gas-turbine engine using air as the working fluid is considered. The amount of heat transfer in the regenerator and the thermal efficiency are to be determined.

Assumptions 1 The air standard assumptions are applicable. **2** Air is an ideal gas with constant specific heats. **3** Kinetic and potential energy changes are negligible.

Properties The properties of air at room temperature are $c_p = 1.005 \text{ kJ/kg}\cdot\text{K}$ and $k = 1.4$ (Table A-2a).

Analysis (a) Using the isentropic relations and turbine efficiency,

$$r_p = P_2 / P_1 = 800 / 100 = 8$$

$$T_{4s} = T_3 \left(\frac{P_4}{P_3} \right)^{(k-1)/k} = (1200 \text{ K}) \left(\frac{1}{8} \right)^{0.4/1.4} = 662.5 \text{ K}$$

$$\eta_T = \frac{h_3 - h_4}{h_3 - h_{4s}} = \frac{c_p(T_3 - T_4)}{c_p(T_3 - T_{4s})} \longrightarrow T_4 = T_3 - \eta_T(T_3 - T_{4s})$$

$$= 1200 - (0.86)(1200 - 662.5)$$

$$= 737.8 \text{ K}$$

$$q_{\text{regen}} = \varepsilon(h_4 - h_2) = \varepsilon c_p(T_4 - T_2) = (0.72)(1.005 \text{ kJ/kg}\cdot\text{K})(737.8 - 580) \text{ K} = \mathbf{114.2 \text{ kJ/kg}}$$

$$(b) \quad w_{\text{net}} = w_{T,\text{out}} - w_{C,\text{in}} = c_p(T_3 - T_4) - c_p(T_2 - T_1)$$

$$= (1.005 \text{ kJ/kg}\cdot\text{K})[(1200 - 737.8) - (580 - 300)] \text{ K} = 183.1 \text{ kJ/kg}$$

$$q_{\text{in}} = (h_3 - h_2) - q_{\text{regen}} = c_p(T_3 - T_2) - q_{\text{regen}}$$

$$= (1.005 \text{ kJ/kg}\cdot\text{K})(1200 - 580) \text{ K} - 114.2 = 508.9 \text{ kJ/kg}$$

$$\eta_{\text{th}} = \frac{w_{\text{net}}}{q_{\text{in}}} = \frac{183.1 \text{ kJ/kg}}{508.9 \text{ kJ/kg}} = \mathbf{36.0\%}$$

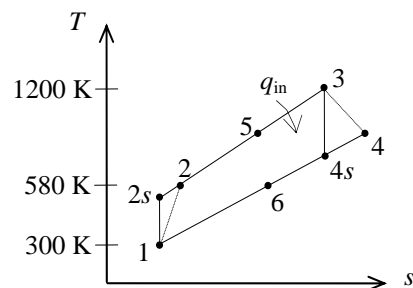

9-123 A regenerative gas-turbine engine using air as the working fluid is considered. The amount of heat transfer in the regenerator and the thermal efficiency are to be determined.

Assumptions 1 The air standard assumptions are applicable. **2** Air is an ideal gas with variable specific heats. **3** Kinetic and potential energy changes are negligible.

Properties The properties of air are given in Table A-17.

Analysis (a) The properties of air at various states are

$$r_p = P_2 / P_1 = 800 / 100 = 8$$

$$T_1 = 300\text{K} \longrightarrow h_1 = 300.19\text{kJ/kg}$$

$$T_2 = 580\text{K} \longrightarrow h_2 = 586.04\text{kJ/kg}$$

$$T_3 = 1200\text{K} \longrightarrow h_3 = 1277.79\text{kJ/kg}$$

$$P_{r_3} = 238.0$$

$$P_{r_4} = \frac{P_4}{P_3} P_{r_3} = \left(\frac{1}{8}\right)(238.0) = 29.75 \longrightarrow h_{4s} = 719.75\text{kJ/kg}$$

$$\eta_T = \frac{h_3 - h_4}{h_3 - h_{4s}} \longrightarrow h_4 = h_3 - \eta_T(h_3 - h_{4s}) = 1277.79 - (0.86)(1277.79 - 719.75) = 797.88\text{kJ/kg}$$

$$q_{\text{regen}} = \varepsilon(h_3 - h_2) = (0.70)(1277.79 - 586.04) = \mathbf{148.3\text{kJ/kg}}$$

$$(b) \quad w_{\text{net}} = w_{T,\text{out}} - w_{C,\text{in}} = (h_3 - h_4) - (h_2 - h_1) = (1277.79 - 797.88) - (586.04 - 300.19) = 194.06\text{kJ/kg}$$

$$q_{\text{in}} = (h_3 - h_2) - q_{\text{regen}} = (1277.79 - 586.04) - 148.3 = 543.5\text{kJ/kg}$$

$$\eta_{\text{th}} = \frac{w_{\text{net}}}{q_{\text{in}}} = \frac{194.06\text{kJ/kg}}{543.5\text{kJ/kg}} = \mathbf{35.7\%}$$

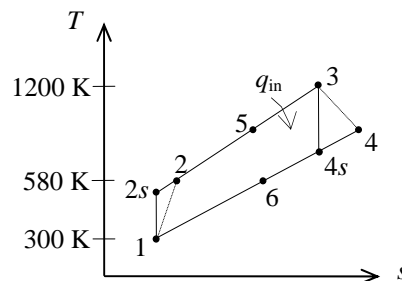

Brayton Cycle with Intercooling, Reheating, and Regeneration

9-124C As the number of compression and expansion stages are increased and regeneration is employed, the ideal Brayton cycle will approach the Ericsson cycle.

9-125C (a) decrease, (b) decrease, and (c) decrease.

9-126C (a) increase, (b) decrease, and (c) decrease.

9-127C (a) increase, (b) decrease, (c) decrease, and (d) increase.

9-128C (a) increase, (b) decrease, (c) increase, and (d) decrease.

9-129C Because the steady-flow work is proportional to the specific volume of the gas. Intercooling decreases the average specific volume of the gas during compression, and thus the compressor work. Reheating increases the average specific volume of the gas, and thus the turbine work output.

9-130C (c) The Carnot (or Ericsson) cycle efficiency.

9-131 An ideal gas-turbine cycle with two stages of compression and two stages of expansion is considered. The back work ratio and the thermal efficiency of the cycle are to be determined for the cases of with and without a regenerator.

Assumptions 1 The air standard assumptions are applicable. **2** Air is an ideal gas with variable specific heats. **3** Kinetic and potential energy changes are negligible.

Properties The properties of air are given in Table A-17.

Analysis (a) The work inputs to each stage of compressor are identical, so are the work outputs of each stage of the turbine since this is an ideal cycle. Then,

$$T_1 = 300 \text{ K} \longrightarrow \begin{matrix} h_1 = 300.19 \text{ kJ/kg} \\ P_{r_1} = 1.386 \end{matrix}$$

$$P_{r_2} = \frac{P_2}{P_1} P_{r_1} = (3)(1.386) = 4.158 \longrightarrow h_2 = h_4 = 411.26 \text{ kJ/kg}$$

$$T_5 = 1200 \text{ K} \longrightarrow \begin{matrix} h_5 = h_7 = 1277.79 \text{ kJ/kg} \\ P_{r_5} = 238 \end{matrix}$$

$$P_{r_6} = \frac{P_6}{P_5} P_{r_5} = \left(\frac{1}{3}\right)(238) = 79.33 \longrightarrow h_6 = h_8 = 946.36 \text{ kJ/kg}$$

$$w_{C,\text{in}} = 2(h_2 - h_1) = 2(411.26 - 300.19) = 222.14 \text{ kJ/kg}$$

$$w_{T,\text{out}} = 2(h_5 - h_6) = 2(1277.79 - 946.36) = 662.86 \text{ kJ/kg}$$

Thus,

$$r_{\text{bw}} = \frac{w_{C,\text{in}}}{w_{T,\text{out}}} = \frac{222.14 \text{ kJ/kg}}{662.86 \text{ kJ/kg}} = \mathbf{33.5\%}$$

$$q_{\text{in}} = (h_5 - h_4) + (h_7 - h_6) = (1277.79 - 411.26) + (1277.79 - 946.36) = 1197.96 \text{ kJ/kg}$$

$$w_{\text{net}} = w_{T,\text{out}} - w_{C,\text{in}} = 662.86 - 222.14 = 440.72 \text{ kJ/kg}$$

$$\eta_{\text{th}} = \frac{w_{\text{net}}}{q_{\text{in}}} = \frac{440.72 \text{ kJ/kg}}{1197.96 \text{ kJ/kg}} = \mathbf{36.8\%}$$

(b) When a regenerator is used, r_{bw} remains the same. The thermal efficiency in this case becomes

$$q_{\text{regen}} = \varepsilon(h_8 - h_4) = (0.75)(946.36 - 411.26) = 401.33 \text{ kJ/kg}$$

$$q_{\text{in}} = q_{\text{in,old}} - q_{\text{regen}} = 1197.96 - 401.33 = 796.63 \text{ kJ/kg}$$

$$\eta_{\text{th}} = \frac{w_{\text{net}}}{q_{\text{in}}} = \frac{440.72 \text{ kJ/kg}}{796.63 \text{ kJ/kg}} = \mathbf{55.3\%}$$

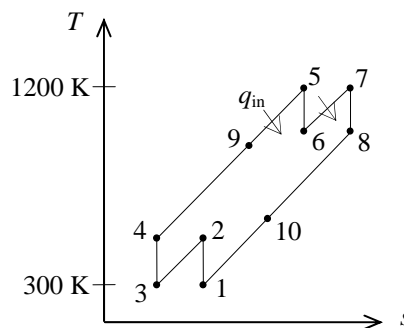

9-132 A gas-turbine cycle with two stages of compression and two stages of expansion is considered. The back work ratio and the thermal efficiency of the cycle are to be determined for the cases of with and without a regenerator.

Assumptions 1 The air standard assumptions are applicable. 2 Air is an ideal gas with variable specific heats. 3 Kinetic and potential energy changes are negligible.

Properties The properties of air are given in Table A-17.

Analysis (a) The work inputs to each stage of compressor are identical, so are the work outputs of each stage of the turbine. Then,

$$T_1 = 300 \text{ K} \longrightarrow h_1 = 300.19 \text{ kJ/kg}$$

$$P_{r_1} = 1.386$$

$$P_{r_2} = \frac{P_2}{P_1} P_{r_1} = (3)(1.386) = 4.158 \longrightarrow h_{2s} = h_{4s} = 411.26 \text{ kJ/kg}$$

$$\eta_C = \frac{h_{2s} - h_1}{h_2 - h_1} \longrightarrow h_2 = h_4 = h_1 + (h_{2s} - h_1) / \eta_C$$

$$= 300.19 + (411.26 - 300.19) / (0.80)$$

$$= 439.03 \text{ kJ/kg}$$

$$T_5 = 1200 \text{ K} \longrightarrow h_5 = h_7 = 1277.79 \text{ kJ/kg}$$

$$P_{r_5} = 238$$

$$P_{r_6} = \frac{P_6}{P_5} P_{r_5} = \left(\frac{1}{3}\right)(238) = 79.33 \longrightarrow h_6 = h_8 = 946.36 \text{ kJ/kg}$$

$$\eta_T = \frac{h_5 - h_6}{h_5 - h_{6s}} \longrightarrow h_6 = h_8 = h_5 - \eta_T (h_5 - h_{6s})$$

$$= 1277.79 - (0.85)(1277.79 - 946.36)$$

$$= 996.07 \text{ kJ/kg}$$

$$w_{C,\text{in}} = 2(h_2 - h_1) = 2(439.03 - 300.19) = 277.68 \text{ kJ/kg}$$

$$w_{T,\text{out}} = 2(h_5 - h_6) = 2(1277.79 - 996.07) = 563.44 \text{ kJ/kg}$$

Thus,

$$r_{\text{bw}} = \frac{w_{C,\text{in}}}{w_{T,\text{out}}} = \frac{277.68 \text{ kJ/kg}}{563.44 \text{ kJ/kg}} = \mathbf{49.3\%}$$

$$q_{\text{in}} = (h_5 - h_4) + (h_7 - h_6) = (1277.79 - 439.03) + (1277.79 - 996.07) = 1120.48 \text{ kJ/kg}$$

$$w_{\text{net}} = w_{T,\text{out}} - w_{C,\text{in}} = 563.44 - 277.68 = 285.76 \text{ kJ/kg}$$

$$\eta_{\text{th}} = \frac{w_{\text{net}}}{q_{\text{in}}} = \frac{285.76 \text{ kJ/kg}}{1120.48 \text{ kJ/kg}} = \mathbf{25.5\%}$$

(b) When a regenerator is used, r_{bw} remains the same. The thermal efficiency in this case becomes

$$q_{\text{regen}} = \varepsilon(h_8 - h_4) = (0.75)(996.07 - 439.03) = 417.78 \text{ kJ/kg}$$

$$q_{\text{in}} = q_{\text{in,old}} - q_{\text{regen}} = 1120.48 - 417.78 = 702.70 \text{ kJ/kg}$$

$$\eta_{\text{th}} = \frac{w_{\text{net}}}{q_{\text{in}}} = \frac{285.76 \text{ kJ/kg}}{702.70 \text{ kJ/kg}} = \mathbf{40.7\%}$$

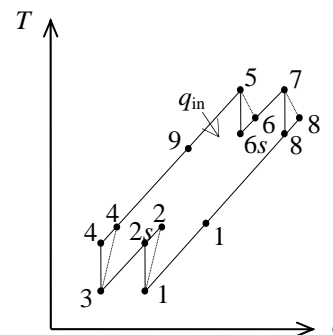

9-133E A regenerative gas-turbine cycle with two stages of compression and two stages of expansion is considered. The mass flow rate of air and the rates of heat addition and rejection for a specified net power output are to be determined.

Assumptions 1 The air standard assumptions are applicable. **2** Air is an ideal gas with constant specific heats at room temperature. **3** Kinetic and potential energy changes are negligible.

Properties The properties of air at room temperature are $c_p = 0.24$ Btu/lbm·R and $k = 1.4$ (Table A-2Ea).

Analysis According to the isentropic process expressions for an ideal gas,

$$T_2 = T_4 = T_1 r_p^{(k-1)/k} = (520 \text{ R})(3)^{0.4/1.4} = 711.7 \text{ R}$$

$$T_7 = T_9 = T_6 \left(\frac{1}{r_p} \right)^{(k-1)/k} = (1400 \text{ R}) \left(\frac{1}{3} \right)^{0.4/1.4} = 1023 \text{ R}$$

The regenerator is ideal (i.e., the effectiveness is 100%) and thus,

$$T_5 = T_7 = 1023 \text{ R}$$

$$T_{10} = T_2 = 711.7 \text{ R}$$

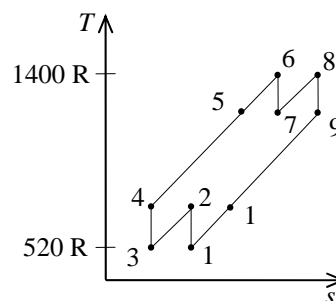

The net work output is determined as follows

$$w_{C,in} = 2c_p (T_2 - T_1) = 2(0.24 \text{ Btu/lbm} \cdot \text{R})(711.7 - 520) \text{ R} = 92.02 \text{ Btu/lbm}$$

$$w_{T,out} = 2c_p (T_6 - T_7) = 2(0.24 \text{ Btu/lbm} \cdot \text{R})(1400 - 1023) \text{ R} = 180.96 \text{ Btu/lbm}$$

$$w_{net} = w_{T,out} - w_{C,in} = 180.96 - 92.02 = 88.94 \text{ Btu/lbm}$$

The mass flow rate is then

$$\dot{m} = \frac{\dot{W}_{net}}{w_{net}} = \frac{1000 \text{ hp}}{88.94 \text{ Btu/lbm}} \left(\frac{0.7068 \text{ Btu/s}}{1 \text{ hp}} \right) = \mathbf{7.947 \text{ lbm/s}}$$

Applying the first law to the heat addition processes gives

$$\begin{aligned} \dot{Q}_{in} &= \dot{m}c_p (T_6 - T_5) + \dot{m}c_p (T_8 - T_7) \\ &= (7.947 \text{ lbm/s})(0.24 \text{ Btu/lbm} \cdot \text{R})(1400 - 1023 + 1400 - 1023) \text{ R} \\ &= \mathbf{1438 \text{ Btu/s}} \end{aligned}$$

Similarly,

$$\begin{aligned} \dot{Q}_{out} &= \dot{m}c_p (T_{10} - T_1) + \dot{m}c_p (T_2 - T_3) \\ &= (7.947 \text{ lbm/s})(0.24 \text{ Btu/lbm} \cdot \text{R})(711.7 - 520 + 711.7 - 520) \text{ R} \\ &= \mathbf{731 \text{ Btu/s}} \end{aligned}$$

9-134E A regenerative gas-turbine cycle with two stages of compression and two stages of expansion is considered. The mass flow rate of air and the rates of heat addition and rejection for a specified net power output are to be determined.

Assumptions 1 The air standard assumptions are applicable. **2** Air is an ideal gas with constant specific heats at room temperature. **3** Kinetic and potential energy changes are negligible.

Properties The properties of air at room temperature are $c_p = 0.24$ Btu/lbm·R and $k = 1.4$ (Table A-2Ea).

Analysis For the compression and expansion processes, we have

$$T_{2s} = T_{4s} = T_1 r_p^{(k-1)/k} = (520 \text{ R})(3)^{0.4/1.4} = 711.7 \text{ R}$$

$$\eta_C = \frac{c_p (T_{2s} - T_1)}{c_p (T_2 - T_1)} \longrightarrow T_2 = T_4 = T_1 + \frac{T_{2s} - T_1}{\eta_C}$$

$$= 520 + \frac{711.7 - 520}{0.88} = 737.8 \text{ R}$$

$$T_{7s} = T_{9s} = T_6 \left(\frac{1}{r_p} \right)^{(k-1)/k} = (1400 \text{ R}) \left(\frac{1}{3} \right)^{0.4/1.4} = 1023 \text{ R}$$

$$\eta_T = \frac{c_p (T_6 - T_7)}{c_p (T_6 - T_{7s})} \longrightarrow T_7 = T_9 = T_6 - \eta_T (T_6 - T_{7s})$$

$$= 1400 - (0.93)(1400 - 1023) = 1049 \text{ R}$$

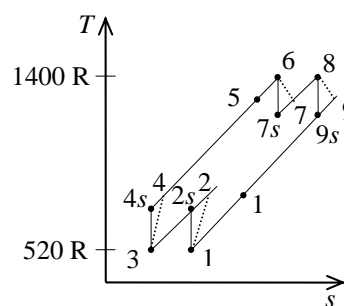

The regenerator is ideal (i.e., the effectiveness is 100%) and thus,

$$T_5 = T_7 = 1049 \text{ R}$$

$$T_{10} = T_2 = 737.8 \text{ R}$$

The net work output is determined as follows

$$w_{C,in} = 2c_p (T_2 - T_1) = 2(0.24 \text{ Btu/lbm} \cdot \text{R})(737.8 - 520) \text{ R} = 104.54 \text{ Btu/lbm}$$

$$w_{T,out} = 2c_p (T_6 - T_7) = 2(0.24 \text{ Btu/lbm} \cdot \text{R})(1400 - 1049) \text{ R} = 168.48 \text{ Btu/lbm}$$

$$w_{net} = w_{T,out} - w_{C,in} = 168.48 - 104.54 = 63.94 \text{ Btu/lbm}$$

The mass flow rate is then

$$\dot{m} = \frac{\dot{W}_{net}}{w_{net}} = \frac{1000 \text{ hp}}{63.94 \text{ Btu/lbm}} \left(\frac{0.7068 \text{ Btu/s}}{1 \text{ hp}} \right) = 11.05 \text{ lbm/s}$$

The rate of heat addition is then

$$\dot{Q}_{in} = \dot{m} c_p (T_6 - T_5) + \dot{m} c_p (T_8 - T_7)$$

$$= (11.05 \text{ lbm/s})(0.24 \text{ Btu/lbm} \cdot \text{R})(1400 - 1049 + 1400 - 1049) \text{ R}$$

$$= \mathbf{1862 \text{ Btu/s}}$$

9-135 A regenerative gas-turbine cycle with two stages of compression and two stages of expansion is considered. The thermal efficiency of the cycle is to be determined.

Assumptions 1 The air standard assumptions are applicable. **2** Air is an ideal gas with constant specific heats at room temperature. **3** Kinetic and potential energy changes are negligible.

Properties The properties of air at room temperature are $c_p = 1.005 \text{ kJ/kg}\cdot\text{K}$ and $k = 1.4$ (Table A-2a).

Analysis The temperatures at various states are obtained as follows

$$T_2 = T_4 = T_1 r_p^{(k-1)/k} = (290 \text{ K})(4)^{0.4/1.4} = 430.9 \text{ K}$$

$$T_5 = T_4 + 20 = 430.9 + 20 = 450.9 \text{ K}$$

$$q_{\text{in}} = c_p (T_6 - T_5)$$

$$T_6 = T_5 + \frac{q_{\text{in}}}{c_p} = 450.9 \text{ K} + \frac{300 \text{ kJ/kg}}{1.005 \text{ kJ/kg}\cdot\text{K}} = 749.4 \text{ K}$$

$$T_7 = T_6 \left(\frac{1}{r_p} \right)^{(k-1)/k} = (749.4 \text{ K}) \left(\frac{1}{4} \right)^{0.4/1.4} = 504.3 \text{ K}$$

$$T_8 = T_7 + \frac{q_{\text{in}}}{c_p} = 504.3 \text{ K} + \frac{300 \text{ kJ/kg}}{1.005 \text{ kJ/kg}\cdot\text{K}} = 802.8 \text{ K}$$

$$T_9 = T_8 \left(\frac{1}{r_p} \right)^{(k-1)/k} = (802.8 \text{ K}) \left(\frac{1}{4} \right)^{0.4/1.4} = 540.2 \text{ K}$$

$$T_{10} = T_9 - 20 = 540.2 - 20 = 520.2 \text{ K}$$

The heat input is

$$q_{\text{in}} = 300 + 300 = 600 \text{ kJ/kg}$$

The heat rejected is

$$\begin{aligned} q_{\text{out}} &= c_p (T_{10} - T_1) + c_p (T_2 - T_3) \\ &= (1.005 \text{ kJ/kg}\cdot\text{K})(520.2 - 290 + 430.9 - 290) \text{ R} \\ &= 373.0 \text{ kJ/kg} \end{aligned}$$

The thermal efficiency of the cycle is then

$$\eta_{\text{th}} = 1 - \frac{q_{\text{out}}}{q_{\text{in}}} = 1 - \frac{373.0}{600} = \mathbf{0.378}$$

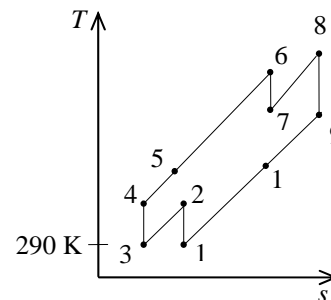

9-136 A regenerative gas-turbine cycle with three stages of compression and three stages of expansion is considered. The thermal efficiency of the cycle is to be determined.

Assumptions 1 The air standard assumptions are applicable. **2** Air is an ideal gas with constant specific heats at room temperature. **3** Kinetic and potential energy changes are negligible.

Properties The properties of air at room temperature are $c_p = 1.005 \text{ kJ/kg}\cdot\text{K}$ and $k = 1.4$ (Table A-2a).

Analysis The temperatures at various states are obtained as follows

$$T_2 = T_4 = T_6 = T_1 r_p^{(k-1)/k} = (290 \text{ K})(4)^{0.4/1.4} = 430.9 \text{ K}$$

$$T_7 = T_6 + 20 = 430.9 + 20 = 450.9 \text{ K}$$

$$q_{\text{in}} = c_p (T_8 - T_7)$$

$$T_8 = T_7 + \frac{q_{\text{in}}}{c_p} = 450.9 \text{ K} + \frac{300 \text{ kJ/kg}}{1.005 \text{ kJ/kg}\cdot\text{K}} = 749.4 \text{ K}$$

$$T_9 = T_8 \left(\frac{1}{r_p} \right)^{(k-1)/k} = (749.4 \text{ K}) \left(\frac{1}{4} \right)^{0.4/1.4} = 504.3 \text{ K}$$

$$T_{10} = T_9 + \frac{q_{\text{in}}}{c_p} = 504.3 \text{ K} + \frac{300 \text{ kJ/kg}}{1.005 \text{ kJ/kg}\cdot\text{K}} = 802.8 \text{ K}$$

$$T_{11} = T_{10} \left(\frac{1}{r_p} \right)^{(k-1)/k} = (802.8 \text{ K}) \left(\frac{1}{4} \right)^{0.4/1.4} = 540.2 \text{ K}$$

$$T_{12} = T_{11} + \frac{q_{\text{in}}}{c_p} = 540.2 \text{ K} + \frac{300 \text{ kJ/kg}}{1.005 \text{ kJ/kg}\cdot\text{K}} = 838.7 \text{ K}$$

$$T_{13} = T_{12} \left(\frac{1}{r_p} \right)^{(k-1)/k} = (838.7 \text{ K}) \left(\frac{1}{4} \right)^{0.4/1.4} = 564.4 \text{ K}$$

$$T_{14} = T_{13} - 20 = 564.4 - 20 = 544.4 \text{ K}$$

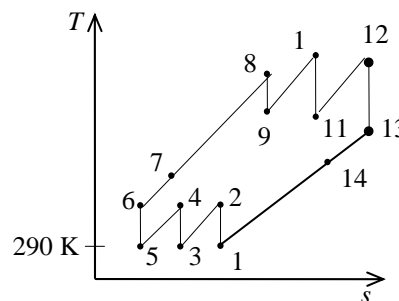

The heat input is

$$q_{\text{in}} = 300 + 300 + 300 = 900 \text{ kJ/kg}$$

The heat rejected is

$$\begin{aligned} q_{\text{out}} &= c_p (T_{14} - T_1) + c_p (T_2 - T_3) + c_p (T_4 - T_5) \\ &= (1.005 \text{ kJ/kg}\cdot\text{K})(544.4 - 290 + 430.9 - 290 + 430.9 - 290) \text{ K} \\ &= 538.9 \text{ kJ/kg} \end{aligned}$$

The thermal efficiency of the cycle is then

$$\eta_{\text{th}} = 1 - \frac{q_{\text{out}}}{q_{\text{in}}} = 1 - \frac{538.9}{900} = \mathbf{0.401}$$

9-137 A regenerative gas-turbine cycle with three stages of compression and three stages of expansion is considered. The thermal efficiency of the cycle is to be determined.

Assumptions 1 The air standard assumptions are applicable. **2** Air is an ideal gas with constant specific heats at room temperature. **3** Kinetic and potential energy changes are negligible.

Properties The properties of air at room temperature are $c_p = 1.005 \text{ kJ/kg}\cdot\text{K}$ and $k = 1.4$ (Table A-2a).

Analysis Since all compressors share the same compression ratio and begin at the same temperature,

$$T_2 = T_4 = T_6 = T_1 r_p^{(k-1)/k} = (290 \text{ K})(4)^{0.4/1.4} = 430.9 \text{ K}$$

From the problem statement,

$$T_7 = T_{13} - 40$$

The relations for heat input and expansion processes are

$$q_{\text{in}} = c_p (T_8 - T_7) \longrightarrow T_8 = T_7 + \frac{q_{\text{in}}}{c_p}$$

$$T_9 = T_8 \left(\frac{1}{r_p} \right)^{(k-1)/k}$$

$$T_{10} = T_9 + \frac{q_{\text{in}}}{c_p}, \quad T_{11} = T_{10} \left(\frac{1}{r_p} \right)^{(k-1)/k}$$

$$T_{12} = T_{11} + \frac{q_{\text{in}}}{c_p}, \quad T_{13} = T_{12} \left(\frac{1}{r_p} \right)^{(k-1)/k}$$

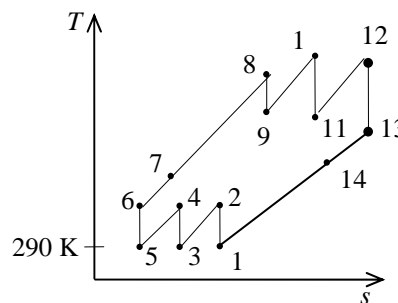

The simultaneous solution of above equations using EES software gives the following results

$$T_7 = 556.7 \text{ K}, \quad T_8 = 855.2 \text{ K}, \quad T_9 = 575.5 \text{ K}$$

$$T_{10} = 874.0 \text{ K}, \quad T_{11} = 588.2 \text{ K}, \quad T_{12} = 886.7 \text{ K}, \quad T_{13} = 596.7 \text{ K}$$

From an energy balance on the regenerator,

$$T_7 - T_6 = T_{13} - T_{14}$$

$$(T_{13} - 40) - T_6 = T_{13} - T_{14} \longrightarrow T_{14} = T_6 + 40 = 430.9 + 40 = 470.9 \text{ K}$$

The heat input is

$$q_{\text{in}} = 300 + 300 + 300 = 900 \text{ kJ/kg}$$

The heat rejected is

$$\begin{aligned} q_{\text{out}} &= c_p (T_{14} - T_1) + c_p (T_2 - T_3) + c_p (T_4 - T_5) \\ &= (1.005 \text{ kJ/kg}\cdot\text{K})(470.9 - 290 + 430.9 - 290 + 430.9 - 290) \text{ R} \\ &= 465.0 \text{ kJ/kg} \end{aligned}$$

The thermal efficiency of the cycle is then

$$\eta_{\text{th}} = 1 - \frac{q_{\text{out}}}{q_{\text{in}}} = 1 - \frac{465.0}{900} = \mathbf{0.483}$$

Jet-Propulsion Cycles

9-138C The power developed from the thrust of the engine is called the propulsive power. It is equal to thrust times the aircraft velocity.

9-139C The ratio of the propulsive power developed and the rate of heat input is called the propulsive efficiency. It is determined by calculating these two quantities separately, and taking their ratio.

9-140C It reduces the exit velocity, and thus the thrust.

9-141E A turboprop engine operating on an ideal cycle is considered. The thrust force generated is to be determined.

Assumptions 1 Steady operating conditions exist. 2 The air standard assumptions are applicable. 3 Air is an ideal gas with constant specific heats at room temperature. 4 The turbine work output is equal to the compressor work input.

Properties The properties of air at room temperature are $R = 0.3704 \text{ psia}\cdot\text{ft}^3/\text{lbm}\cdot\text{R}$ (Table A-1E), $c_p = 0.24 \text{ Btu}/\text{lbm}\cdot\text{R}$ and $k = 1.4$ (Table A-2Ea).

Analysis Working across the two isentropic processes of the cycle yields

$$T_2 = T_1 r_p^{(k-1)/k} = (450 \text{ R})(10)^{0.4/1.4} = 868.8 \text{ R}$$

$$T_5 = T_3 \left(\frac{1}{r_p} \right)^{(k-1)/k} = (1400 \text{ R}) \left(\frac{1}{10} \right)^{0.4/1.4} = 725.1 \text{ R}$$

Since the work produced by expansion 3-4 equals that used by compression 1-2, an energy balance gives

$$T_4 = T_3 - (T_2 - T_1) = 1400 - (868.8 - 450) = 981.2 \text{ R}$$

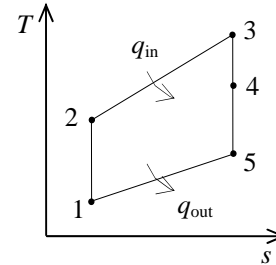

The excess enthalpy generated by expansion 4-5 is used to increase the kinetic energy of the flow through the propeller,

$$\dot{m}_e c_p (T_4 - T_5) = \dot{m}_p \frac{V_{\text{exit}}^2 - V_{\text{inlet}}^2}{2}$$

which when solved for the velocity at which the air leaves the propeller gives

$$\begin{aligned} V_{\text{exit}} &= \left[2 \frac{\dot{m}_e}{\dot{m}_p} c_p (T_4 - T_5) + V_{\text{inlet}}^2 \right]^{1/2} \\ &= \left[2 \frac{1}{20} (0.24 \text{ Btu}/\text{lbm}\cdot\text{R})(981.2 - 725.1) \text{R} \left(\frac{25,037 \text{ ft}^2/\text{s}^2}{1 \text{ Btu}/\text{lbm}} \right) + (600 \text{ ft/s})^2 \right]^{1/2} \\ &= 716.9 \text{ ft/s} \end{aligned}$$

The mass flow rate through the propeller is

$$\begin{aligned} \nu_1 &= \frac{RT}{P} = \frac{(0.3704 \text{ psia}\cdot\text{ft}^3)(450 \text{ R})}{8 \text{ psia}} = 20.84 \text{ ft}^3/\text{lbm} \\ \dot{m}_p &= \frac{AV_1}{\nu_1} = \frac{\pi D^2}{4} \frac{V_1}{\nu_1} = \frac{\pi (10 \text{ ft})^2}{4} \frac{600 \text{ ft/s}}{20.84 \text{ ft}^3/\text{lbm}} = 2261 \text{ lbm/s} \end{aligned}$$

The thrust force generated by this propeller is then

$$F = \dot{m}_p (V_{\text{exit}} - V_{\text{inlet}}) = (2261 \text{ lbm/s})(716.9 - 600) \text{ ft/s} \left(\frac{1 \text{ lbf}}{32.174 \text{ lbm}\cdot\text{ft/s}^2} \right) = \mathbf{8215 \text{ lbf}}$$

9-142E A turboprop engine operating on an ideal cycle is considered. The thrust force generated is to be determined.

Assumptions 1 Steady operating conditions exist. 2 The air standard assumptions are applicable. 3 Air is an ideal gas with constant specific heats at room temperature. 4 The turbine work output is equal to the compressor work input.

Properties The properties of air at room temperature are $R = 0.3704 \text{ psia}\cdot\text{ft}^3/\text{lbm}\cdot\text{R}$ (Table A-1E), $c_p = 0.24 \text{ Btu}/\text{lbm}\cdot\text{R}$ and $k = 1.4$ (Table A-2Ea).

Analysis Working across the two isentropic processes of the cycle yields

$$T_2 = T_1 r_p^{(k-1)/k} = (450 \text{ R})(10)^{0.4/1.4} = 868.8 \text{ R}$$

$$T_5 = T_3 \left(\frac{1}{r_p} \right)^{(k-1)/k} = (1400 \text{ R}) \left(\frac{1}{10} \right)^{0.4/1.4} = 725.1 \text{ R}$$

Since the work produced by expansion 3-4 equals that used by compression 1-2, an energy balance gives

$$T_4 = T_3 - (T_2 - T_1) = 1400 - (868.8 - 450) = 981.2 \text{ R}$$

The mass flow rate through the propeller is

$$\nu_1 = \frac{RT}{P} = \frac{(0.3704 \text{ psia}\cdot\text{ft}^3)(450 \text{ R})}{8 \text{ psia}} = 20.84 \text{ ft}^3/\text{lbm}$$

$$\dot{m}_p = \frac{AV_1}{\nu_1} = \frac{\pi D^2 V_1}{4 \nu_1} = \frac{\pi(8 \text{ ft})^2}{4} \frac{600 \text{ ft/s}}{20.84 \text{ ft}^3/\text{lbm}} = 1447 \text{ lbm/s}$$

According to the previous problem,

$$\dot{m}_e = \frac{\dot{m}_p}{20} = \frac{2261 \text{ lbm/s}}{20} = 113.1 \text{ lbm/s}$$

The excess enthalpy generated by expansion 4-5 is used to increase the kinetic energy of the flow through the propeller,

$$\dot{m}_e c_p (T_4 - T_5) = \dot{m}_p \frac{V_{\text{exit}}^2 - V_{\text{inlet}}^2}{2}$$

which when solved for the velocity at which the air leaves the propeller gives

$$\begin{aligned} V_{\text{exit}} &= \left[2 \frac{\dot{m}_e}{\dot{m}_p} c_p (T_4 - T_5) + V_{\text{inlet}}^2 \right]^{1/2} \\ &= \left[2 \frac{113.1 \text{ lbm/s}}{1447 \text{ lbm/s}} (0.24 \text{ Btu}/\text{lbm}\cdot\text{R})(981.2 - 725.1) \text{ R} \left(\frac{25,037 \text{ ft}^2/\text{s}^2}{1 \text{ Btu}/\text{lbm}} \right) + (600 \text{ ft/s})^2 \right]^{1/2} \\ &= 775.0 \text{ ft/s} \end{aligned}$$

The thrust force generated by this propeller is then

$$F = \dot{m}_p (V_{\text{exit}} - V_{\text{inlet}}) = (1447 \text{ lbm/s})(775 - 600) \text{ ft/s} \left(\frac{1 \text{ lbf}}{32.174 \text{ lbm}\cdot\text{ft/s}^2} \right) = \mathbf{7870 \text{ lbf}}$$

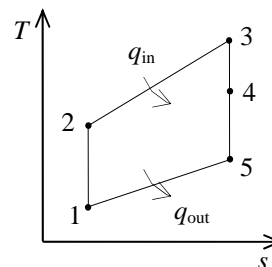

9-143 A turbofan engine operating on an ideal cycle produces 50,000 N of thrust. The air temperature at the fan outlet needed to produce this thrust is to be determined.

Assumptions 1 Steady operating conditions exist. 2 The air standard assumptions are applicable. 3 Air is an ideal gas with constant specific heats at room temperature. 4 The turbine work output is equal to the compressor work input.

Properties The properties of air at room temperature are $R = 0.287 \text{ kPa}\cdot\text{m}^3/\text{kg}\cdot\text{K}$, $c_p = 1.005 \text{ kJ/kg}\cdot\text{K}$ and $k = 1.4$ (Table A-2a).

Analysis The total mass flow rate is

$$\nu_1 = \frac{RT}{P} = \frac{(0.287 \text{ kPa}\cdot\text{m}^3)(253 \text{ K})}{50 \text{ kPa}} = 1.452 \text{ m}^3/\text{kg}$$

$$\dot{m} = \frac{AV_1}{\nu_1} = \frac{\pi D^2 V_1}{4 \nu_1} = \frac{\pi(2.5 \text{ m})^2}{4} \frac{200 \text{ m/s}}{1.452 \text{ m}^3/\text{kg}} = 676.1 \text{ kg/s}$$

Now,

$$\dot{m}_e = \frac{\dot{m}}{8} = \frac{676.1 \text{ kg/s}}{8} = 84.51 \text{ kg/s}$$

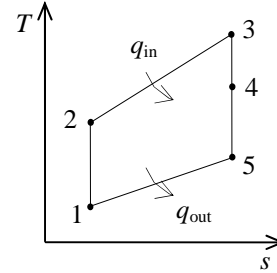

The mass flow rate through the fan is

$$\dot{m}_f = \dot{m} - \dot{m}_e = 676.1 - 84.51 = 591.6 \text{ kg/s}$$

In order to produce the specified thrust force, the velocity at the fan exit will be

$$F = \dot{m}_f (V_{\text{exit}} - V_{\text{inlet}})$$

$$V_{\text{exit}} = V_{\text{inlet}} + \frac{F}{\dot{m}_f} = (200 \text{ m/s}) + \frac{50,000 \text{ N}}{591.6 \text{ kg/s}} \left(\frac{1 \text{ kg}\cdot\text{m/s}^2}{1 \text{ N}} \right) = 284.5 \text{ m/s}$$

An energy balance on the stream passing through the fan gives

$$c_p (T_4 - T_5) = \frac{V_{\text{exit}}^2 - V_{\text{inlet}}^2}{2}$$

$$T_5 = T_4 - \frac{V_{\text{exit}}^2 - V_{\text{inlet}}^2}{2c_p}$$

$$= 253 \text{ K} - \frac{(284.5 \text{ m/s})^2 - (200 \text{ m/s})^2}{2(1.005 \text{ kJ/kg}\cdot\text{K})} \left(\frac{1 \text{ kJ/kg}}{1000 \text{ m}^2/\text{s}^2} \right)$$

$$= \mathbf{232.6 \text{ K}}$$

9-144 A pure jet engine operating on an ideal cycle is considered. The velocity at the nozzle exit and the thrust produced are to be determined.

Assumptions 1 Steady operating conditions exist. 2 The air standard assumptions are applicable. 3 Air is an ideal gas with constant specific heats at room temperature. 4 The turbine work output is equal to the compressor work input.

Properties The properties of air at room temperature are $R = 0.287 \text{ kPa}\cdot\text{m}^3/\text{kg}\cdot\text{K}$, $c_p = 1.005 \text{ kJ}/\text{kg}\cdot\text{K}$ and $k = 1.4$ (Table A-2a).

Analysis Working across the two isentropic processes of the cycle yields

$$T_2 = T_1 r_p^{(k-1)/k} = (273 \text{ K})(10)^{0.4/1.4} = 527.1 \text{ K}$$

$$T_5 = T_3 \left(\frac{1}{r_p} \right)^{(k-1)/k} = (723 \text{ K}) \left(\frac{1}{10} \right)^{0.4/1.4} = 374.5 \text{ K}$$

Since the work produced by expansion 3-4 equals that used by compression 1-2, an energy balance gives

$$T_4 = T_3 - (T_2 - T_1) = 723 - (527.1 - 273) = 468.9 \text{ K}$$

The excess enthalpy generated by expansion 4-5 is used to increase the kinetic energy of the flow through the propeller,

$$c_p (T_4 - T_5) = \frac{V_{\text{exit}}^2 - V_{\text{inlet}}^2}{2}$$

which when solved for the velocity at which the air leaves the propeller gives

$$\begin{aligned} V_{\text{exit}} &= \left[2c_p (T_4 - T_5) + V_{\text{inlet}}^2 \right]^{1/2} \\ &= \left[2(1.005 \text{ kJ}/\text{kg}\cdot\text{K})(468.9 - 374.5) \text{ K} \left(\frac{1000 \text{ m}^2/\text{s}^2}{1 \text{ kJ}/\text{kg}} \right) + (300 \text{ m/s})^2 \right]^{1/2} \\ &= \mathbf{528.9 \text{ m/s}} \end{aligned}$$

The mass flow rate through the engine is

$$\begin{aligned} \nu_1 &= \frac{RT}{P} = \frac{(0.287 \text{ kPa}\cdot\text{m}^3)(273 \text{ K})}{60 \text{ kPa}} = 1.306 \text{ m}^3/\text{kg} \\ \dot{m} &= \frac{AV_1}{\nu_1} = \frac{\pi D^2 V_1}{4 \nu_1} = \frac{\pi (2 \text{ m})^2}{4} \frac{300 \text{ m/s}}{1.306 \text{ m}^3/\text{kg}} = 721.7 \text{ kg/s} \end{aligned}$$

The thrust force generated is then

$$F = \dot{m}(V_{\text{exit}} - V_{\text{inlet}}) = (721.7 \text{ kg/s})(528.9 - 300) \text{ m/s} \left(\frac{1 \text{ N}}{1 \text{ kg}\cdot\text{m}/\text{s}^2} \right) = \mathbf{165,200 \text{ N}}$$

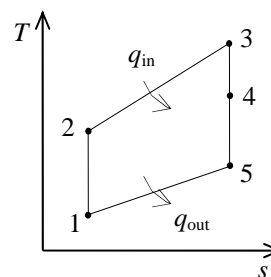

9-145 A turbojet aircraft flying at an altitude of 9150 m is operating on the ideal jet propulsion cycle. The velocity of exhaust gases, the propulsive power developed, and the rate of fuel consumption are to be determined.

Assumptions 1 Steady operating conditions exist. 2 The air standard assumptions are applicable. 3 Air is an ideal gas with constant specific heats at room temperature. 4 Kinetic and potential energies are negligible, except at the diffuser inlet and the nozzle exit. 5 The turbine work output is equal to the compressor work input.

Properties The properties of air at room temperature are $c_p = 1.005$ kJ/kg·K and $k = 1.4$ (Table A-2a).

Analysis (a) We assume the aircraft is stationary and the air is moving towards the aircraft at a velocity of $V_1 = 320$ m/s. Ideally, the air will leave the diffuser with a negligible velocity ($V_2 \cong 0$).

Diffuser:

$$\begin{aligned} \dot{E}_{\text{in}} - \dot{E}_{\text{out}} &= \Delta \dot{E}_{\text{system}}^{\phi_0 \text{ (steady)}} \longrightarrow \dot{E}_{\text{in}} = \dot{E}_{\text{out}} \\ h_1 + V_1^2 / 2 &= h_2 + V_2^2 / 2 \longrightarrow 0 = h_2 - h_1 + \frac{V_2^2 - V_1^2}{2} \\ 0 &= c_p (T_2 - T_1) - V_1^2 / 2 \\ T_2 &= T_1 + \frac{V_1^2}{2c_p} = 241 \text{ K} + \frac{(320 \text{ m/s})^2}{(2)(1.005 \text{ kJ/kg} \cdot \text{K})} \left(\frac{1 \text{ kJ/kg}}{1000 \text{ m}^2/\text{s}^2} \right) = 291.9 \text{ K} \\ P_2 &= P_1 \left(\frac{T_2}{T_1} \right)^{k/(k-1)} = (32 \text{ kPa}) \left(\frac{291.9 \text{ K}}{241 \text{ K}} \right)^{1.4/0.4} = 62.6 \text{ kPa} \end{aligned}$$

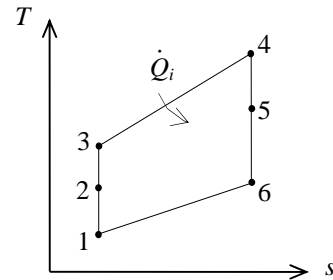

Compressor:

$$\begin{aligned} P_3 &= P_4 = (r_p)(P_2) = (12)(62.6 \text{ kPa}) = 751.2 \text{ kPa} \\ T_3 &= T_2 \left(\frac{P_3}{P_2} \right)^{(k-1)/k} = (291.9 \text{ K})(12)^{0.4/1.4} = 593.7 \text{ K} \end{aligned}$$

Turbine:

$$w_{\text{comp,in}} = w_{\text{turb,out}} \longrightarrow h_3 - h_2 = h_4 - h_5 \longrightarrow c_p (T_3 - T_2) = c_p (T_4 - T_5)$$

or

$$T_5 = T_4 - T_3 + T_2 = 1400 - 593.7 + 291.9 = 1098.2 \text{ K}$$

Nozzle:

$$\begin{aligned} T_6 &= T_4 \left(\frac{P_6}{P_4} \right)^{(k-1)/k} = (1400 \text{ K}) \left(\frac{32 \text{ kPa}}{751.2 \text{ kPa}} \right)^{0.4/1.4} = 568.2 \text{ K} \\ \dot{E}_{\text{in}} - \dot{E}_{\text{out}} &= \Delta \dot{E}_{\text{system}}^{\phi_0 \text{ (steady)}} \longrightarrow \dot{E}_{\text{in}} = \dot{E}_{\text{out}} \\ h_5 + V_5^2 / 2 &= h_6 + V_6^2 / 2 \\ 0 &= h_6 - h_5 + \frac{V_6^2 - V_5^2}{2} \longrightarrow 0 = c_p (T_6 - T_5) + V_6^2 / 2 \end{aligned}$$

or,

$$V_6 = \sqrt{(2)(1.005 \text{ kJ/kg} \cdot \text{K})(1098.2 - 568.2)\text{K} \left(\frac{1000 \text{ m}^2/\text{s}^2}{1 \text{ kJ/kg}} \right)} = \mathbf{1032 \text{ m/s}}$$

$$(b) \quad \dot{W}_p = \dot{m}(V_{\text{exit}} - V_{\text{inlet}})V_{\text{aircraft}} = (60 \text{ kg/s})(1032 - 320)\text{m/s}(320 \text{ m/s}) \left(\frac{1 \text{ kJ/kg}}{1000 \text{ m}^2/\text{s}^2} \right) = \mathbf{13,670 \text{ kW}}$$

$$(c) \quad \dot{Q}_{\text{in}} = \dot{m}(h_4 - h_3) = \dot{m}c_p(T_4 - T_3) = (60 \text{ kg/s})(1.005 \text{ kJ/kg} \cdot \text{K})(1400 - 593.7)\text{K} = 48,620 \text{ kJ/s}$$

$$\dot{m}_{\text{fuel}} = \frac{\dot{Q}_{\text{in}}}{\text{HV}} = \frac{48,620 \text{ kJ/s}}{42,700 \text{ kJ/kg}} = \mathbf{1.14 \text{ kg/s}}$$

9-146 A turbojet aircraft is flying at an altitude of 9150 m. The velocity of exhaust gases, the propulsive power developed, and the rate of fuel consumption are to be determined.

Assumptions 1 Steady operating conditions exist. **2** The air standard assumptions are applicable. **3** Air is an ideal gas with constant specific heats at room temperature. **4** Kinetic and potential energies are negligible, except at the diffuser inlet and the nozzle exit.

Properties The properties of air at room temperature are $c_p = 1.005 \text{ kJ/kg}\cdot\text{K}$ and $k = 1.4$ (Table A-2a).

Analysis (a) For convenience, we assume the aircraft is stationary and the air is moving towards the aircraft at a velocity of $V_1 = 320 \text{ m/s}$. Ideally, the air will leave the diffuser with a negligible velocity ($V_2 \cong 0$).

Diffuser:

$$\dot{E}_{\text{in}} - \dot{E}_{\text{out}} = \Delta \dot{E}_{\text{system}} \quad \phi^0 \text{ (steady)}$$

$$\dot{E}_{\text{in}} = \dot{E}_{\text{out}}$$

$$h_1 + V_1^2 / 2 = h_2 + V_2^2 / 2$$

$$0 = h_2 - h_1 + \frac{V_2^2 \phi^0 - V_1^2}{2}$$

$$0 = c_p (T_2 - T_1) - V_1^2 / 2$$

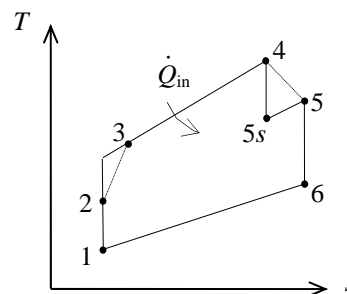

$$T_2 = T_1 + \frac{V_1^2}{2c_p} = 241 \text{ K} + \frac{(320 \text{ m/s})^2}{(2)(1.005 \text{ kJ/kg}\cdot\text{K})} \left(\frac{1 \text{ kJ/kg}}{1000 \text{ m}^2/\text{s}^2} \right) = 291.9 \text{ K}$$

$$P_2 = P_1 \left(\frac{T_2}{T_1} \right)^{k/(k-1)} = (32 \text{ kPa}) \left(\frac{291.9 \text{ K}}{241 \text{ K}} \right)^{1.4/0.4} = 62.6 \text{ kPa}$$

Compressor:

$$P_3 = P_4 = (r_p)(P_2) = (12)(62.6 \text{ kPa}) = 751.2 \text{ kPa}$$

$$T_{3s} = T_2 \left(\frac{P_3}{P_2} \right)^{(k-1)/k} = (291.9 \text{ K})(12)^{0.4/1.4} = 593.7 \text{ K}$$

$$\eta_C = \frac{h_{3s} - h_2}{h_3 - h_2} = \frac{c_p (T_{3s} - T_2)}{c_p (T_3 - T_2)}$$

$$T_3 = T_2 + (T_{3s} - T_2) / \eta_C = 291.9 + (593.7 - 291.9) / (0.80) = 669.2 \text{ K}$$

Turbine:

$$w_{\text{comp,in}} = w_{\text{turb,out}} \longrightarrow h_3 - h_2 = h_4 - h_5 \longrightarrow c_p (T_3 - T_2) = c_p (T_4 - T_5)$$

or,

$$T_5 = T_4 - T_3 + T_2 = 1400 - 669.2 + 291.9 = 1022.7 \text{ K}$$

$$\eta_T = \frac{h_4 - h_5}{h_4 - h_{5s}} = \frac{c_p (T_4 - T_5)}{c_p (T_4 - T_{5s})}$$

$$T_{5s} = T_4 - (T_4 - T_5) / \eta_T = 1400 - (1400 - 1022.7) / 0.85 = 956.1 \text{ K}$$

$$P_5 = P_4 \left(\frac{T_{5s}}{T_4} \right)^{k/(k-1)} = (751.2 \text{ kPa}) \left(\frac{956.1 \text{ K}}{1400 \text{ K}} \right)^{1.4/0.4} = 197.7 \text{ kPa}$$

Nozzle:

$$T_6 = T_5 \left(\frac{P_6}{P_5} \right)^{(k-1)/k} = (1022.7 \text{ K}) \left(\frac{32 \text{ kPa}}{197.7 \text{ kPa}} \right)^{0.4/1.4} = 607.8 \text{ K}$$

$$\dot{E}_{\text{in}} - \dot{E}_{\text{out}} = \Delta \dot{E}_{\text{system}} \stackrel{\neq 0}{\text{(steady)}}$$

$$\dot{E}_{\text{in}} = \dot{E}_{\text{out}}$$

$$h_5 + V_5^2 / 2 = h_6 + V_6^2 / 2$$

$$0 = h_6 - h_5 + \frac{V_6^2 - V_5^2}{2} \stackrel{\neq 0}{}$$

$$0 = c_p (T_6 - T_5) + V_6^2 / 2$$

or,

$$V_6 = \sqrt{(2)(1.005 \text{ kJ/kg} \cdot \text{K})(1022.7 - 607.8) \text{K} \left(\frac{1000 \text{ m}^2/\text{s}^2}{1 \text{ kJ/kg}} \right)} = \mathbf{913.2 \text{ m/s}}$$

$$\begin{aligned} (b) \quad \dot{W}_p &= \dot{m}(V_{\text{exit}} - V_{\text{inlet}}) V_{\text{aircraft}} \\ &= (60 \text{ kg/s})(913.2 - 320) \text{ m/s} (320 \text{ m/s}) \left(\frac{1 \text{ kJ/kg}}{1000 \text{ m}^2/\text{s}^2} \right) \\ &= \mathbf{11,390 \text{ kW}} \end{aligned}$$

$$(c) \quad \dot{Q}_{\text{in}} = \dot{m}(h_4 - h_3) = \dot{m} c_p (T_4 - T_3) = (60 \text{ kg/s})(1.005 \text{ kJ/kg} \cdot \text{K})(1400 - 669.2) \text{K} = 44,067 \text{ kJ/s}$$

$$\dot{m}_{\text{fuel}} = \frac{\dot{Q}_{\text{in}}}{\text{HV}} = \frac{44,067 \text{ kJ/s}}{42,700 \text{ kJ/kg}} = \mathbf{1.03 \text{ kg/s}}$$

9-147 A turbojet aircraft that has a pressure ratio of 12 is stationary on the ground. The force that must be applied on the brakes to hold the plane stationary is to be determined.

Assumptions 1 Steady operating conditions exist. 2 The air standard assumptions are applicable. 3 Air is an ideal gas with variable specific heats. 4 Kinetic and potential energies are negligible, except at the nozzle exit.

Properties The properties of air are given in Table A17.

Analysis (a) Using variable specific heats for air,

Compressor:

$$T_1 = 300 \text{ K} \longrightarrow h_1 = 300.19 \text{ kJ/kg}$$

$$P_{r_1} = 1.386$$

$$P_{r_2} = \frac{P_2}{P_1} P_{r_1} = (12)(1.386) = 16.63 \longrightarrow h_2 = 610.65 \text{ kJ/kg}$$

$$\dot{Q}_{\text{in}} = \dot{m}_{\text{fuel}} \times \text{HV} = (0.2 \text{ kg/s})(42,700 \text{ kJ/kg}) = 8540 \text{ kJ/s}$$

$$q_{\text{in}} = \frac{\dot{Q}_{\text{in}}}{\dot{m}} = \frac{8540 \text{ kJ/s}}{10 \text{ kg/s}} = 854 \text{ kJ/kg}$$

$$q_{\text{in}} = h_3 - h_2 \longrightarrow h_3 = h_2 + q_{\text{in}} = 610.65 + 854 = 1464.65 \text{ kJ/kg}$$

$$\longrightarrow P_{r_3} = 396.27$$

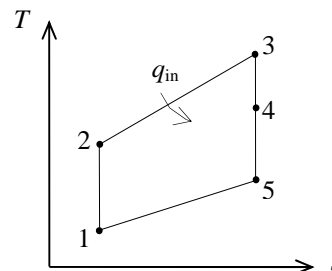

Turbine:

$$w_{\text{comp,in}} = w_{\text{turb,out}} \longrightarrow h_2 - h_1 = h_3 - h_4$$

or,

$$h_4 = h_3 - h_2 + h_1 = 1464.65 - 610.65 + 300.19 = 741.17 \text{ kJ/kg}$$

Nozzle:

$$P_{r_5} = P_{r_3} \left(\frac{P_5}{P_3} \right) = (396.27) \left(\frac{1}{12} \right) = 33.02 \longrightarrow h_5 = 741.79 \text{ kJ/kg}$$

$$\dot{E}_{\text{in}} - \dot{E}_{\text{out}} = \Delta \dot{E}_{\text{system}}^{\phi_0} \text{ (steady)}$$

$$\dot{E}_{\text{in}} = \dot{E}_{\text{out}}$$

$$h_4 + V_4^2 / 2 = h_5 + V_5^2 / 2$$

$$0 = h_5 - h_4 + \frac{V_5^2 - V_4^2}{2}$$

or,

$$V_5 = \sqrt{2(h_4 - h_5)} = \sqrt{(2)(1154.19 - 741.17) \text{ kJ/kg} \left(\frac{1000 \text{ m}^2/\text{s}^2}{1 \text{ kJ/kg}} \right)} = 908.9 \text{ m/s}$$

$$\text{Brake force} = \text{Thrust} = \dot{m}(V_{\text{exit}} - V_{\text{inlet}}) = (10 \text{ kg/s})(908.9 - 0) \text{ m/s} \left(\frac{1 \text{ N}}{1 \text{ kg} \cdot \text{m/s}^2} \right) = \mathbf{9089 \text{ N}}$$

9-148 EES Problem 9-147 is reconsidered. The effect of compressor inlet temperature on the force that must be applied to the brakes to hold the plane stationary is to be investigated.

Analysis Using EES, the problem is solved as follows:

```
P_ratio = 12
T_1 = 27 [C]
T[1] = T_1+273 "[K]"
P[1]= 95 [kPa]
P[5]=P[1]
Vel[1]=0 [m/s]
V_dot[1] = 9.063 [m^3/s]
HV_fuel = 42700 [kJ/kg]
m_dot_fuel = 0.2 [kg/s]
Eta_c = 1.0
Eta_t = 1.0
Eta_N = 1.0
```

"Inlet conditions"

```
h[1]=ENTHALPY(Air,T=T[1])
s[1]=ENTROPY(Air,T=T[1],P=P[1])
v[1]=volume(Air,T=T[1],P=P[1])
m_dot = V_dot[1]/v[1]
```

"Compressor analysis"

```
s_s[2]=s[1] "For the ideal case the entropies are constant across the compressor"
P_ratio=P[2]/P[1]"Definition of pressure ratio - to find P[2]"
T_s[2]=TEMPERATURE(Air,s=s_s[2],P=P[2]) "T_s[2] is the isentropic value of T[2] at
compressor exit"
h_s[2]=ENTHALPY(Air,T=T_s[2])
Eta_c =(h_s[2]-h[1])/(h[2]-h[1]) "Compressor adiabatic efficiency; Eta_c =
W_dot_c_ideal/W_dot_c_actual. "
m_dot*h[1] +W_dot_c=m_dot*h[2] "SSSF First Law for the actual compressor, assuming:
adiabatic, ke=pe=0"
```

"External heat exchanger analysis"

```
P[3]=P[2]"process 2-3 is SSSF constant pressure"
h[3]=ENTHALPY(Air,T=T[3])
Q_dot_in = m_dot_fuel*HV_fuel
m_dot*h[2] + Q_dot_in= m_dot*h[3]"SSSF First Law for the heat exchanger, assuming W=0,
ke=pe=0"
```

"Turbine analysis"

```
s[3]=ENTROPY(Air,T=T[3],P=P[3])
s_s[4]=s[3] "For the ideal case the entropies are constant across the turbine"
{P_ratio= P[3] /P[4]}
T_s[4]=TEMPERATURE(Air,h=h_s[4]) "Ts[4] is the isentropic value of T[4] at turbine exit"
{h_s[4]=ENTHALPY(Air,T=T_s[4])} "Eta_t = W_dot_t /Wts_dot turbine adiabatic efficiency,
Wts_dot > W_dot_t"
Eta_t=(h[3]-h[4])/(h[3]-h_s[4])
m_dot*h[3] = W_dot_t + m_dot*h[4] "SSSF First Law for the actual compressor, assuming:
adiabatic, ke=pe=0"
T[4]=TEMPERATURE(Air,h=h[4])
P[4]=pressure(Air,s=s_s[4],h=h_s[4])
```

"Cycle analysis"

```
W_dot_net=W_dot_t-W_dot_c"Definition of the net cycle work, kW"
W_dot_net = 0 [kW]
```

"Exit nozzle analysis:"

s[4]=entropy('air',T=T[4],P=P[4])

s_s[5]=s[4] "For the ideal case the entropies are constant across the nozzle"

T_s[5]=TEMPERATURE(Air,s=s_s[5], P=P[5]) "T_s[5] is the isentropic value of T[5] at nozzle exit"

h_s[5]=ENTHALPY(Air,T=T_s[5])

Eta_N=(h[4]-h[5])/(h[4]-h_s[5])

m_dot*h[4] = m_dot*(h_s[5] + Vel_s[5]^2/2*convert(m^2/s^2,kJ/kg))

m_dot*h[4] = m_dot*(h[5] + Vel[5]^2/2*convert(m^2/s^2,kJ/kg))

T[5]=TEMPERATURE(Air,h=h[5])

s[5]=entropy('air',T=T[5],P=P[5])

"Brake Force to hold the aircraft:"

Thrust = m_dot*(Vel[5] - Vel[1]) "[N]"

BrakeForce = Thrust "[N]"

"The following state points are determined only to produce a T-s plot"

T[2]=temperature('air',h=h[2])

s[2]=entropy('air',T=T[2],P=P[2])

Brake Force [N]	m [kg/s]	T ₃ [K]	T ₁ [C]
9971	11.86	1164	-20
9764	11.41	1206	-10
9568	10.99	1247	0
9383	10.6	1289	10
9207	10.24	1330	20
9040	9.9	1371	30

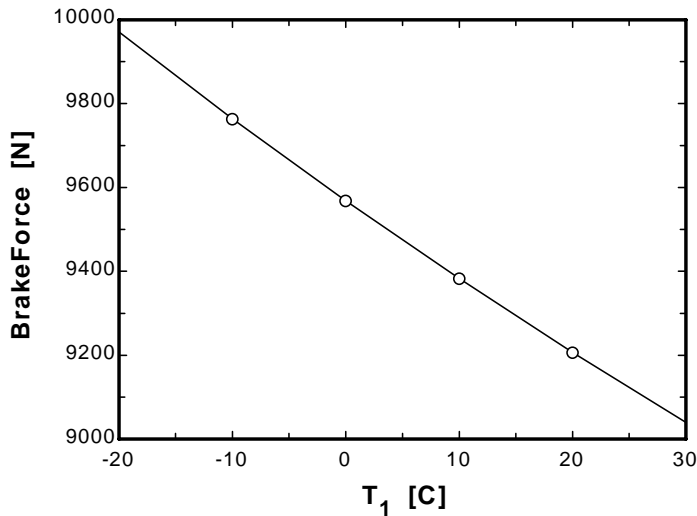
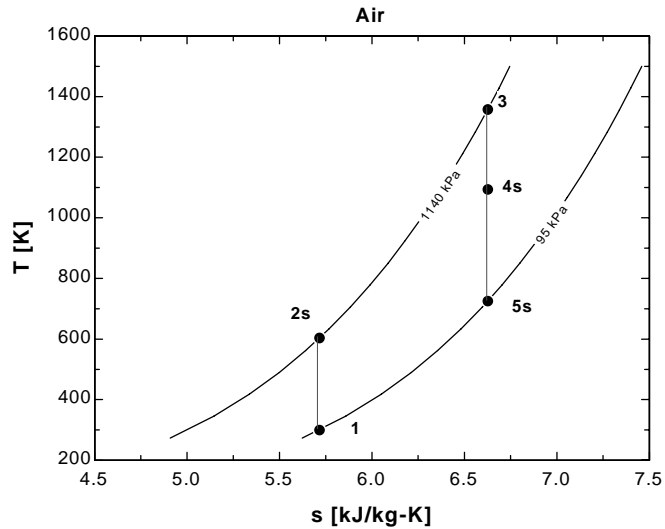

9-149 Air enters a turbojet engine. The thrust produced by this turbojet engine is to be determined.

Assumptions 1 Steady operating conditions exist. 2 The air standard assumptions are applicable. 3 Air is an ideal gas with variable specific heats. 4 Kinetic and potential energies are negligible, except at the diffuser inlet and the nozzle exit.

Properties The properties of air are given in Table A-17.

Analysis We assume the aircraft is stationary and the air is moving towards the aircraft at a velocity of $V_1 = 300$ m/s. Taking the entire engine as our control volume and writing the steady-flow energy balance yield

$$T_1 = 280 \text{ K} \quad \longrightarrow \quad h_1 = 280.13 \text{ kJ/kg}$$

$$T_2 = 700 \text{ K} \quad \longrightarrow \quad h_2 = 713.27 \text{ kJ/kg}$$

$$\dot{E}_{\text{in}} - \dot{E}_{\text{out}} = \Delta \dot{E}_{\text{system}}^{\text{net}} \quad \text{(\text{steady})}$$

$$\dot{E}_{\text{in}} = \dot{E}_{\text{out}}$$

$$\dot{Q}_{\text{in}} + \dot{m}(h_1 + V_1^2 / 2) = \dot{m}(h_2 + V_2^2 / 2)$$

$$\dot{Q}_{\text{in}} = \dot{m} \left(h_2 - h_1 + \frac{V_2^2 - V_1^2}{2} \right)$$

$$15,000 \text{ kJ/s} = (16 \text{ kg/s}) \left[713.27 - 280.13 + \frac{V_2^2 - (300 \text{ m/s})^2}{2} \left(\frac{1 \text{ kJ/kg}}{1000 \text{ m}^2/\text{s}^2} \right) \right]$$

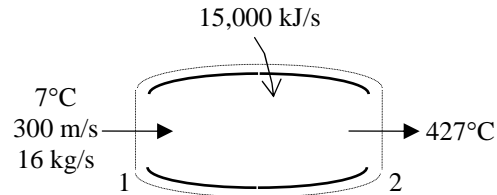

It gives

$$V_2 = 1048 \text{ m/s}$$

Thus,

$$F_p = \dot{m}(V_2 - V_1) = (16 \text{ kg/s})(1048 - 300) \text{ m/s} = \mathbf{11,968 \text{ N}}$$

Second-Law Analysis of Gas Power Cycles

9-150E The exergy destruction associated with the heat rejection process of the Diesel cycle described in Prob. 9-60 and the exergy at the end of the expansion stroke are to be determined.

Analysis From Prob. 9-60E, $q_{\text{out}} = 158.9 \text{ Btu/lbm}$, $T_1 = 540 \text{ R}$, $T_4 = 1420.6 \text{ R}$, and $\nu_4 = \nu_1$. At $T_{\text{avg}} = (T_4 + T_1)/2 = (1420.6 + 540)/2 = 980.3 \text{ R}$, we have $c_{\nu, \text{avg}} = 0.180 \text{ Btu/lbm}\cdot\text{R}$. The entropy change during process 4-1 is

$$s_1 - s_4 = c_{\nu} \ln \frac{T_1}{T_4} + R \ln \frac{\nu_1}{\nu_4} \stackrel{\nu_1 = \nu_4}{=} (0.180 \text{ Btu/lbm}\cdot\text{R}) \ln \frac{540 \text{ R}}{1420.6 \text{ R}} = -0.1741 \text{ Btu/lbm}\cdot\text{R}$$

Thus,

$$x_{\text{destroyed}, 41} = T_0 \left(s_1 - s_4 + \frac{q_{R,41}}{T_R} \right) = (540 \text{ R}) \left(-0.1741 \text{ Btu/lbm}\cdot\text{R} + \frac{158.9 \text{ Btu/lbm}}{540 \text{ R}} \right) = \mathbf{64.9 \text{ Btu/lbm}}$$

Noting that state 4 is identical to the state of the surroundings, the exergy at the end of the power stroke (state 4) is determined from

$$\phi_4 = (u_4 - u_0) - T_0 (s_4 - s_0) + P_0 (\nu_4 - \nu_0)$$

where

$$u_4 - u_0 = u_4 - u_1 = q_{\text{out}} = 158.9 \text{ Btu/lbm}\cdot\text{R}$$

$$\nu_4 - \nu_0 = \nu_4 - \nu_1 = 0$$

$$s_4 - s_0 = s_4 - s_1 = 0.1741 \text{ Btu/lbm}\cdot\text{R}$$

Thus,

$$\phi_4 = (158.9 \text{ Btu/lbm}) - (540 \text{ R})(0.1741 \text{ Btu/lbm}\cdot\text{R}) + 0 = \mathbf{64.9 \text{ Btu/lbm}}$$

Discussion Note that the exergy at state 4 is identical to the exergy destruction for the process 4-1 since state 1 is identical to the dead state, and the entire exergy at state 4 is wasted during process 4-1.

9-151 The exergy destruction associated with each of the processes of the Brayton cycle described in Prob. 9-91 is to be determined.

Analysis From Prob. 9-91, $q_{in} = 584.62 \text{ kJ/kg}$, $q_{out} = 478.92 \text{ kJ/kg}$, and

$$T_1 = 310\text{K} \longrightarrow s_1^\circ = 1.73498\text{kJ/kg} \cdot \text{K}$$

$$h_2 = 646.3\text{kJ/kg} \longrightarrow s_2^\circ = 2.47256\text{kJ/kg} \cdot \text{K}$$

$$T_3 = 1160\text{K} \longrightarrow s_3^\circ = 3.13916\text{kJ/kg} \cdot \text{K}$$

$$h_4 = 789.16\text{kJ/kg} \longrightarrow s_4^\circ = 2.67602\text{kJ/kg} \cdot \text{K}$$

Thus,

$$\begin{aligned} x_{\text{destroyed},12} &= T_0 s_{\text{gen},12} = T_0 (s_2 - s_1) = T_0 \left(s_2^\circ - s_1^\circ - R \ln \frac{P_2}{P_1} \right) = \\ &= (310 \text{ K}) (2.47256 - 1.73498 - (0.287 \text{ kJ/kg} \cdot \text{K}) \ln(8)) = \mathbf{43.6 \text{ kJ/kg}} \\ x_{\text{destroyed},23} &= T_0 s_{\text{gen},23} = T_0 \left(s_3 - s_2 + \frac{q_{R,23}}{T_R} \right) = T_0 \left(s_3^\circ - s_2^\circ - R \ln \frac{P_3}{P_2} + \frac{-q_{in}}{T_H} \right) \\ &= (310 \text{ K}) \left(3.13916 - 2.47256 - \frac{584.62 \text{ kJ/kg}}{1600 \text{ K}} \right) = \mathbf{93.4 \text{ kJ/kg}} \\ x_{\text{destroyed},34} &= T_0 s_{\text{gen},34} = T_0 (s_4 - s_3) = T_0 \left(s_4^\circ - s_3^\circ - R \ln \frac{P_4}{P_3} \right) = \\ &= (310 \text{ K}) (2.67602 - 3.13916 - (0.287 \text{ kJ/kg} \cdot \text{K}) \ln(1/8)) = \mathbf{41.4 \text{ kJ/kg}} \\ x_{\text{destroyed},41} &= T_0 s_{\text{gen},41} = T_0 \left(s_1 - s_4 + \frac{q_{R,41}}{T_R} \right) = T_0 \left(s_1^\circ - s_4^\circ - R \ln \frac{P_1}{P_4} + \frac{q_{out}}{T_L} \right) \\ &= (310 \text{ K}) \left(1.73498 - 2.67602 + \frac{478.92 \text{ kJ/kg}}{310 \text{ K}} \right) = \mathbf{220 \text{ kJ/kg}} \end{aligned}$$

9-152E The exergy loss of an ideal dual cycle described in Prob. 9-58E is to be determined.

Analysis From Prob. 9-58E, $q_{out} = 66.48$ Btu/lbm, $T_1 = 530$ R, $T_2 = 1757$ R, $T_x = 2109$ R, $T_3 = 2742$ R, and $T_4 = 918.8$ R. Also,

$$q_{in,2-x} = c_v(T_x - T_2) = (0.171 \text{ Btu/lbm} \cdot \text{R})(2109 - 1757)\text{R} = 60.19 \text{ Btu/lbm}$$

$$q_{in,x-3} = c_v(T_3 - T_x) = (0.240 \text{ Btu/lbm} \cdot \text{R})(2742 - 2109)\text{R} = 151.9 \text{ Btu/lbm}$$

$$q_{out} = c_v(T_4 - T_1) = (0.718 \text{ kJ/kg} \cdot \text{K})(494.8 - 291)\text{K} = 146.3 \text{ kJ/kg}$$

The exergy destruction during a process of the cycle is

$$x_{dest} = T_0 s_{gen} = T_0 \left(\Delta s - \frac{q_{in}}{T_{source}} + \frac{q_{out}}{T_{sink}} \right)$$

Application of this equation for each process of the cycle gives

$$x_{dest,1-2} = 0 \quad (\text{isentropic process})$$

$$s_x - s_2 = c_v \ln \frac{T_x}{T_2} + R \ln \frac{v_x}{v_2}$$

$$= (0.171 \text{ Btu/lbm} \cdot \text{R}) \ln \frac{2109 \text{ R}}{1757 \text{ R}} + 0 = 0.03123 \text{ Btu/lbm} \cdot \text{R}$$

$$x_{dest,2-x} = T_0 \left(s_x - s_2 - \frac{q_{in,2-x}}{T_{source}} \right) = (530 \text{ R}) \left(0.03123 \text{ Btu/lbm} \cdot \text{R} - \frac{60.19 \text{ Btu/lbm}}{2742 \text{ R}} \right) = 4.917 \text{ Btu/lbm}$$

$$s_3 - s_x = c_p \ln \frac{T_3}{T_x} - R \ln \frac{P_3}{P_x} = (0.240 \text{ Btu/lbm} \cdot \text{R}) \ln \frac{2742 \text{ R}}{2109 \text{ R}} - 0 = 0.06299 \text{ Btu/lbm} \cdot \text{R}$$

$$x_{dest,x-3} = T_0 \left(s_3 - s_x - \frac{q_{in,x-3}}{T_{source}} \right) = (530 \text{ R}) \left(0.06299 \text{ Btu/lbm} \cdot \text{R} - \frac{151.9 \text{ Btu/lbm}}{2742 \text{ R}} \right) = 4.024 \text{ Btu/lbm}$$

$$x_{dest,3-4} = 0 \quad (\text{isentropic process})$$

$$s_1 - s_4 = c_v \ln \frac{T_1}{T_4} + R \ln \frac{v_1}{v_4} = (0.171 \text{ Btu/lbm} \cdot \text{R}) \ln \frac{530 \text{ R}}{918.8 \text{ R}} + 0 = -0.09408 \text{ Btu/lbm} \cdot \text{R}$$

$$x_{dest,4-1} = T_0 \left(s_1 - s_4 + \frac{q_{out}}{T_{sink}} \right) = (530 \text{ R}) \left(-0.09408 \text{ Btu/lbm} \cdot \text{R} + \frac{66.48 \text{ Btu/lbm}}{530 \text{ R}} \right) = 16.62 \text{ Btu/lbm}$$

The largest exergy destruction in the cycle occurs during the heat-rejection process

s. The total exergy destruction in the cycle is

$$x_{dest,total} = 4.917 + 4.024 + 16.62 = \mathbf{25.6 \text{ Btu/lbm}}$$

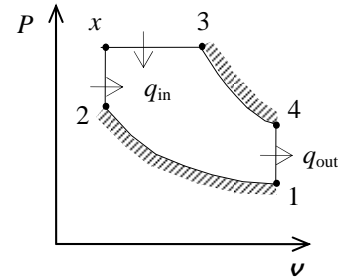

9-153E The entropy generated by the Brayton cycle of Prob. 9-102E is to be determined.

Analysis From Prob. 9-102E,

$$\begin{aligned}\dot{Q}_{\text{in}} &= 2356 \text{ Btu/s} \\ \dot{Q}_{\text{out}} &= \dot{Q}_{\text{in}} - \dot{W}_{\text{net}} = 2356 - 1417 = 939 \text{ Btu/s} \\ T_H &= 1660 \text{ R} \\ T_L &= 540 \text{ R}\end{aligned}$$

No entropy is generated by the working fluid since it always returns to its original state. Then,

$$\dot{S}_{\text{gen}} = \frac{\dot{Q}_{\text{out}}}{T_L} - \frac{\dot{Q}_{\text{in}}}{T_H} = \frac{939 \text{ Btu/s}}{540 \text{ R}} - \frac{2356 \text{ Btu/s}}{1660 \text{ R}} = \mathbf{0.320 \text{ Btu/s} \cdot \text{R}}$$

9-154 The exergy loss of each process for a regenerative Brayton cycle described in Prob. 9-112 is to be determined.

Analysis From Prob. 9-112, $T_1 = 293 \text{ K}$, $T_2 = 566.3 \text{ K}$, $T_3 = 1073 \text{ K}$, $T_4 = 625.9 \text{ K}$, $T_5 = 615.9 \text{ K}$, $T_6 = 576.3 \text{ K}$, and $r_p = 8$.

Also,

$$\begin{aligned}q_{\text{in}} &= c_p(T_3 - T_5) = (1.005 \text{ kJ/kg} \cdot \text{K})(1073 - 615.9) \text{ K} = 659.4 \text{ kJ/kg} \\ q_{\text{out}} &= c_p(T_6 - T_1) = (1.005 \text{ kJ/kg} \cdot \text{K})(576.3 - 293) \text{ K} = 284.7 \text{ kJ/kg}\end{aligned}$$

The exergy destruction during a process of a stream from an inlet state to exit state is given by

$$x_{\text{dest}} = T_0 s_{\text{gen}} = T_0 \left(s_e - s_i - \frac{q_{\text{in}}}{T_{\text{source}}} + \frac{q_{\text{out}}}{T_{\text{sink}}} \right)$$

Application of this equation for each process of the cycle gives

$$x_{\text{dest}, 1-2} = T_0 \left(c_p \ln \frac{T_2}{T_1} - R \ln \frac{P_2}{P_1} \right) = (293) \left[(1.005) \ln \frac{566.3}{293} - (0.287) \ln(8) \right] = \mathbf{19.2 \text{ kJ/kg}}$$

$$x_{\text{dest}, 5-3} = T_0 \left(c_p \ln \frac{T_3}{T_5} - R \ln \frac{P_3}{P_5} - \frac{q_{\text{in}}}{T_{\text{source}}} \right) = (293) \left[(1.005) \ln \frac{1073}{615.9} - 0 - \frac{459.4}{1073} \right] = \mathbf{38.0 \text{ kJ/kg}}$$

$$x_{\text{dest}, 3-4} = T_0 \left(c_p \ln \frac{T_4}{T_3} - R \ln \frac{P_4}{P_3} \right) = (293 \text{ K}) \left[(1.005) \ln \frac{625.9}{1073} - (0.287) \ln \left(\frac{1}{8} \right) \right] = \mathbf{16.1 \text{ kJ/kg}}$$

$$x_{\text{dest}, 6-1} = T_0 \left(c_p \ln \frac{T_1}{T_6} - R \ln \frac{P_1}{P_6} + \frac{q_{\text{out}}}{T_{\text{sink}}} \right) = (293) \left[(1.005) \ln \frac{293}{576.3} - 0 + \frac{284.7}{293} \right] = \mathbf{85.5 \text{ kJ/kg}}$$

$$\begin{aligned}x_{\text{dest}, \text{regen}} &= T_0 (\Delta s_{2-5} + \Delta s_{4-6}) = T_0 \left(c_p \ln \frac{T_5}{T_2} + c_p \ln \frac{T_6}{T_4} \right) \\ &= (293) \left[(1.005) \ln \frac{615.9}{566.3} + (1.005) \ln \frac{576.3}{625.9} \right] = \mathbf{0.41 \text{ kJ/kg}}\end{aligned}$$

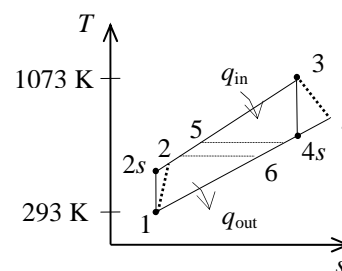

9-155 The total exergy destruction associated with the Brayton cycle described in Prob. 9-119 and the exergy at the exhaust gases at the turbine exit are to be determined.

Properties The gas constant of air is $R = 0.287 \text{ kJ/kg}\cdot\text{K}$ (Table A-1).

Analysis From Prob. 9-119, $q_{\text{in}} = 480.82$, $q_{\text{out}} = 372.73 \text{ kJ/kg}$, and

$$\begin{aligned} T_1 = 310 \text{ K} &\longrightarrow s_1^\circ = 1.73498 \text{ kJ/kg}\cdot\text{K} \\ h_2 = 618.26 \text{ kJ/kg} &\longrightarrow s_2^\circ = 2.42763 \text{ kJ/kg}\cdot\text{K} \\ T_3 = 1150 \text{ K} &\longrightarrow s_3^\circ = 3.12900 \text{ kJ/kg}\cdot\text{K} \\ h_4 = 803.14 \text{ kJ/kg} &\longrightarrow s_4^\circ = 2.69407 \text{ kJ/kg}\cdot\text{K} \\ h_5 = 738.43 \text{ kJ/kg} &\longrightarrow s_5^\circ = 2.60815 \text{ kJ/kg}\cdot\text{K} \end{aligned}$$

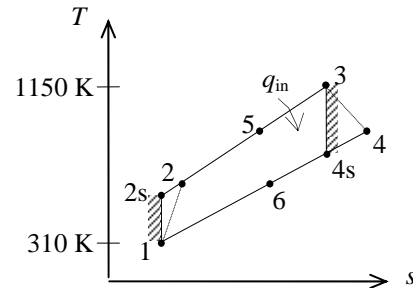

and, from an energy balance on the heat exchanger,

$$\begin{aligned} h_5 - h_2 = h_4 - h_6 &\longrightarrow h_6 = 803.14 - (738.43 - 618.26) = 682.97 \text{ kJ/kg} \\ &\longrightarrow s_6^\circ = 2.52861 \text{ kJ/kg}\cdot\text{K} \end{aligned}$$

Thus,

$$\begin{aligned} x_{\text{destroyed},12} &= T_0 s_{\text{gen},12} = T_0 (s_2 - s_1) = T_0 \left(s_2^\circ - s_1^\circ - R \ln \frac{P_2}{P_1} \right) \\ &= (310 \text{ K}) (2.42763 - 1.73498 - (0.287 \text{ kJ/kg}\cdot\text{K}) \ln(7)) = \mathbf{41.59 \text{ kJ/kg}} \\ x_{\text{destroyed},34} &= T_0 s_{\text{gen},34} = T_0 (s_4 - s_3) = T_0 \left(s_4^\circ - s_3^\circ - R \ln \frac{P_4}{P_3} \right) \\ &= (310 \text{ K}) (2.69407 - 3.12900 - (0.287 \text{ kJ/kg}\cdot\text{K}) \ln(1/7)) = \mathbf{38.30 \text{ kJ/kg}} \\ x_{\text{destroyed,regen}} &= T_0 s_{\text{gen,regen}} = T_0 [(s_5 - s_2) + (s_6 - s_4)] = T_0 [(s_5^\circ - s_2^\circ) + (s_6^\circ - s_4^\circ)] \\ &= (310 \text{ K}) (2.60815 - 2.42763 + 2.52861 - 2.69407) = \mathbf{4.67 \text{ kJ/kg}} \\ x_{\text{destroyed},53} &= T_0 s_{\text{gen},53} = T_0 \left(s_3 - s_5 - \frac{q_{R,53}}{T_R} \right) = T_0 \left(s_3^\circ - s_5^\circ - R \ln \frac{P_3}{P_5} - \frac{q_{\text{in}}}{T_H} \right) \\ &= (310 \text{ K}) \left(3.12900 - 2.60815 - \frac{480.82 \text{ kJ/kg}}{1800 \text{ K}} \right) = \mathbf{78.66 \text{ kJ/kg}} \\ x_{\text{destroyed},61} &= T_0 s_{\text{gen},61} = T_0 \left(s_1 - s_6 + \frac{q_{R,61}}{T_R} \right) = T_0 \left(s_1^\circ - s_6^\circ - R \ln \frac{P_1}{P_6} + \frac{q_{\text{out}}}{T_L} \right) \\ &= (310 \text{ K}) \left(1.73498 - 2.52861 + \frac{372.73 \text{ kJ/kg}}{310 \text{ K}} \right) = \mathbf{126.7 \text{ kJ/kg}} \end{aligned}$$

Noting that $h_0 = h_{@ 310 \text{ K}} = 310.24 \text{ kJ/kg}$, the stream exergy at the exit of the regenerator (state 6) is determined from

$$\phi_6 = (h_6 - h_0) - T_0 (s_6 - s_0) + \frac{V_6^2}{2} + gz_6$$

$$\text{where } s_6 - s_0 = s_6 - s_1 = s_6^\circ - s_1^\circ - R \ln \frac{P_6}{P_1} = 2.52861 - 1.73498 = 0.79363 \text{ kJ/kg}\cdot\text{K}$$

$$\text{Thus, } \phi_6 = 682.97 - 310.24 - (310 \text{ K})(0.79363 \text{ kJ/kg}\cdot\text{K}) = \mathbf{126.7 \text{ kJ/kg}}$$

9-156 EES Prob. 9-155 is reconsidered. The effect of the cycle pressure on the total irreversibility for the cycle and the exergy of the exhaust gas leaving the regenerator is to be investigated.

Analysis Using EES, the problem is solved as follows:

"Given"

```
T[1]=310 [K]
P[1]=100 [kPa]
Ratio_P=7
P[2]=Ratio_P*P[1]
T[3]=1150 [K]
eta_C=0.75
eta_T=0.82
epsilon=0.65
T_H=1800 [K]
T0=310 [K]
P0=100 [kPa]
```

"Analysis for Problem 9-156"

```
q_in=h[3]-h[5]
q_out=h[6]-h[1]
h[5]-h[2]=h[4]-h[6]
s[2]=entropy(Fluid$, P=P[2], h=h[2])
s[4]=entropy(Fluid$, h=h[4], P=P[4])
s[5]=entropy(Fluid$, h=h[5], P=P[5])
P[5]=P[2]
s[6]=entropy(Fluid$, h=h[6], P=P[6])
P[6]=P[1]
h[0]=enthalpy(Fluid$, T=T0)
s[0]=entropy(Fluid$, T=T0, P=P0)
x_destroyed_12=T0*(s[2]-s[1])
x_destroyed_34=T0*(s[4]-s[3])
x_destroyed_regen=T0*(s[5]-s[2]+s[6]-s[4])
x_destroyed_53=T0*(s[3]-s[5]-q_in/T_H)
x_destroyed_61=T0*(s[1]-s[6]+q_out/T0)
x_total=x_destroyed_12+x_destroyed_34+x_destroyed_regen+x_destroyed_53+x_destroyed_61
x6=h[6]-h[0]-T0*(s[6]-s[0]) "since state 0 and state 1 are identical"
```

"Analysis for Problem 9-119"

```
Fluid$='air'
"(a)"
h[1]=enthalpy(Fluid$, T=T[1])
s[1]=entropy(Fluid$, T=T[1], P=P[1])
s_s[2]=s[1] "isentropic compression"
h_s[2]=enthalpy(Fluid$, P=P[2], s=s_s[2])
eta_C=(h_s[2]-h[1])/(h[2]-h[1])
h[3]=enthalpy(Fluid$, T=T[3])
s[3]=entropy(Fluid$, T=T[3], P=P[3])
P[3]=P[2]
s_s[4]=s[3] "isentropic expansion"
h_s[4]=enthalpy(Fluid$, P=P[4], s=s_s[4])
P[4]=P[1]
eta_T=(h[3]-h[4])/(h[3]-h_s[4])
q_regen=epsilon*(h[4]-h[2])
```

"(b)"

$$w_{C_in} = (h[2] - h[1])$$

$$w_{T_out} = h[3] - h[4]$$

$$w_{net_out} = w_{T_out} - w_{C_in}$$

$$q_{in} = (h[3] - h[2]) - q_{regen}$$

$$\eta_{th} = w_{net_out} / q_{in}$$

Ratio_P	x_{total} [kJ/kg]	x_6 [kJ/kg]
6	279.8	120.7
7	289.9	126.7
8	299.8	132.5
9	309.5	138
10	318.8	143.4
11	327.9	148.6
12	336.7	153.7
13	345.2	158.6
14	353.4	163.4

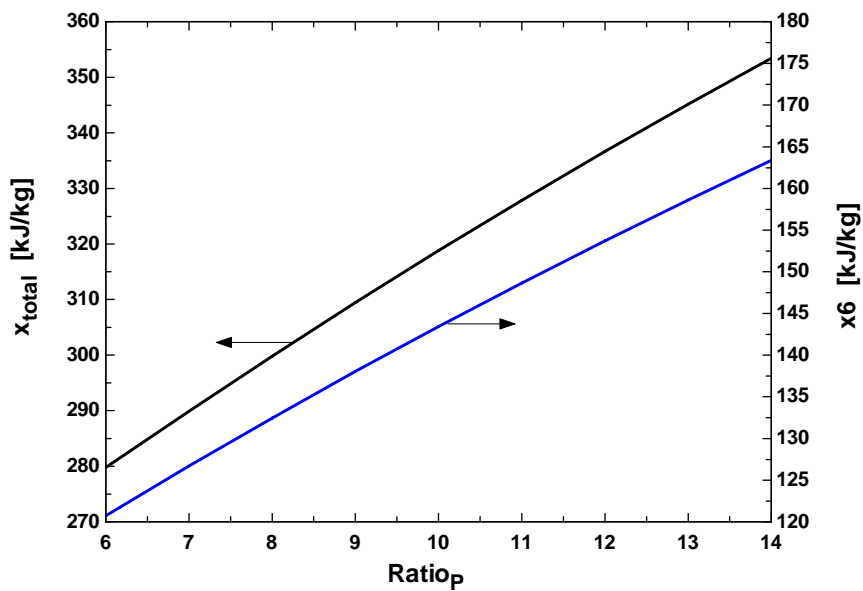

9-157E The exergy loss of each process for a reheat-regenerative Brayton cycle with intercooling described in Prob. 9-134E is to be determined.

Analysis From Prob. 9-134E,

$$T_1 = T_3 = 520 \text{ R},$$

$$T_2 = T_4 = T_{10} = 737.8 \text{ R},$$

$$T_5 = T_7 = T_9 = 1049 \text{ K},$$

$$T_6 = T_8 = 1400 \text{ R}, \text{ and } r_p = 3.$$

Also,

$$\begin{aligned} q_{\text{in},5-6} &= q_{\text{in},7-8} = c_p (T_6 - T_5) \\ &= (0.240 \text{ Btu/lbm} \cdot \text{R})(1400 - 1049)\text{R} = 84.24 \text{ Btu/lbm} \end{aligned}$$

$$\begin{aligned} q_{\text{out},10-1} &= q_{\text{out},2-3} = c_p (T_{10} - T_1) \\ &= (0.240 \text{ Btu/lbm} \cdot \text{R})(737.8 - 520)\text{R} = 52.27 \text{ Btu/lbm} \end{aligned}$$

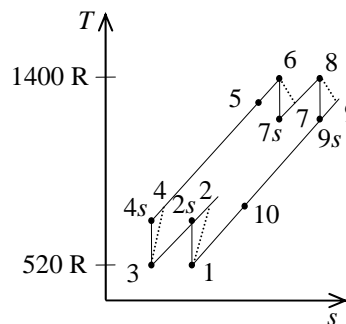

The exergy destruction during a process of a stream from an inlet state to exit state is given by

$$x_{\text{dest}} = T_0 s_{\text{gen}} = T_0 \left(s_e - s_i - \frac{q_{\text{in}}}{T_{\text{source}}} + \frac{q_{\text{out}}}{T_{\text{sink}}} \right)$$

Application of this equation for each process of the cycle gives

$$x_{\text{dest},1-2} = x_{\text{dest},3-4} = T_0 \left(c_p \ln \frac{T_2}{T_1} - R \ln \frac{P_2}{P_1} \right) = (520) \left[(0.24) \ln \frac{737.8}{520} - (0.06855) \ln(3) \right] = 4.50 \text{ Btu/lbm}$$

$$x_{\text{dest},5-6} = x_{\text{dest},7-8} = T_0 \left(c_p \ln \frac{T_6}{T_5} - R \ln \frac{P_6}{P_5} - \frac{q_{\text{in},5-6}}{T_{\text{source}}} \right) = (520) \left[(0.24) \ln \frac{1400}{1049} - 0 - \frac{84.24}{1400} \right] = 4.73 \text{ Btu/lbm}$$

$$x_{\text{dest},6-7} = x_{\text{dest},8-9} = T_0 \left(c_p \ln \frac{T_7}{T_6} - R \ln \frac{P_7}{P_6} \right) = (520) \left[(0.24) \ln \frac{1049}{1400} - (0.06855) \ln \left(\frac{1}{3} \right) \right] = 3.14 \text{ Btu/lbm}$$

$$x_{\text{dest},10-1} = x_{\text{dest},2-3} = T_0 \left(c_p \ln \frac{T_1}{T_{10}} - R \ln \frac{P_1}{P_{10}} + \frac{q_{\text{out}}}{T_{\text{sink}}} \right) = (520) \left[(0.24) \ln \frac{520}{737.8} - 0 + \frac{52.27}{520} \right] = 8.61 \text{ Btu/lbm}$$

$$\begin{aligned} x_{\text{dest,regen}} &= T_0 (\Delta s_{4-5} + \Delta s_{9-10}) = T_0 \left(c_p \ln \frac{T_5}{T_4} + c_p \ln \frac{T_{10}}{T_9} \right) \\ &= (520) \left[(0.24) \ln \frac{1049}{737.8} + (0.24) \ln \frac{737.8}{1049} \right] = 0 \text{ Btu/lbm} \end{aligned}$$

The greatest exergy destruction occurs during the heat rejection processes.

9-158 The exergy loss of each process for a regenerative Brayton cycle with three stages of reheating and intercooling described in Prob. 9-137 is to be determined.

Analysis From Prob. 9-137,

$$\begin{aligned} r_p &= 4, \quad q_{in,7-8} = q_{in,9-10} = q_{in,11-12} = 300 \text{ kJ/kg}, \\ q_{out,14-1} &= 181.8 \text{ kJ/kg}, \quad q_{out,2-3} = q_{out,4-5} = 141.6 \text{ kJ/kg}, \\ T_1 = T_3 = T_5 &= 290 \text{ K}, \quad T_2 = T_4 = T_6 = 430.9 \text{ K} \\ T_7 &= 556.7 \text{ K}, \quad T_8 = 855.2 \text{ K}, \quad T_9 = 575.5 \text{ K} \\ T_{10} &= 874.0 \text{ K}, \quad T_{11} = 588.2 \text{ K}, \quad T_{12} = 886.7 \text{ K}, \\ T_{13} &= 596.7 \text{ K}, \quad T_{14} = 470.9 \text{ K} \end{aligned}$$

The exergy destruction during a process of a stream from an inlet state to exit state is given by

$$x_{\text{dest}} = T_0 s_{\text{gen}} = T_0 \left(s_e - s_i - \frac{q_{in}}{T_{\text{source}}} + \frac{q_{out}}{T_{\text{sink}}} \right)$$

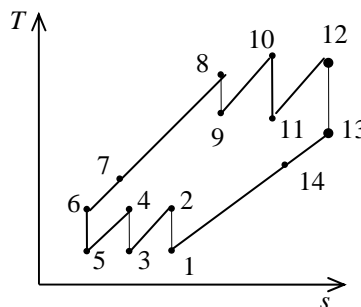

Application of this equation for each process of the cycle gives

$$\begin{aligned} x_{\text{dest},1-2} &= x_{\text{dest},3-4} = x_{\text{dest},5-6} = T_0 \left(c_p \ln \frac{T_2}{T_1} - R \ln \frac{P_2}{P_1} \right) \\ &= (290) \left[(1.005) \ln \frac{430.9}{290} - (0.287) \ln(4) \right] = \mathbf{0.03 \text{ kJ/kg} \approx 0} \end{aligned}$$

$$x_{\text{dest},7-8} = T_0 \left(c_p \ln \frac{T_8}{T_7} - R \ln \frac{P_8}{P_7} - \frac{q_{in,7-8}}{T_{\text{source}}} \right) = (290) \left[(1.005) \ln \frac{855.2}{556.7} - 0 - \frac{300}{886.7} \right] = \mathbf{27.0 \text{ kJ/kg}}$$

$$x_{\text{dest},9-10} = T_0 \left(c_p \ln \frac{T_{10}}{T_9} - R \ln \frac{P_{10}}{P_9} - \frac{q_{in,9-10}}{T_{\text{source}}} \right) = (290) \left[(1.005) \ln \frac{874.0}{575.5} - 0 - \frac{300}{886.7} \right] = \mathbf{23.7 \text{ kJ/kg}}$$

$$x_{\text{dest},11-12} = T_0 \left(c_p \ln \frac{T_{12}}{T_{11}} - R \ln \frac{P_{12}}{P_{11}} - \frac{q_{in,11-12}}{T_{\text{source}}} \right) = (290) \left[(1.005) \ln \frac{886.7}{588.2} - 0 - \frac{300}{886.7} \right] = \mathbf{21.5 \text{ kJ/kg}}$$

$$x_{\text{dest},8-9} = T_0 \left(c_p \ln \frac{T_9}{T_8} - R \ln \frac{P_9}{P_8} \right) = (290) \left[(1.005) \ln \frac{575.5}{855.2} - (0.287) \ln \left(\frac{1}{4} \right) \right] = \mathbf{-0.06 \text{ kJ/kg} \approx 0}$$

$$x_{\text{dest},10-11} = T_0 \left(c_p \ln \frac{T_{11}}{T_{10}} - R \ln \frac{P_{11}}{P_{10}} \right) = (290) \left[(1.005) \ln \frac{588.2}{874.0} - (0.287) \ln \left(\frac{1}{4} \right) \right] = \mathbf{0.42 \text{ kJ/kg} \approx 0}$$

$$x_{\text{dest},12-13} = T_0 \left(c_p \ln \frac{T_{13}}{T_{12}} - R \ln \frac{P_{13}}{P_{12}} \right) = (290) \left[(1.005) \ln \frac{596.7}{886.7} - (0.287) \ln \left(\frac{1}{4} \right) \right] = \mathbf{-0.05 \text{ kJ/kg} \approx 0}$$

$$x_{\text{dest},14-1} = T_0 \left(c_p \ln \frac{T_1}{T_{14}} - R \ln \frac{P_1}{P_{14}} + \frac{q_{out,14-1}}{T_{\text{sink}}} \right) = (290) \left[(1.005) \ln \frac{290}{470.9} - 0 + \frac{181.8}{290} \right] = \mathbf{40.5 \text{ kJ/kg}}$$

$$x_{\text{dest},2-3} = x_{\text{dest},4-5} = T_0 \left(c_p \ln \frac{T_3}{T_2} - R \ln \frac{P_3}{P_2} + \frac{q_{out,2-3}}{T_{\text{sink}}} \right) = (290) \left[(1.005) \ln \frac{290}{430.9} - 0 + \frac{141.6}{290} \right] = \mathbf{26.2 \text{ kJ/kg}}$$

$$\begin{aligned} x_{\text{dest,regen}} &= T_0 (\Delta s_{6-7} + \Delta s_{13-14}) = T_0 \left(c_p \ln \frac{T_7}{T_6} + c_p \ln \frac{T_{14}}{T_{13}} \right) \\ &= (290) \left[(1.005) \ln \frac{556.7}{430.9} + (1.005) \ln \frac{470.9}{596.7} \right] = \mathbf{5.65 \text{ kJ/kg}} \end{aligned}$$

9-159 A gas-turbine plant uses diesel fuel and operates on simple Brayton cycle. The isentropic efficiency of the compressor, the net power output, the back work ratio, the thermal efficiency, and the second-law efficiency are to be determined.

Assumptions 1 The air-standard assumptions are applicable. **2** Kinetic and potential energy changes are negligible. **3** Air is an ideal gas with constant specific heats.

Properties The properties of air at $500^\circ\text{C} = 773\text{ K}$ are $c_p = 1.093\text{ kJ/kg}\cdot\text{K}$, $c_v = 0.806\text{ kJ/kg}\cdot\text{K}$, $R = 0.287\text{ kJ/kg}\cdot\text{K}$, and $k = 1.357$ (Table A-2b).

Analysis (a) The isentropic efficiency of the compressor may be determined if we first calculate the exit temperature for the isentropic case

$$T_{2s} = T_1 \left(\frac{P_2}{P_1} \right)^{(k-1)/k} = (303\text{ K}) \left(\frac{700\text{ kPa}}{100\text{ kPa}} \right)^{(1.357-1)/1.357} = 505.6\text{ K}$$

$$\eta_C = \frac{T_{2s} - T_1}{T_2 - T_1} = \frac{(505.6 - 303)\text{ K}}{(533 - 303)\text{ K}} = \mathbf{0.881}$$

(b) The total mass flowing through the turbine and the rate of heat input are

$$\dot{m}_t = \dot{m}_a + \dot{m}_f = \dot{m}_a + \frac{\dot{m}_a}{\text{AF}} = 12.6\text{ kg/s} + \frac{12.6\text{ kg/s}}{60} = 12.6\text{ kg/s} + 0.21\text{ kg/s} = 12.81\text{ kg/s}$$

$$\dot{Q}_{\text{in}} = \dot{m}_f q_{\text{HV}} \eta_c = (0.21\text{ kg/s})(42,000\text{ kJ/kg})(0.97) = 8555\text{ kW}$$

The temperature at the exit of combustion chamber is

$$\dot{Q}_{\text{in}} = \dot{m} c_p (T_3 - T_2) \longrightarrow 8555\text{ kJ/s} = (12.81\text{ kg/s})(1.093\text{ kJ/kg}\cdot\text{K})(T_3 - 533)\text{ K} \longrightarrow T_3 = 1144\text{ K}$$

The temperature at the turbine exit is determined using isentropic efficiency relation

$$T_{4s} = T_3 \left(\frac{P_4}{P_3} \right)^{(k-1)/k} = (1144\text{ K}) \left(\frac{100\text{ kPa}}{700\text{ kPa}} \right)^{(1.357-1)/1.357} = 685.7\text{ K}$$

$$\eta_T = \frac{T_3 - T_4}{T_3 - T_{4s}} \longrightarrow 0.85 = \frac{(1144 - T_4)\text{ K}}{(1144 - 685.7)\text{ K}} \longrightarrow T_4 = 754.4\text{ K}$$

The net power and the back work ratio are

$$\dot{W}_{\text{C,in}} = \dot{m}_a c_p (T_2 - T_1) = (12.6\text{ kg/s})(1.093\text{ kJ/kg}\cdot\text{K})(533 - 303)\text{ K} = 3168\text{ kW}$$

$$\dot{W}_{\text{T,out}} = \dot{m} c_p (T_3 - T_4) = (12.81\text{ kg/s})(1.093\text{ kJ/kg}\cdot\text{K})(1144 - 754.4)\text{ K} = 5455\text{ kW}$$

$$\dot{W}_{\text{net}} = \dot{W}_{\text{T,out}} - \dot{W}_{\text{C,in}} = 5455 - 3168 = \mathbf{2287\text{ kW}}$$

$$r_{\text{bw}} = \frac{\dot{W}_{\text{C,in}}}{\dot{W}_{\text{T,out}}} = \frac{3168\text{ kW}}{5455\text{ kW}} = \mathbf{0.581}$$

(c) The thermal efficiency is $\eta_{\text{th}} = \frac{\dot{W}_{\text{net}}}{\dot{Q}_{\text{in}}} = \frac{2287\text{ kW}}{8555\text{ kW}} = \mathbf{0.267}$

The second-law efficiency of the cycle is defined as the ratio of actual thermal efficiency to the maximum possible thermal efficiency (Carnot efficiency). The maximum temperature for the cycle can be taken to be the turbine inlet temperature. That is,

$$\eta_{\text{max}} = 1 - \frac{T_1}{T_3} = 1 - \frac{303\text{ K}}{1144\text{ K}} = 0.735$$

and $\eta_{\text{II}} = \frac{\eta_{\text{th}}}{\eta_{\text{max}}} = \frac{0.267}{0.735} = \mathbf{0.364}$

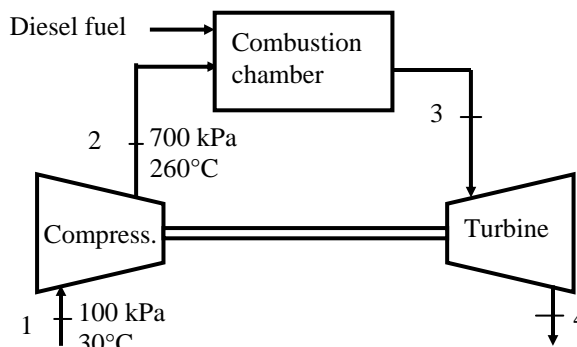

9-160 A modern compression ignition engine operates on the ideal dual cycle. The maximum temperature in the cycle, the net work output, the thermal efficiency, the mean effective pressure, the net power output, the second-law efficiency of the cycle, and the rate of exergy of the exhaust gases are to be determined.

Assumptions 1 The air-standard assumptions are applicable. **2** Kinetic and potential energy changes are negligible. **3** Air is an ideal gas with constant specific heats.

Properties The properties of air at 850 K are $c_p = 1.110$ kJ/kg·K, $c_v = 0.823$ kJ/kg·K, $R = 0.287$ kJ/kg·K, and $k = 1.349$ (Table A-2b).

Analysis (a) The clearance volume and the total volume of the engine at the beginning of compression process (state 1) are

$$r = \frac{V_c + V_d}{V_c} \longrightarrow 14 = \frac{V_c + 0.0028 \text{ m}^3}{V_c} \longrightarrow V_c = 0.0002154 \text{ m}^3 = V_2 = V_x$$

$$V_1 = V_c + V_d = 0.0002154 + 0.0028 = 0.003015 \text{ m}^3 = V_4$$

Process 1-2: Isentropic compression

$$T_2 = T_1 \left(\frac{V_1}{V_2} \right)^{k-1} = (328 \text{ K})(14)^{1.349-1} = 823.9 \text{ K}$$

$$P_2 = P_1 \left(\frac{V_1}{V_2} \right)^k = (95 \text{ kPa})(14)^{1.349} = 3341 \text{ kPa}$$

Process 2-x and x-3: Constant-volume and constant pressure heat addition processes:

$$T_x = T_2 \frac{P_x}{P_2} = (823.9 \text{ K}) \frac{9000 \text{ kPa}}{3341 \text{ kPa}} = 2220 \text{ K}$$

$$q_{2-x} = c_v (T_x - T_2) = (0.823 \text{ kJ/kg}\cdot\text{K})(2220 - 823.9) \text{ K} = 1149 \text{ kJ/kg}$$

$$q_{2-x} = q_{x-3} = c_p (T_3 - T_x) \longrightarrow 1149 \text{ kJ/kg} = (0.823 \text{ kJ/kg}\cdot\text{K})(T_3 - 2220) \text{ K} \longrightarrow T_3 = \mathbf{3254 \text{ K}}$$

(b) $q_{in} = q_{2-x} + q_{x-3} = 1149 + 1149 = 2298 \text{ kJ/kg}$

$$V_3 = V_x \frac{T_3}{T_x} = (0.0002154 \text{ m}^3) \frac{3254 \text{ K}}{2220 \text{ K}} = 0.0003158 \text{ m}^3$$

Process 3-4: isentropic expansion.

$$T_4 = T_3 \left(\frac{V_3}{V_4} \right)^{k-1} = (3254 \text{ K}) \left(\frac{0.0003158 \text{ m}^3}{0.003015 \text{ m}^3} \right)^{1.349-1} = 1481 \text{ K}$$

$$P_4 = P_3 \left(\frac{V_3}{V_4} \right)^k = (9000 \text{ kPa}) \left(\frac{0.0003158 \text{ m}^3}{0.003015 \text{ m}^3} \right)^{1.349} = 428.9 \text{ kPa}$$

Process 4-1: constant volume heat rejection.

$$q_{out} = c_v (T_4 - T_1) = (0.823 \text{ kJ/kg}\cdot\text{K})(1481 - 328) \text{ K} = 948.7 \text{ kJ/kg}$$

The net work output and the thermal efficiency are

$$w_{net,out} = q_{in} - q_{out} = 2298 - 948.7 = \mathbf{1349 \text{ kJ/kg}}$$

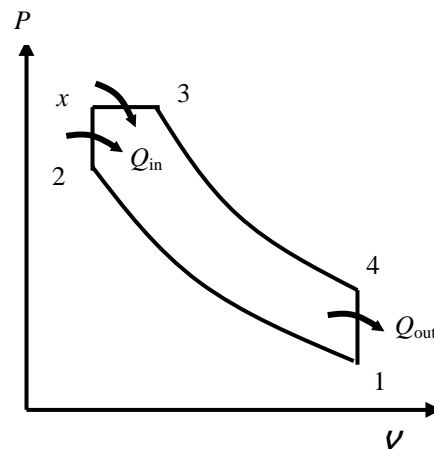

$$\eta_{\text{th}} = \frac{w_{\text{net,out}}}{q_{\text{in}}} = \frac{1349 \text{ kJ/kg}}{2298 \text{ kJ/kg}} = \mathbf{0.587}$$

(c) The mean effective pressure is determined to be

$$m = \frac{P_1 V_1}{RT_1} = \frac{(95 \text{ kPa})(0.003015 \text{ m}^3)}{(0.287 \text{ kPa} \cdot \text{m}^3/\text{kg} \cdot \text{K})(328 \text{ K})} = 0.003043 \text{ kg}$$

$$\text{MEP} = \frac{m w_{\text{net,out}}}{V_1 - V_2} = \frac{(0.003043 \text{ kg})(1349 \text{ kJ/kg})}{(0.003015 - 0.0002154) \text{ m}^3} \left(\frac{\text{kPa} \cdot \text{m}^3}{\text{kJ}} \right) = \mathbf{1466 \text{ kPa}}$$

(d) The power for engine speed of 3500 rpm is

$$\dot{W}_{\text{net}} = m w_{\text{net}} \frac{\dot{n}}{2} = (0.003043 \text{ kg})(1349 \text{ kJ/kg}) \frac{3500 \text{ (rev/min)}}{(2 \text{ rev/cycle})} \left(\frac{1 \text{ min}}{60 \text{ s}} \right) = \mathbf{120 \text{ kW}}$$

Note that there are two revolutions in one cycle in four-stroke engines.

(e) The second-law efficiency of the cycle is defined as the ratio of actual thermal efficiency to the maximum possible thermal efficiency (Carnot efficiency). We take the dead state temperature and pressure to be 25°C and 100 kPa.

$$\eta_{\text{max}} = 1 - \frac{T_0}{T_3} = 1 - \frac{(25 + 273) \text{ K}}{3254 \text{ K}} = 0.908$$

and

$$\eta_{\text{II}} = \frac{\eta_{\text{th}}}{\eta_{\text{max}}} = \frac{0.587}{0.908} = \mathbf{0.646}$$

The rate of exergy of the exhaust gases is determined as follows

$$x_4 = u_4 - u_0 - T_0(s_4 - s_0) = c_v(T_4 - T_0) - T_0 \left[c_p \ln \frac{T_4}{T_0} - R \ln \frac{P_4}{P_0} \right]$$

$$= (0.823)(1481 - 298) - (298) \left[(1.110 \text{ kJ/kg} \cdot \text{K}) \ln \frac{1481}{298} - 0.287 \ln \frac{428.9}{100} \right] = 567.6 \text{ kJ/kg}$$

$$\dot{X}_4 = m x_4 \frac{\dot{n}}{2} = (0.003043 \text{ kg})(567.6 \text{ kJ/kg}) \frac{3500 \text{ (rev/min)}}{(2 \text{ rev/cycle})} \left(\frac{1 \text{ min}}{60 \text{ s}} \right) = \mathbf{50.4 \text{ kW}}$$

Review Problems

9-161 A turbocharged four-stroke V-16 diesel engine produces 3500 hp at 1200 rpm. The amount of power produced per cylinder per mechanical and per thermodynamic cycle is to be determined.

Analysis Noting that there are 16 cylinders and each thermodynamic cycle corresponds to 2 mechanical cycles (revolutions), we have

(a)

$$\begin{aligned} w_{\text{mechanical}} &= \frac{\text{Total power produced}}{(\text{No. of cylinders})(\text{No. of mechanical cycles})} \\ &= \frac{3500 \text{ hp}}{(16 \text{ cylinders})(1200 \text{ rev/min})} \left(\frac{42.41 \text{ Btu/min}}{1 \text{ hp}} \right) \\ &= \mathbf{7.73 \text{ Btu/cyl} \cdot \text{mech cycle}} \quad (= 8.16 \text{ kJ/cyl} \cdot \text{mech cycle}) \end{aligned}$$

(b)

$$\begin{aligned} w_{\text{thermodynamic}} &= \frac{\text{Total power produced}}{(\text{No. of cylinders})(\text{No. of thermodynamic cycles})} \\ &= \frac{3500 \text{ hp}}{(16 \text{ cylinders})(1200/2 \text{ rev/min})} \left(\frac{42.41 \text{ Btu/min}}{1 \text{ hp}} \right) \\ &= \mathbf{15.46 \text{ Btu/cyl} \cdot \text{therm cycle}} \quad (= 16.31 \text{ kJ/cyl} \cdot \text{therm cycle}) \end{aligned}$$

9-162 A simple ideal Brayton cycle operating between the specified temperature limits is considered. The pressure ratio for which the compressor and the turbine exit temperature of air are equal is to be determined.

Assumptions **1** Steady operating conditions exist. **2** The air-standard assumptions are applicable. **3** Kinetic and potential energy changes are negligible. **4** Air is an ideal gas with constant specific heats.

Properties The specific heat ratio of air is $k = 1.4$ (Table A-2).

Analysis We treat air as an ideal gas with constant specific heats. Using the isentropic relations, the temperatures at the compressor and turbine exit can be expressed as

$$\begin{aligned} T_2 &= T_1 \left(\frac{P_2}{P_1} \right)^{(k-1)/k} = T_1 (r_p)^{(k-1)/k} \\ T_4 &= T_3 \left(\frac{P_4}{P_3} \right)^{(k-1)/k} = T_3 \left(\frac{1}{r_p} \right)^{(k-1)/k} \end{aligned}$$

Setting $T_2 = T_4$ and solving for r_p gives

$$r_p = \left(\frac{T_3}{T_1} \right)^{k/2(k-1)} = \left(\frac{1500 \text{ K}}{300 \text{ K}} \right)^{1.4/0.8} = \mathbf{16.7}$$

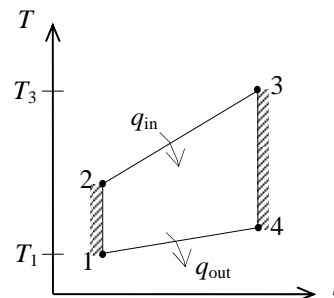

Therefore, the compressor and turbine exit temperatures will be equal when the compression ratio is 16.7.

9-163 The three processes of an air-standard cycle are described. The cycle is to be shown on P - v and T - s diagrams, and the maximum temperature in the cycle and the thermal efficiency are to be determined.

Assumptions 1 The air-standard assumptions are applicable. **2** Kinetic and potential energy changes are negligible. **3** Air is an ideal gas with variable specific heats.

Properties The properties of air are given in Table A-17.

Analysis (b) We treat air as an ideal gas with variable specific heats,

$$T_1 = 300 \text{ K} \longrightarrow u_1 = 214.07 \text{ kJ/kg}$$

$$P_{r_1} = 1.386$$

$$P_{r_2} = \frac{P_2}{P_1} P_{r_1} = \left(\frac{700 \text{ kPa}}{100 \text{ kPa}} \right) (1.386) = 9.702 \longrightarrow h_2 = 523.90 \text{ kJ/kg}$$

$$\frac{P_3 v_3}{T_3} = \frac{P_1 v_1}{T_1} \longrightarrow T_{\max} = T_3 = \frac{P_3}{P_1} T_1 = \left(\frac{700 \text{ kPa}}{100 \text{ kPa}} \right) (300 \text{ K}) = \mathbf{2100 \text{ K}}$$

$$T_3 = 2100 \text{ K} \longrightarrow u_3 = 1775.3 \text{ kJ/kg}$$

$$h_3 = 2377.7 \text{ kJ/kg}$$

$$(c) \quad q_{\text{in}} = h_3 - h_2 = 2377.7 - 523.9 = 1853.8 \text{ kJ/kg}$$

$$q_{\text{out}} = u_3 - u_1 = 1775.3 - 214.07 = 1561.23 \text{ kJ/kg}$$

$$\eta_{\text{th}} = 1 - \frac{q_{\text{out}}}{q_{\text{in}}} = 1 - \frac{1561.23 \text{ kJ/kg}}{1853.8 \text{ kJ/kg}} = \mathbf{15.8\%}$$

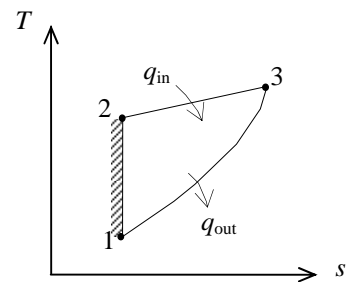
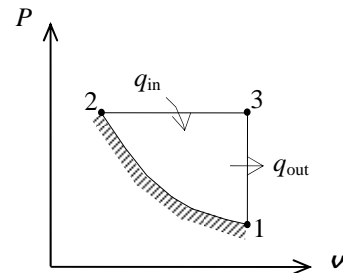

9-164 All three processes of an air-standard cycle are described. The cycle is to be shown on P - v and T - s diagrams, and the maximum temperature in the cycle and the thermal efficiency are to be determined.

Assumptions 1 The air-standard assumptions are applicable. **2** Kinetic and potential energy changes are negligible. **3** Air is an ideal gas with constant specific heats.

Properties The properties of air at room temperature are $c_p = 1.005 \text{ kJ/kg}\cdot\text{K}$, $c_v = 0.718 \text{ kJ/kg}\cdot\text{K}$, and $k = 1.4$ (Table A-2).

Analysis (b) We treat air as an ideal gas with constant specific heats.

Process 1-2 is isentropic:

$$T_2 = T_1 \left(\frac{P_2}{P_1} \right)^{(k-1)/k} = (300 \text{ K}) \left(\frac{700 \text{ kPa}}{100 \text{ kPa}} \right)^{0.4/1.4} = 523.1 \text{ K}$$

$$\frac{P_3 v_3}{T_3} = \frac{P_1 v_1}{T_1} \longrightarrow T_{\max} = T_3 = \frac{P_3}{P_1} T_1 = \left(\frac{700 \text{ kPa}}{100 \text{ kPa}} \right) (300 \text{ K}) = \mathbf{2100 \text{ K}}$$

$$(c) \quad q_{\text{in}} = h_3 - h_2 = c_p (T_3 - T_2) \\ = (1.005 \text{ kJ/kg}\cdot\text{K})(2100 - 523.1)\text{K} = 1584.8 \text{ kJ/kg}$$

$$q_{\text{out}} = u_3 - u_1 = c_v (T_3 - T_1) \\ = (0.718 \text{ kJ/kg}\cdot\text{K})(2100 - 300)\text{K} = 1292.4 \text{ kJ/kg}$$

$$\eta_{\text{th}} = 1 - \frac{q_{\text{out}}}{q_{\text{in}}} = 1 - \frac{1292.4 \text{ kJ/kg}}{1584.8 \text{ kJ/kg}} = \mathbf{18.5\%}$$

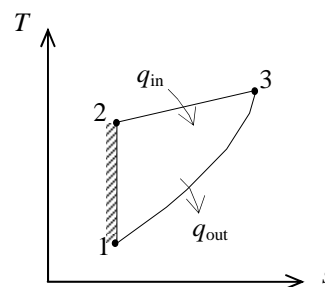
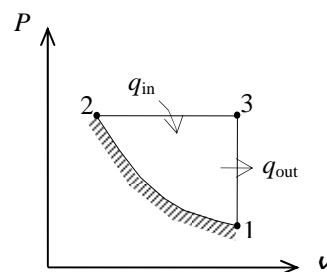

9-165 [Also solved by EES on enclosed CD] A four-cylinder spark-ignition engine with a compression ratio of 8 is considered. The amount of heat supplied per cylinder, the thermal efficiency, and the rpm for a net power output of 60 kW are to be determined.

Assumptions 1 The air-standard assumptions are applicable. **2** Kinetic and potential energy changes are negligible. **3** Air is an ideal gas with variable specific heats.

Properties The gas constant of air is $R = 0.287 \text{ kJ/kg}\cdot\text{K}$ (Table A-1). The properties of air are given in Table A-17.

Analysis (a) Process 1-2: isentropic compression.

$$T_1 = 290 \text{ K} \longrightarrow u_1 = 206.91 \text{ kJ/kg}$$

$$v_{r_1} = 676.1$$

$$v_{r_2} = \frac{v_2}{v_1} v_{r_1} = \frac{1}{r} v_{r_1} = \frac{1}{8} (676.1) = 84.51$$

$$\longrightarrow u_2 = 475.11 \text{ kJ/kg}$$

Process 2-3: $v = \text{constant}$ heat addition.

$$T_3 = 1800 \text{ K} \longrightarrow u_3 = 1487.2 \text{ kJ/kg}$$

$$v_{r_3} = 3.994$$

$$m = \frac{P_1 V_1}{RT_1} = \frac{(98 \text{ kPa})(0.0006 \text{ m}^3)}{(0.287 \text{ kPa}\cdot\text{m}^3/\text{kg}\cdot\text{K})(290 \text{ K})} = 7.065 \times 10^{-4} \text{ kg}$$

$$Q_{\text{in}} = m(u_3 - u_2) = (7.065 \times 10^{-4} \text{ kg})(1487.2 - 475.11) \text{ kJ/kg} = \mathbf{0.715 \text{ kJ}}$$

(b) Process 3-4: isentropic expansion.

$$v_{r_4} = \frac{v_4}{v_3} v_{r_3} = r v_{r_3} = (8)(3.994) = 31.95 \longrightarrow u_4 = 693.23 \text{ kJ/kg}$$

Process 4-1: $v = \text{constant}$ heat rejection.

$$Q_{\text{out}} = m(u_4 - u_1) = (7.065 \times 10^{-4} \text{ kg})(693.23 - 206.91) \text{ kJ/kg} = \mathbf{0.344 \text{ kJ}}$$

$$W_{\text{net}} = Q_{\text{in}} - Q_{\text{out}} = 0.715 - 0.344 = 0.371 \text{ kJ}$$

$$\eta_{\text{th}} = \frac{W_{\text{net}}}{Q_{\text{in}}} = \frac{0.371 \text{ kJ}}{0.715 \text{ kJ}} = \mathbf{51.9\%}$$

$$(c) \quad \dot{n} = 2 \frac{\dot{W}_{\text{net}}}{n_{\text{cyl}} W_{\text{net,cyl}}} = (2 \text{ rev/cycle}) \frac{60 \text{ kJ/s}}{4 \times (0.371 \text{ kJ/cycle})} \left(\frac{60 \text{ s}}{1 \text{ min}} \right) = \mathbf{4852 \text{ rpm}}$$

Note that for four-stroke cycles, there are two revolutions per cycle.

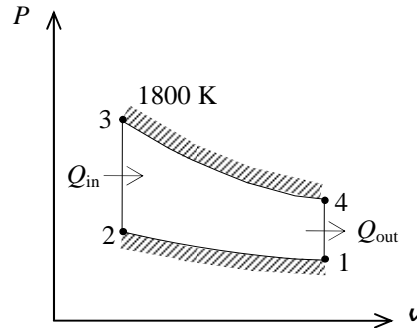

9-166 EES Problem 9-165 is reconsidered. The effect of the compression ratio net work done and the efficiency of the cycle is to be investigated. Also, the T - s and P - v diagrams for the cycle are to be plotted.

Analysis Using EES, the problem is solved as follows:

"Input Data"

$$T[1]=(17+273) \text{ [K]}$$

$$P[1]=98 \text{ [kPa]}$$

$$T[3]=1800 \text{ [K]}$$

$$V_{\text{cyl}}=0.6 \text{ [L]} * \text{Convert(L, m}^3\text{)}$$

$$r_v=8 \text{ "Compression ratio"}$$

$$W_{\text{dot_net}} = 60 \text{ [kW]}$$

$$N_{\text{cyl}}=4 \text{ "number of cylinders"}$$

$$v[1]/v[2]=r_v$$

"The first part of the solution is done per unit mass."

"Process 1-2 is isentropic compression"

$$s[1]=\text{entropy}(\text{air}, T=T[1], P=P[1])$$

$$s[2]=s[1]$$

$$s[2]=\text{entropy}(\text{air}, T=T[2], v=v[2])$$

$$P[2]*v[2]/T[2]=P[1]*v[1]/T[1]$$

$$P[1]*v[1]=R*T[1]$$

$$R=0.287 \text{ [kJ/kg-K]}$$

"Conservation of energy for process 1 to 2: no heat transfer ($s=\text{const.}$) with work input"

$$w_{\text{in}} = \text{DELTAu}_{12}$$

$$\text{DELTAu}_{12}=\text{intenergy}(\text{air}, T=T[2])-\text{intenergy}(\text{air}, T=T[1])$$

"Process 2-3 is constant volume heat addition"

$$s[3]=\text{entropy}(\text{air}, T=T[3], P=P[3])$$

$$\{P[3]*v[3]/T[3]=P[2]*v[2]/T[2]\}$$

$$P[3]*v[3]=R*T[3]$$

$$v[3]=v[2]$$

"Conservation of energy for process 2 to 3: the work is zero for $v=\text{const}$, heat is added"

$$q_{\text{in}} = \text{DELTAu}_{23}$$

$$\text{DELTAu}_{23}=\text{intenergy}(\text{air}, T=T[3])-\text{intenergy}(\text{air}, T=T[2])$$

"Process 3-4 is isentropic expansion"

$$s[4]=\text{entropy}(\text{air}, T=T[4], P=P[4])$$

$$s[4]=s[3]$$

$$P[4]*v[4]/T[4]=P[3]*v[3]/T[3]$$

$$\{P[4]*v[4]=R*T[4]\}$$

"Conservation of energy for process 3 to 4: no heat transfer ($s=\text{const}$) with work output"

$$-w_{\text{out}} = \text{DELTAu}_{34}$$

$$\text{DELTAu}_{34}=\text{intenergy}(\text{air}, T=T[4])-\text{intenergy}(\text{air}, T=T[3])$$

"Process 4-1 is constant volume heat rejection"

$$v[4]=v[1]$$

"Conservation of energy for process 4 to 1: the work is zero for $v=\text{const}$; heat is rejected"

$$-q_{\text{out}} = \text{DELTAu}_{41}$$

$$\text{DELTAu}_{41}=\text{intenergy}(\text{air}, T=T[1])-\text{intenergy}(\text{air}, T=T[4])$$

$$w_{\text{net}} = w_{\text{out}} - w_{\text{in}}$$

$$\text{Eta}_{\text{th}}=w_{\text{net}}/q_{\text{in}} * \text{Convert}(, \%) \text{ "Thermal efficiency, in percent"}$$

"The mass contained in each cylinder is found from the volume of the cylinder:"

$$V_{\text{cyl}}=m*v[1]$$

"The net work done per cycle is:"

$$W_{\text{dot_net}}=m*w_{\text{net}} \text{ "kJ/cyl"} * N_{\text{cyl}} * N_{\text{dot}} \text{ "mechanical cycles/min"} * 1 \text{ "min"} / 60 \text{ "s"} * 1 \text{ "thermal cycle"} / 2 \text{ "mechanical cycles"}$$

η_{th} [%]	r_v	W_{net} [kJ/kg]
42.81	5	467.1
46.39	6	492.5
49.26	7	509.8
51.63	8	521.7
53.63	9	529.8
55.35	10	535.2
56.85	11	538.5

Air Otto Cycle P-v Diagram

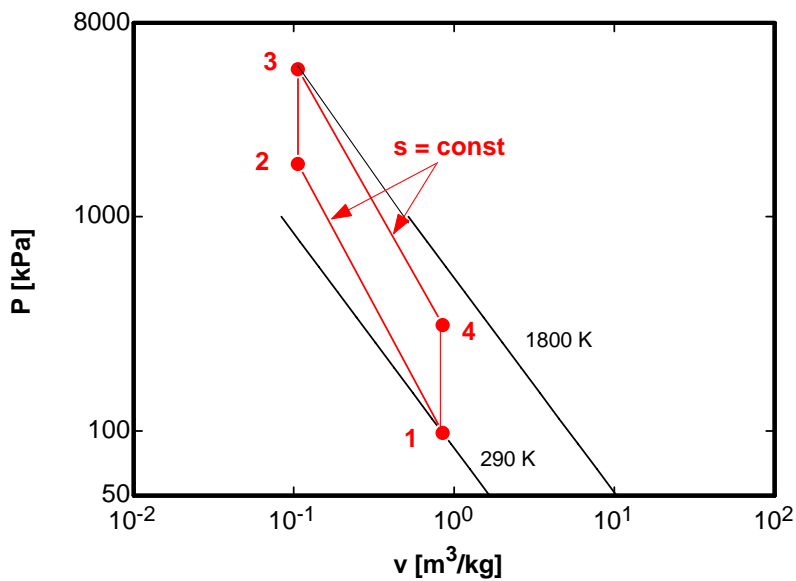

Air Otto Cycle T-s Diagram

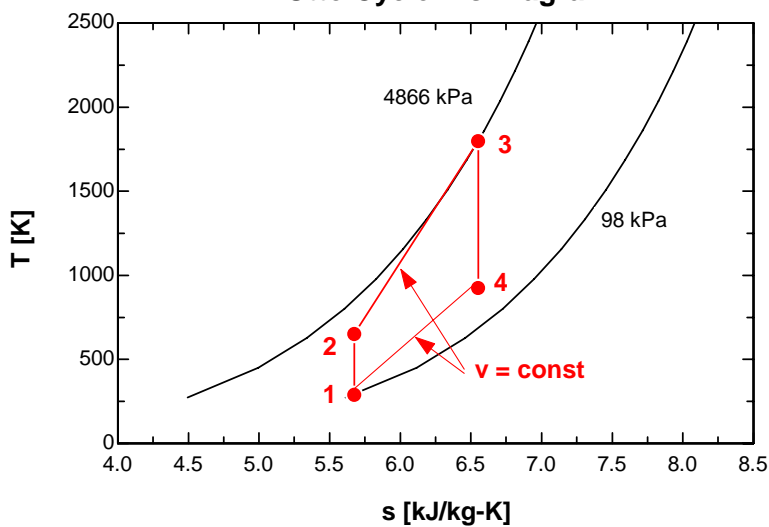

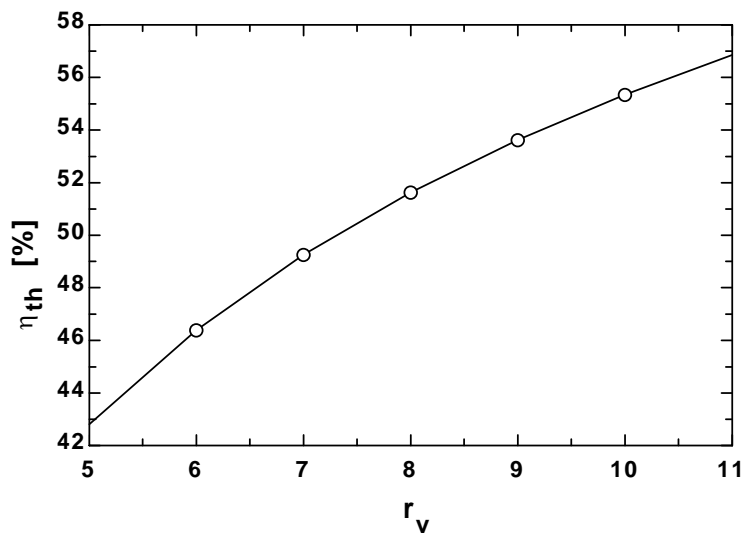
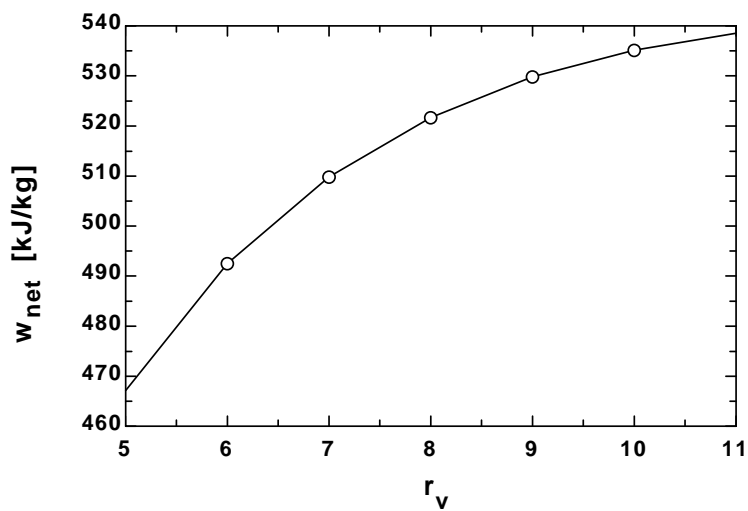

9-167 An ideal gas Carnot cycle with helium as the working fluid is considered. The pressure ratio, compression ratio, and minimum temperature of the energy source are to be determined.

Assumptions 1 Kinetic and potential energy changes are negligible. **2** Helium is an ideal gas with constant specific heats.

Properties The specific heat ratio of helium is $k = 1.667$ (Table A-2a).

Analysis From the definition of the thermal efficiency of a Carnot heat engine,

$$\eta_{\text{th,Carnot}} = 1 - \frac{T_L}{T_H} \longrightarrow T_H = \frac{T_L}{1 - \eta_{\text{th,Carnot}}} = \frac{(15 + 273) \text{ K}}{1 - 0.50} = \mathbf{576 \text{ K}}$$

An isentropic process for an ideal gas is one in which $P\dot{v}$ remains constant. Then, the pressure ratio is

$$\frac{P_2}{P_1} = \left(\frac{T_2}{T_1} \right)^{k/(k-1)} = \left(\frac{576 \text{ K}}{288 \text{ K}} \right)^{1.667/(1.667-1)} = \mathbf{5.65}$$

Based on the process equation, the compression ratio is

$$\frac{v_1}{v_2} = \left(\frac{P_2}{P_1} \right)^{1/k} = (5.65)^{1/1.667} = \mathbf{2.83}$$

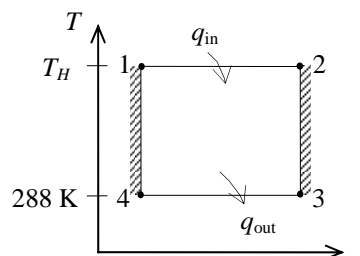

9-168E An ideal gas Carnot cycle with helium as the working fluid is considered. The pressure ratio, compression ratio, and minimum temperature of the energy-source reservoir are to be determined.

Assumptions 1 Kinetic and potential energy changes are negligible. **2** Helium is an ideal gas with constant specific heats.

Properties The specific heat ratio of helium is $k = 1.667$ (Table A-2Ea).

Analysis From the definition of the thermal efficiency of a Carnot heat engine,

$$\eta_{\text{th,Carnot}} = 1 - \frac{T_L}{T_H} \longrightarrow T_H = \frac{T_L}{1 - \eta_{\text{th,Carnot}}} = \frac{(60 + 460) \text{ R}}{1 - 0.60} = \mathbf{1300 \text{ R}}$$

An isentropic process for an ideal gas is one in which $P\dot{v}$ remains constant. Then, the pressure ratio is

$$\frac{P_2}{P_1} = \left(\frac{T_2}{T_1} \right)^{k/(k-1)} = \left(\frac{1300 \text{ R}}{520 \text{ R}} \right)^{1.667/(1.667-1)} = \mathbf{9.88}$$

Based on the process equation, the compression ratio is

$$\frac{v_1}{v_2} = \left(\frac{P_2}{P_1} \right)^{1/k} = (9.88)^{1/1.667} = \mathbf{3.95}$$

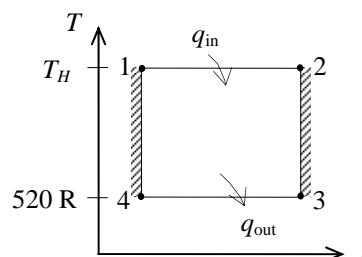

9-169 The compression ratio required for an ideal Otto cycle to produce certain amount of work when consuming a given amount of fuel is to be determined.

Assumptions 1 The air-standard assumptions are applicable. **2** Kinetic and potential energy changes are negligible. **3** Air is an ideal gas with constant specific heats. **4** The combustion efficiency is 100 percent.

Properties The properties of air at room temperature are $c_p = 1.005 \text{ kJ/kg}\cdot\text{K}$, $c_v = 0.718 \text{ kJ/kg}\cdot\text{K}$, and $k = 1.4$ (Table A-2).

Analysis The heat input to the cycle for 0.043 grams of fuel consumption is

$$Q_{\text{in}} = m_{\text{fuel}} q_{\text{HV}} = (0.043 \times 10^{-3} \text{ kg})(42,000 \text{ kJ/kg}) = 1.806 \text{ kJ}$$

The thermal efficiency is then

$$\eta_{\text{th}} = \frac{W_{\text{net}}}{Q_{\text{in}}} = \frac{1 \text{ kJ}}{1.806 \text{ kJ}} = 0.5537$$

From the definition of thermal efficiency, we obtain the required compression ratio to be

$$\eta_{\text{th}} = 1 - \frac{1}{r^{k-1}} \longrightarrow r = \frac{1}{(1 - \eta_{\text{th}})^{1/(k-1)}} = \frac{1}{(1 - 0.5537)^{1/(1.4-1)}} = \mathbf{7.52}$$

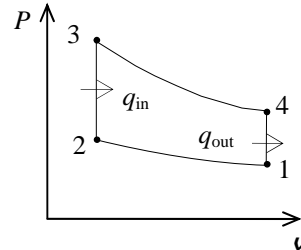

9-170 An equation is to be developed for $q_{\text{in}} / (c_v T_1 r^{k-1})$ in terms of k , r_c and r_p .

Assumptions 1 The air-standard assumptions are applicable. **2** Kinetic and potential energy changes are negligible. **3** Air is an ideal gas with constant specific heats.

Analysis The temperatures at various points of the dual cycle are given by

$$T_2 = T_1 r^{k-1}$$

$$T_x = T_2 \left(\frac{P_x}{P_2} \right) = T_2 r_p = r_p T_1 r^{k-1}$$

$$T_3 = T_x \left(\frac{v_3}{v_x} \right) = T_x r_c = r_p r_c T_1 r^{k-1}$$

Application of the first law to the two heat addition processes gives

$$\begin{aligned} q_{\text{in}} &= c_v (T_x - T_2) + c_p (T_3 - T_x) \\ &= c_v (r_p T_1 r^{k-1} - T_1 r^{k-1}) + c_p (r_p r_c T_1 r^{k-1} - r_p T_1 r^{k-1}) \end{aligned}$$

or upon rearrangement

$$\frac{q_{\text{in}}}{c_v T_1 r^{k-1}} = (r_p - 1) + k r_p (r_c - 1)$$

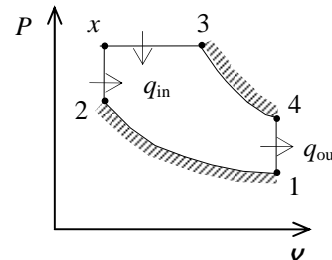

9-171 An ideal Otto cycle with air as the working fluid with a compression ratio of 9.2 is considered. The amount of heat transferred to the air, the net work output, the thermal efficiency, and the mean effective pressure are to be determined.

Assumptions 1 The air-standard assumptions are applicable. **2** Kinetic and potential energy changes are negligible. **3** Air is an ideal gas with variable specific heats.

Properties The gas constant of air is $R = 0.287 \text{ kJ/kg}\cdot\text{K}$ (Table A-1). The properties of air are given in Table A-17.

Analysis (a) Process 1-2: isentropic compression.

$$T_1 = 300 \text{ K} \longrightarrow u_1 = 214.07 \text{ kJ/kg}$$

$$v_{r_1} = 621.2$$

$$v_{r_2} = \frac{v_2}{v_1} v_{r_1} = \frac{1}{r} v_{r_1} = \frac{1}{9.2} (621.2) = 67.52 \longrightarrow T_2 = 708.3 \text{ K}$$

$$u_2 = 518.9 \text{ kJ/kg}$$

$$\frac{P_2 v_2}{T_2} = \frac{P_1 v_1}{T_1} \longrightarrow P_2 = \frac{v_1}{v_2} \frac{T_2}{T_1} P_1 = (9.2) \left(\frac{708.3 \text{ K}}{300 \text{ K}} \right) (98 \text{ kPa}) = 2129 \text{ kPa}$$

Process 2-3: $v = \text{constant}$ heat addition.

$$\frac{P_3 v_3}{T_3} = \frac{P_2 v_2}{T_2} \longrightarrow T_3 = \frac{P_3}{P_2} T_2 = 2T_2 = (2)(708.3) = 1416.6 \text{ K} \longrightarrow u_3 = 1128.7 \text{ kJ/kg}$$

$$v_{r_3} = 8.593$$

$$q_{in} = u_3 - u_2 = 1128.7 - 518.9 = \mathbf{609.8 \text{ kJ/kg}}$$

(b) Process 3-4: isentropic expansion.

$$v_{r_4} = \frac{v_4}{v_3} v_{r_3} = r v_{r_3} = (9.2)(8.593) = 79.06 \longrightarrow u_4 = 487.75 \text{ kJ/kg}$$

Process 4-1: $v = \text{constant}$ heat rejection.

$$q_{out} = u_4 - u_1 = 487.75 - 214.07 = 273.7 \text{ kJ/kg}$$

$$w_{net} = q_{in} - q_{out} = 609.8 - 273.7 = \mathbf{336.1 \text{ kJ/kg}}$$

$$(c) \quad \eta_{th} = \frac{w_{net}}{q_{in}} = \frac{336.1 \text{ kJ/kg}}{609.8 \text{ kJ/kg}} = \mathbf{55.1\%}$$

$$(d) \quad v_{max} = v_1 = \frac{RT_1}{P_1} = \frac{(0.287 \text{ kPa}\cdot\text{m}^3/\text{kg}\cdot\text{K})(300 \text{ K})}{98 \text{ kPa}} = 0.879 \text{ m}^3/\text{kg}$$

$$v_{min} = v_2 = \frac{v_{max}}{r}$$

$$MEP = \frac{w_{net}}{v_1 - v_2} = \frac{w_{net}}{v_1(1 - 1/r)} = \frac{336.1 \text{ kJ/kg}}{(0.879 \text{ m}^3/\text{kg})(1 - 1/9.2)} \left(\frac{1 \text{ kPa}\cdot\text{m}^3}{1 \text{ kJ}} \right) = \mathbf{429 \text{ kPa}}$$

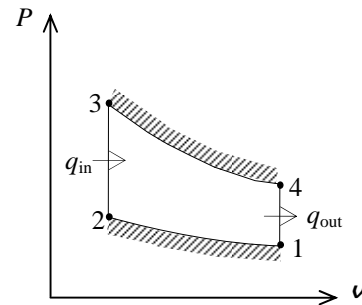

9-172 An ideal Otto cycle with air as the working fluid with a compression ratio of 9.2 is considered. The amount of heat transferred to the air, the net work output, the thermal efficiency, and the mean effective pressure are to be determined.

Assumptions 1 The air-standard assumptions are applicable. **2** Kinetic and potential energy changes are negligible. **3** Air is an ideal gas with constant specific heats.

Properties The properties of air at room temperature are $c_p = 1.005 \text{ kJ/kg}\cdot\text{K}$, $c_v = 0.718 \text{ kJ/kg}\cdot\text{K}$, and $k = 1.4$ (Table A-2).

Analysis (a) Process 1-2 is isentropic compression:

$$T_2 = T_1 \left(\frac{v_1}{v_2} \right)^{k-1} = (300 \text{ K})(9.2)^{0.4} = 728.8 \text{ K}$$

$$\frac{P_2 v_2}{T_2} = \frac{P_1 v_1}{T_1} \longrightarrow P_2 = \frac{v_1}{v_2} \frac{T_2}{T_1} P_1 = (9.2) \left(\frac{728.8 \text{ K}}{300 \text{ K}} \right) (98 \text{ kPa}) = 2190 \text{ kPa}$$

Process 2-3: $v = \text{constant}$ heat addition.

$$\frac{P_3 v_3}{T_3} = \frac{P_2 v_2}{T_2} \longrightarrow T_3 = \frac{P_3}{P_2} T_2 = 2T_2 = (2)(728.8) = 1457.6 \text{ K}$$

$$q_{\text{in}} = u_3 - u_2 = c_v (T_3 - T_2) = (0.718 \text{ kJ/kg}\cdot\text{K})(1457.6 - 728.8) \text{ K} = 523.3 \text{ kJ/kg}$$

(b) Process 3-4: isentropic expansion.

$$T_4 = T_3 \left(\frac{v_3}{v_4} \right)^{k-1} = (1457.6 \text{ K}) \left(\frac{1}{9.2} \right)^{0.4} = 600.0 \text{ K}$$

Process 4-1: $v = \text{constant}$ heat rejection.

$$q_{\text{out}} = u_4 - u_1 = c_v (T_4 - T_1) = (0.718 \text{ kJ/kg}\cdot\text{K})(600 - 300) \text{ K} = 215.4 \text{ kJ/kg}$$

$$w_{\text{net}} = q_{\text{in}} - q_{\text{out}} = 523.3 - 215.4 = 307.9 \text{ kJ/kg}$$

$$(c) \quad \eta_{\text{th}} = \frac{w_{\text{net}}}{q_{\text{in}}} = \frac{307.9 \text{ kJ/kg}}{523.3 \text{ kJ/kg}} = 58.8\%$$

$$(d) \quad v_{\text{max}} = v_1 = \frac{RT_1}{P_1} = \frac{(0.287 \text{ kPa}\cdot\text{m}^3/\text{kg}\cdot\text{K})(300 \text{ K})}{98 \text{ kPa}} = 0.879 \text{ m}^3/\text{kg}$$

$$v_{\text{min}} = v_2 = \frac{v_{\text{max}}}{r}$$

$$\text{MEP} = \frac{w_{\text{net}}}{v_1 - v_2} = \frac{w_{\text{net}}}{v_1 (1 - 1/r)} = \frac{307.9 \text{ kJ/kg}}{(0.879 \text{ m}^3/\text{kg})(1 - 1/9.2)} \left(\frac{1 \text{ kPa}\cdot\text{m}^3}{1 \text{ kJ}} \right) = 393 \text{ kPa}$$

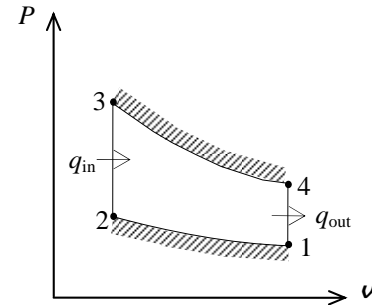

9-173 An engine operating on the ideal diesel cycle with air as the working fluid is considered. The pressure at the beginning of the heat-rejection process, the net work per cycle, and the mean effective pressure are to be determined.

Assumptions 1 The air-standard assumptions are applicable. 2 Kinetic and potential energy changes are negligible. 3 Air is an ideal gas with variable specific heats.

Properties The gas constant of air is $R = 0.287 \text{ kJ/kg}\cdot\text{K}$ (Table A-1). The properties of air are given in Table A-17.

Analysis (a) The compression and the cutoff ratios are

$$r = \frac{V_1}{V_2} = \frac{1200 \text{ cm}^3}{75 \text{ cm}^3} = 16 \quad r_c = \frac{V_3}{V_2} = \frac{150 \text{ cm}^3}{75 \text{ cm}^3} = 2$$

Process 1-2: isentropic compression.

$$T_1 = 290 \text{ K} \longrightarrow u_1 = 206.91 \text{ kJ/kg} \\ \nu_{r_1} = 676.1$$

$$\nu_{r_2} = \frac{\nu_2}{\nu_1} \nu_{r_1} = \frac{1}{r} \nu_{r_1} = \frac{1}{16} (676.1) = 42.256 \longrightarrow T_2 = 837.3 \text{ K} \\ h_2 = 863.03 \text{ kJ/kg}$$

Process 2-3: $P = \text{constant}$ heat addition.

$$\frac{P_3 \nu_3}{T_3} = \frac{P_2 \nu_2}{T_2} \longrightarrow T_3 = \frac{\nu_3}{\nu_2} T_2 = 2T_2 = (2)(837.3) = 1674.6 \text{ K} \\ \longrightarrow h_3 = 1848.9 \text{ kJ/kg} \\ \nu_{r_3} = 5.002$$

Process 3-4: isentropic expansion.

$$\nu_{r_4} = \frac{\nu_4}{\nu_3} \nu_{r_3} = \frac{\nu_4}{2\nu_2} \nu_{r_3} = \frac{r}{2} \nu_{r_3} = \left(\frac{16}{2}\right)(5.002) = 40.016 \longrightarrow T_4 = 853.4 \text{ K} \\ u_4 = 636.00 \text{ kJ/kg}$$

Process 4-1: $\nu = \text{constant}$ heat rejection.

$$\frac{P_4 \nu_4}{T_4} = \frac{P_1 \nu_1}{T_1} \longrightarrow P_4 = \frac{T_4}{T_1} P_1 = \left(\frac{853.4 \text{ K}}{290 \text{ K}}\right)(100 \text{ kPa}) = \mathbf{294.3 \text{ kPa}}$$

$$(b) \quad m = \frac{P_1 V_1}{RT_1} = \frac{(100 \text{ kPa})(0.0012 \text{ m}^3)}{(0.287 \text{ kPa}\cdot\text{m}^3/\text{kg}\cdot\text{K})(290 \text{ K})} = 1.442 \times 10^{-3} \text{ kg}$$

$$Q_{\text{in}} = m(h_3 - h_2) = (1.442 \times 10^{-3} \text{ kg})(1848.9 - 863.08) = 1.422 \text{ kJ}$$

$$Q_{\text{out}} = m(u_4 - u_1) = (1.442 \times 10^{-3} \text{ kg})(636.00 - 206.91) \text{ kJ/kg} = 0.619 \text{ kJ}$$

$$W_{\text{net}} = Q_{\text{in}} - Q_{\text{out}} = 1.422 - 0.619 = \mathbf{0.803 \text{ kJ}}$$

$$(c) \quad \text{MEP} = \frac{W_{\text{net}}}{V_1 - V_2} = \frac{W_{\text{net}}}{V_1(1 - 1/r)} = \frac{0.803 \text{ kJ}}{(0.0012 \text{ m}^3)(1 - 1/16)} \left(\frac{1 \text{ kPa}\cdot\text{m}^3}{1 \text{ kJ}}\right) = \mathbf{714 \text{ kPa}}$$

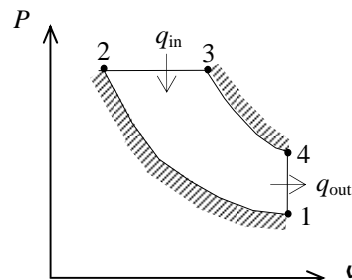

9-174 An engine operating on the ideal diesel cycle with argon as the working fluid is considered. The pressure at the beginning of the heat-rejection process, the net work per cycle, and the mean effective pressure are to be determined.

Assumptions 1 The air-standard assumptions are applicable. 2 Kinetic and potential energy changes are negligible. 3 Argon is an ideal gas with constant specific heats.

Properties The properties of argon at room temperature are $c_p = 0.5203$ kJ/kg·K, $c_v = 0.3122$ kJ/kg·K, $R = 0.2081$ kJ/kg·K and $k = 1.667$ (Table A-2).

Analysis (a) The compression and the cutoff ratios are

$$r = \frac{V_1}{V_2} = \frac{1200 \text{ cm}^3}{75 \text{ cm}^3} = 16 \quad r_c = \frac{V_3}{V_2} = \frac{150 \text{ cm}^3}{75 \text{ cm}^3} = 2$$

Process 1-2: isentropic compression.

$$T_2 = T_1 \left(\frac{V_2}{V_1} \right)^{k-1} = (290 \text{ K})(16)^{0.667} = 1843 \text{ K}$$

Process 2-3: $P = \text{constant}$ heat addition.

$$\frac{P_3 V_3}{T_3} = \frac{P_2 V_2}{T_2} \longrightarrow T_3 = \frac{V_3}{V_2} T_2 = 2T_2 = (2)(1843) = 3686 \text{ K}$$

Process 3-4: isentropic expansion.

$$T_4 = T_3 \left(\frac{V_3}{V_4} \right)^{k-1} = T_3 \left(\frac{2V_2}{V_4} \right)^{k-1} = T_3 \left(\frac{2}{r} \right)^{k-1} = (3686 \text{ K}) \left(\frac{2}{16} \right)^{0.667} = 920.9 \text{ K}$$

Process 4-1: $v = \text{constant}$ heat rejection.

$$\frac{P_4 V_4}{T_4} = \frac{P_1 V_1}{T_1} \longrightarrow P_4 = \frac{T_4}{T_1} P_1 = \left(\frac{920.9 \text{ K}}{290 \text{ K}} \right) (100 \text{ kPa}) = \mathbf{317.6 \text{ kPa}}$$

$$(b) \quad m = \frac{P_1 V_1}{RT_1} = \frac{(100 \text{ kPa})(0.0012 \text{ m}^3)}{(0.2081 \text{ kPa} \cdot \text{m}^3/\text{kg} \cdot \text{K})(290 \text{ K})} = 1.988 \times 10^{-3} \text{ kg}$$

$$Q_{\text{in}} = m(h_3 - h_2) = mc_p(T_3 - T_2) = (1.988 \times 10^{-3} \text{ kg})(0.5203 \text{ kJ/kg} \cdot \text{K})(3686 - 1843) \text{ K} = 1.906 \text{ kJ}$$

$$Q_{\text{out}} = m(u_4 - u_1) = mc_v(T_4 - T_1) = (1.988 \times 10^{-3} \text{ kg})(0.3122 \text{ kJ/kg} \cdot \text{K})(920.9 - 290) \text{ K} = 0.392 \text{ kJ}$$

$$W_{\text{net}} = Q_{\text{in}} - Q_{\text{out}} = 1.906 - 0.392 = \mathbf{1.514 \text{ kJ}}$$

$$(c) \quad \text{MEP} = \frac{W_{\text{net}}}{V_1 - V_2} = \frac{W_{\text{net}}}{V_1(1 - 1/r)} = \frac{1.514 \text{ kJ}}{(0.0012 \text{ m}^3)(1 - 1/16)} \left(\frac{1 \text{ kPa} \cdot \text{m}^3}{1 \text{ kJ}} \right) = \mathbf{1346 \text{ kPa}}$$

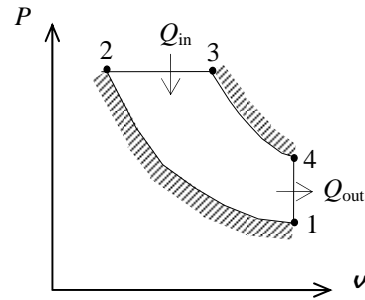

9-175E An ideal dual cycle with air as the working fluid with a compression ratio of 12 is considered. The thermal efficiency of the cycle is to be determined.

Assumptions 1 The air-standard assumptions are applicable. **2** Kinetic and potential energy changes are negligible. **3** Air is an ideal gas with constant specific heats.

Properties The properties of air at room temperature are $c_p = 0.240$ Btu/lbm·R, $c_v = 0.171$ Btu/lbm·R, and $k = 1.4$ (Table A-2E).

Analysis The mass of air is

$$m = \frac{P_1 V_1}{RT_1} = \frac{(14.7 \text{ psia})(75/1728 \text{ ft}^3)}{(0.3704 \text{ psia} \cdot \text{ft}^3/\text{lbm} \cdot \text{R})(550 \text{ R})} = 3.132 \times 10^{-3} \text{ lbm}$$

Process 1-2: isentropic compression.

$$T_2 = T_1 \left(\frac{V_1}{V_2} \right)^{k-1} = (550 \text{ R})(12)^{0.4} = 1486 \text{ R}$$

Process 2-x: $v = \text{constant}$ heat addition,

$$\begin{aligned} Q_{2-x,\text{in}} &= m(u_x - u_2) = mc_v(T_x - T_2) \\ 0.3 \text{ Btu} &= (3.132 \times 10^{-3} \text{ lbm})(0.171 \text{ Btu/lbm} \cdot \text{R})(T_x - 1486) \text{ R} \longrightarrow T_x = 2046 \text{ R} \end{aligned}$$

Process x-3: $P = \text{constant}$ heat addition.

$$\begin{aligned} Q_{x-3,\text{in}} &= m(h_3 - h_x) = mc_p(T_3 - T_x) \\ 1.1 \text{ Btu} &= (3.132 \times 10^{-3} \text{ lbm})(0.240 \text{ Btu/lbm} \cdot \text{R})(T_3 - 2046) \text{ R} \longrightarrow T_3 = 3509 \text{ R} \end{aligned}$$

$$\frac{P_3 V_3}{T_3} = \frac{P_x V_x}{T_x} \longrightarrow r_c = \frac{V_3}{V_x} = \frac{T_3}{T_x} = \frac{3509 \text{ R}}{2046 \text{ R}} = 1.715$$

Process 3-4: isentropic expansion.

$$T_4 = T_3 \left(\frac{V_3}{V_4} \right)^{k-1} = T_3 \left(\frac{1.715 V_1}{V_4} \right)^{k-1} = T_3 \left(\frac{1.715}{r} \right)^{k-1} = (3509 \text{ R}) \left(\frac{1.715}{12} \right)^{0.4} = 1611 \text{ R}$$

Process 4-1: $v = \text{constant}$ heat rejection.

$$\begin{aligned} Q_{\text{out}} &= m(u_4 - u_1) = mc_v(T_4 - T_1) \\ &= (3.132 \times 10^{-3} \text{ lbm})(0.171 \text{ Btu/lbm} \cdot \text{R})(1611 - 550) \text{ R} = 0.568 \text{ Btu} \end{aligned}$$

$$\eta_{\text{th}} = 1 - \frac{Q_{\text{out}}}{Q_{\text{in}}} = 1 - \frac{0.568 \text{ Btu}}{1.4 \text{ Btu}} = \mathbf{59.4\%}$$

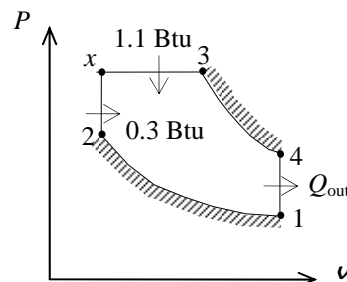

9-176 An ideal Stirling cycle with air as the working fluid is considered. The maximum pressure in the cycle and the net work output are to be determined.

Assumptions 1 The air-standard assumptions are applicable. **2** Kinetic and potential energy changes are negligible. **3** Air is an ideal gas with constant specific heats.

Properties The properties of air at room temperature are $R = 0.287 \text{ kJ/kg}\cdot\text{K}$, $c_p = 1.005 \text{ kJ/kg}\cdot\text{K}$, $c_v = 0.718 \text{ kJ/kg}\cdot\text{K}$, and $k = 1.4$ (Table A-2).

Analysis (a) The entropy change during process 1-2 is

$$s_2 - s_1 = \frac{q_{12}}{T_H} = \frac{900 \text{ kJ/kg}}{1800 \text{ K}} = 0.5 \text{ kJ/kg}\cdot\text{K}$$

and

$$s_2 - s_1 = c_v \ln \frac{T_2}{T_1} + R \ln \frac{v_2}{v_1} \longrightarrow 0.5 \text{ kJ/kg}\cdot\text{K} = (0.287 \text{ kJ/kg}\cdot\text{K}) \ln \frac{v_2}{v_1} \longrightarrow \frac{v_2}{v_1} = 5.710$$

$$\frac{P_3 v_3}{T_3} = \frac{P_1 v_1}{T_1} \longrightarrow P_1 = P_3 \frac{v_3}{v_1} \frac{T_1}{T_3} = P_3 \frac{v_2}{v_1} \frac{T_1}{T_3} = (200 \text{ kPa}) (5.710) \left(\frac{1800 \text{ K}}{350 \text{ K}} \right) = \mathbf{5873 \text{ kPa}}$$

$$(b) \quad w_{\text{net}} = \eta_{\text{th}} q_{\text{in}} = \left(1 - \frac{T_L}{T_H} \right) q_{\text{in}} = \left(1 - \frac{350 \text{ K}}{1800 \text{ K}} \right) (900 \text{ kJ/kg}) = \mathbf{725 \text{ kJ/kg}}$$

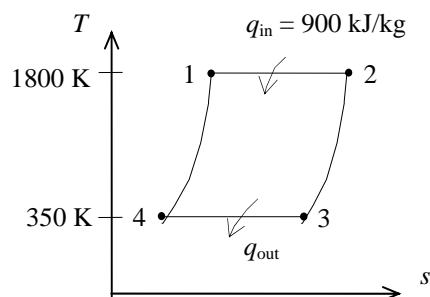

9-177 A simple ideal Brayton cycle with air as the working fluid is considered. The changes in the net work output per unit mass and the thermal efficiency are to be determined.

Assumptions 1 The air-standard assumptions are applicable. **2** Kinetic and potential energy changes are negligible. **3** Air is an ideal gas with variable specific heats.

Properties The properties of air are given in Table A-17.

Analysis The properties at various states are

$$T_1 = 300 \text{ K} \longrightarrow h_1 = 300.19 \text{ kJ/kg}$$

$$P_{r_1} = 1.386$$

$$T_3 = 1300 \text{ K} \longrightarrow h_3 = 1395.97 \text{ kJ/kg}$$

$$P_{r_3} = 330.9$$

For $r_p = 6$,

$$P_{r_2} = \frac{P_2}{P_1} P_{r_1} = (6)(1.386) = 8.316 \longrightarrow h_2 = 501.40 \text{ kJ/kg}$$

$$P_{r_4} = \frac{P_4}{P_3} P_{r_3} = \left(\frac{1}{6}\right)(330.9) = 55.15 \longrightarrow h_4 = 855.3 \text{ kJ/kg}$$

$$q_{\text{in}} = h_3 - h_2 = 1395.97 - 501.40 = 894.57 \text{ kJ/kg}$$

$$q_{\text{out}} = h_4 - h_1 = 855.3 - 300.19 = 555.11 \text{ kJ/kg}$$

$$w_{\text{net}} = q_{\text{in}} - q_{\text{out}} = 894.57 - 555.11 = 339.46 \text{ kJ/kg}$$

$$\eta_{\text{th}} = \frac{w_{\text{net}}}{q_{\text{in}}} = \frac{339.46 \text{ kJ/kg}}{894.57 \text{ kJ/kg}} = 37.9\%$$

For $r_p = 12$,

$$P_{r_2} = \frac{P_2}{P_1} P_{r_1} = (12)(1.386) = 16.63 \longrightarrow h_2 = 610.6 \text{ kJ/kg}$$

$$P_{r_4} = \frac{P_4}{P_3} P_{r_3} = \left(\frac{1}{12}\right)(330.9) = 27.58 \longrightarrow h_4 = 704.6 \text{ kJ/kg}$$

$$q_{\text{in}} = h_3 - h_2 = 1395.97 - 610.60 = 785.37 \text{ kJ/kg}$$

$$q_{\text{out}} = h_4 - h_1 = 704.6 - 300.19 = 404.41 \text{ kJ/kg}$$

$$w_{\text{net}} = q_{\text{in}} - q_{\text{out}} = 785.37 - 404.41 = 380.96 \text{ kJ/kg}$$

$$\eta_{\text{th}} = \frac{w_{\text{net}}}{q_{\text{in}}} = \frac{380.96 \text{ kJ/kg}}{785.37 \text{ kJ/kg}} = 48.5\%$$

Thus,

(a) $\Delta w_{\text{net}} = 380.96 - 339.46 = \mathbf{41.5 \text{ kJ/kg}}$ (increase)

(b) $\Delta \eta_{\text{th}} = 48.5\% - 37.9\% = \mathbf{10.6\%}$ (increase)

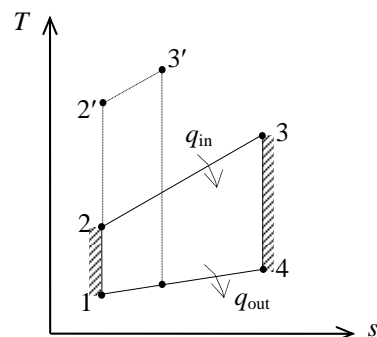

9-178 A simple ideal Brayton cycle with air as the working fluid is considered. The changes in the net work output per unit mass and the thermal efficiency are to be determined.

Assumptions 1 The air-standard assumptions are applicable. **2** Kinetic and potential energy changes are negligible. **3** Air is an ideal gas with constant specific heats.

Properties The properties of air at room temperature are $R = 0.287 \text{ kJ/kg}\cdot\text{K}$, $c_p = 1.005 \text{ kJ/kg}\cdot\text{K}$, $c_v = 0.718 \text{ kJ/kg}\cdot\text{K}$, and $k = 1.4$ (Table A-2).

Analysis Processes 1-2 and 3-4 are isentropic. Therefore, For $r_p = 6$,

$$T_2 = T_1 \left(\frac{P_2}{P_1} \right)^{(k-1)/k} = (300 \text{ K})(6)^{0.4/1.4} = 500.6 \text{ K}$$

$$T_4 = T_3 \left(\frac{P_4}{P_3} \right)^{(k-1)/k} = (1300 \text{ K}) \left(\frac{1}{6} \right)^{0.4/1.4} = 779.1 \text{ K}$$

$$q_{\text{in}} = h_3 - h_2 = c_p (T_3 - T_2) \\ = (1.005 \text{ kJ/kg}\cdot\text{K})(1300 - 500.6)\text{K} = 803.4 \text{ kJ/kg}$$

$$q_{\text{out}} = h_4 - h_1 = c_p (T_4 - T_1) \\ = (1.005 \text{ kJ/kg}\cdot\text{K})(779.1 - 300)\text{K} = 481.5 \text{ kJ/kg}$$

$$w_{\text{net}} = q_{\text{in}} - q_{\text{out}} = 803.4 - 481.5 = 321.9 \text{ kJ/kg}$$

$$\eta_{\text{th}} = \frac{w_{\text{net}}}{q_{\text{in}}} = \frac{321.9 \text{ kJ/kg}}{803.4 \text{ kJ/kg}} = 40.1\%$$

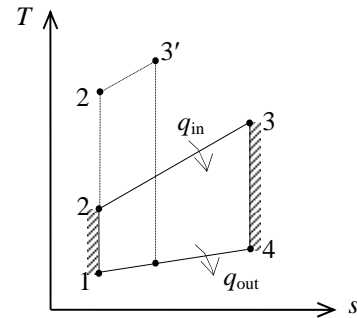

For $r_p = 12$,

$$T_2 = T_1 \left(\frac{P_2}{P_1} \right)^{(k-1)/k} = (300 \text{ K})(12)^{0.4/1.4} = 610.2 \text{ K}$$

$$T_4 = T_3 \left(\frac{P_4}{P_3} \right)^{(k-1)/k} = (1300 \text{ K}) \left(\frac{1}{12} \right)^{0.4/1.4} = 639.2 \text{ K}$$

$$q_{\text{in}} = h_3 - h_2 = c_p (T_3 - T_2) \\ = (1.005 \text{ kJ/kg}\cdot\text{K})(1300 - 610.2)\text{K} = 693.2 \text{ kJ/kg}$$

$$q_{\text{out}} = h_4 - h_1 = c_p (T_4 - T_1) \\ = (1.005 \text{ kJ/kg}\cdot\text{K})(639.2 - 300)\text{K} = 340.9 \text{ kJ/kg}$$

$$w_{\text{net}} = q_{\text{in}} - q_{\text{out}} = 693.2 - 340.9 = 352.3 \text{ kJ/kg}$$

$$\eta_{\text{th}} = \frac{w_{\text{net}}}{q_{\text{in}}} = \frac{352.3 \text{ kJ/kg}}{693.2 \text{ kJ/kg}} = 50.8\%$$

Thus,

$$(a) \quad \Delta w_{\text{net}} = 352.3 - 321.9 = \mathbf{30.4 \text{ kJ/kg}} \quad (\text{increase})$$

$$(b) \quad \Delta \eta_{\text{th}} = 50.8\% - 40.1\% = \mathbf{10.7\%} \quad (\text{increase})$$

9-179 A regenerative gas-turbine engine operating with two stages of compression and two stages of expansion is considered. The back work ratio and the thermal efficiency are to be determined.

Assumptions 1 The air-standard assumptions are applicable.

2 Kinetic and potential energy changes are negligible. **3** Air is an ideal gas with constant specific heats.

Properties The properties of air at room temperature are $c_p = 1.005 \text{ kJ/kg}\cdot\text{K}$, $c_v = 0.718 \text{ kJ/kg}\cdot\text{K}$, and $k = 1.4$ (Table A-2).

Analysis The work inputs to each stage of compressor are identical, so are the work outputs of each stage of the turbine.

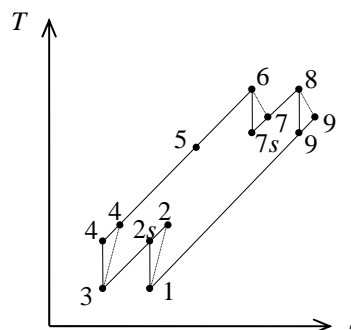

$$T_{4s} = T_{2s} = T_1 \left(\frac{P_2}{P_1} \right)^{(k-1)/k} = (300 \text{ K})(3.5)^{0.4/1.4} = 429.1 \text{ K}$$

$$\eta_C = \frac{h_{2s} - h_1}{h_2 - h_1} = \frac{c_p(T_{2s} - T_1)}{c_p(T_2 - T_1)} \longrightarrow T_4 = T_2 = T_1 + (T_{2s} - T_1)/\eta_C$$

$$= 300 + (429.1 - 300)/(0.78)$$

$$= 465.5 \text{ K}$$

$$T_{9s} = T_{7s} = T_6 \left(\frac{P_7}{P_6} \right)^{(k-1)/k} = (1200 \text{ K}) \left(\frac{1}{3.5} \right)^{0.4/1.4} = 838.9 \text{ K}$$

$$\eta_T = \frac{h_6 - h_7}{h_6 - h_{7s}} = \frac{c_p(T_6 - T_7)}{c_p(T_6 - T_{7s})} \longrightarrow T_9 = T_7 = T_6 - \eta_T(T_6 - T_{7s})$$

$$= 1200 - (0.86)(1200 - 838.9)$$

$$= 889.5 \text{ K}$$

$$\varepsilon = \frac{h_5 - h_4}{h_9 - h_4} = \frac{c_p(T_5 - T_4)}{c_p(T_9 - T_4)} \longrightarrow T_5 = T_4 + \varepsilon(T_9 - T_4)$$

$$= 465.5 + (0.72)(889.5 - 465.5)$$

$$= 770.8 \text{ K}$$

$$w_{C,\text{in}} = 2(h_2 - h_1) = 2c_p(T_2 - T_1) = 2(1.005 \text{ kJ/kg}\cdot\text{K})(465.5 - 300)\text{K} = 332.7 \text{ kJ/kg}$$

$$w_{T,\text{out}} = 2(h_6 - h_7) = 2c_p(T_6 - T_7) = 2(1.005 \text{ kJ/kg}\cdot\text{K})(1200 - 889.5)\text{K} = 624.1 \text{ kJ/kg}$$

Thus,

$$r_{\text{bw}} = \frac{w_{C,\text{in}}}{w_{T,\text{out}}} = \frac{332.7 \text{ kJ/kg}}{624.1 \text{ kJ/kg}} = \mathbf{53.3\%}$$

$$q_{\text{in}} = (h_6 - h_5) + (h_8 - h_7) = c_p [(T_6 - T_5) + (T_8 - T_7)]$$

$$= (1.005 \text{ kJ/kg}\cdot\text{K}) [(1200 - 770.8) + (1200 - 889.5)]\text{K} = 743.4 \text{ kJ/kg}$$

$$w_{\text{net}} = w_{T,\text{out}} - w_{C,\text{in}} = 624.1 - 332.7 = 291.4 \text{ kJ/kg}$$

$$\eta_{\text{th}} = \frac{w_{\text{net}}}{q_{\text{in}}} = \frac{291.4 \text{ kJ/kg}}{743.4 \text{ kJ/kg}} = \mathbf{39.2\%}$$

9-180 EES Problem 9-179 is reconsidered. The effect of the isentropic efficiencies for the compressor and turbine and regenerator effectiveness on net work done and the heat supplied to the cycle is to be investigated. Also, the T - s diagram for the cycle is to be plotted.

Analysis Using EES, the problem is solved as follows:

"Input data"

$$T[6] = 1200 \text{ [K]}$$

$$T[8] = T[6]$$

$$\text{Pratio} = 3.5$$

$$T[1] = 300 \text{ [K]}$$

$$P[1] = 100 \text{ [kPa]}$$

$$T[3] = T[1]$$

$$\text{Eta_reg} = 0.72 \text{ "Regenerator effectiveness"}$$

$$\text{Eta_c} = 0.78 \text{ "Compressor isentropic efficiency"}$$

$$\text{Eta_t} = 0.86 \text{ "Turbine isentropic efficiency"}$$

"LP Compressor:"

"Isentropic Compressor analysis"

$$s[1] = \text{ENTROPY}(\text{Air}, T=T[1], P=P[1])$$

$$s_s[2] = s[1] \text{ "For the ideal case the entropies are constant across the compressor"}$$

$$P[2] = \text{Pratio} * P[1]$$

$$s_s[2] = \text{ENTROPY}(\text{Air}, T=T_s[2], P=P[2])$$

$$T_s[2] \text{ is the isentropic value of } T[2] \text{ at compressor exit"}$$

$$\text{Eta_c} = w_compisen_LP / w_comp_LP$$

$$\text{"compressor adiabatic efficiency, } W_comp > W_compisen"$$

"Conservation of energy for the LP compressor for the isentropic case:

$$e_in - e_out = \Delta e = 0 \text{ for steady-flow"}$$

$$h[1] + w_compisen_LP = h_s[2]$$

$$h[1] = \text{ENTHALPY}(\text{Air}, T=T[1])$$

$$h_s[2] = \text{ENTHALPY}(\text{Air}, T=T_s[2])$$

"Actual compressor analysis:"

$$h[1] + w_comp_LP = h[2]$$

$$h[2] = \text{ENTHALPY}(\text{Air}, T=T[2])$$

$$s[2] = \text{ENTROPY}(\text{Air}, T=T[2], P=P[2])$$

"HP Compressor:"

$$s[3] = \text{ENTROPY}(\text{Air}, T=T[3], P=P[3])$$

$$s_s[4] = s[3] \text{ "For the ideal case the entropies are constant across the HP compressor"}$$

$$P[4] = \text{Pratio} * P[3]$$

$$P[3] = P[2]$$

$$s_s[4] = \text{ENTROPY}(\text{Air}, T=T_s[4], P=P[4])$$

$$T_s[4] \text{ is the isentropic value of } T[4] \text{ at compressor exit"}$$

$$\text{Eta_c} = w_compisen_HP / w_comp_HP$$

$$\text{"compressor adiabatic efficiency, } W_comp > W_compisen"$$

"Conservation of energy for the compressor for the isentropic case:

$$e_in - e_out = \Delta e = 0 \text{ for steady-flow"}$$

$$h[3] + w_compisen_HP = h_s[4]$$

$$h[3] = \text{ENTHALPY}(\text{Air}, T=T[3])$$

$$h_s[4] = \text{ENTHALPY}(\text{Air}, T=T_s[4])$$

"Actual compressor analysis:"

$$h[3] + w_comp_HP = h[4]$$

h[4]=ENTHALPY(Air,T=T[4])
s[4]=ENTROPY(Air,T=T[4], P=P[4])

"Intercooling heat loss:"

h[2] = q_out_intercool + h[3]

"External heat exchanger analysis"

"SSSF First Law for the heat exchanger, assuming W=0, ke=pe=0

e_in - e_out = DELTAe_cv = 0 for steady flow"

h[4] + q_in_noreg = h[6]

h[6]=ENTHALPY(Air,T=T[6])

P[6]=P[4]"process 4-6 is SSSF constant pressure"

"HP Turbine analysis"

s[6]=ENTROPY(Air,T=T[6],P=P[6])

s_s[7]=s[6] "For the ideal case the entropies are constant across the turbine"

P[7] = P[6] /Pratio

s_s[7]=ENTROPY(Air,T=T_s[7],P=P[7])"T_s[7] is the isentropic value of T[7] at HP turbine exit"

Eta_t = w_turb_HP /w_turbisen_HP "turbine adiabatic efficiency, w_turbisen > w_turb"

"SSSF First Law for the isentropic turbine, assuming: adiabatic, ke=pe=0

e_in -e_out = DELTAe_cv = 0 for steady-flow"

h[6] = w_turbisen_HP + h_s[7]

h_s[7]=ENTHALPY(Air,T=T_s[7])

"Actual Turbine analysis:"

h[6] = w_turb_HP + h[7]

h[7]=ENTHALPY(Air,T=T[7])

s[7]=ENTROPY(Air,T=T[7], P=P[7])

"Reheat Q_in:"

h[7] + q_in_reheat = h[8]

h[8]=ENTHALPY(Air,T=T[8])

"HL Turbine analysis"

P[8]=P[7]

s[8]=ENTROPY(Air,T=T[8],P=P[8])

s_s[9]=s[8] "For the ideal case the entropies are constant across the turbine"

P[9] = P[8] /Pratio

s_s[9]=ENTROPY(Air,T=T_s[9],P=P[9])"T_s[9] is the isentropic value of T[9] at LP turbine exit"

Eta_t = w_turb_LP /w_turbisen_LP "turbine adiabatic efficiency, w_turbisen > w_turb"

"SSSF First Law for the isentropic turbine, assuming: adiabatic, ke=pe=0

e_in -e_out = DELTAe_cv = 0 for steady-flow"

h[8] = w_turbisen_LP + h_s[9]

h_s[9]=ENTHALPY(Air,T=T_s[9])

"Actual Turbine analysis:"

h[8] = w_turb_LP + h[9]

h[9]=ENTHALPY(Air,T=T[9])

s[9]=ENTROPY(Air,T=T[9], P=P[9])

"Cycle analysis"

w_net=w_turb_HP+w_turb_LP - w_comp_HP - w_comp_LP

q_in_total_noreg=q_in_noreg+q_in_reheat

Eta_th_noreg=w_net/(q_in_total_noreg)*Convert(, %) "[%]" "Cycle thermal efficiency"

$Bwr = (w_{comp_HP} + w_{comp_LP}) / (w_{turb_HP} + w_{turb_LP})$ "Back work ratio"

"With the regenerator, the heat added in the external heat exchanger is"

$h[5] + q_{in_withreg} = h[6]$
 $h[5] = ENTHALPY(Air, T=T[5])$
 $s[5] = ENTROPY(Air, T=T[5], P=P[5])$
 $P[5] = P[4]$

"The regenerator effectiveness gives $h[5]$ and thus $T[5]$ as:"

$\eta_{reg} = (h[5] - h[4]) / (h[9] - h[4])$

"Energy balance on regenerator gives $h[10]$ and thus $T[10]$ as:"

$h[4] + h[9] = h[5] + h[10]$
 $h[10] = ENTHALPY(Air, T=T[10])$
 $s[10] = ENTROPY(Air, T=T[10], P=P[10])$
 $P[10] = P[9]$

"Cycle thermal efficiency with regenerator"

$q_{in_total_withreg} = q_{in_withreg} + q_{in_reheat}$
 $\eta_{th_withreg} = w_{net} / (q_{in_total_withreg}) * Convert(, \%) "[\%]"$

"The following data is used to complete the Array Table for plotting purposes."

$s_s[1] = s[1]$
 $T_s[1] = T[1]$
 $s_s[3] = s[3]$
 $T_s[3] = T[3]$
 $s_s[5] = ENTROPY(Air, T=T[5], P=P[5])$
 $T_s[5] = T[5]$
 $s_s[6] = s[6]$
 $T_s[6] = T[6]$
 $s_s[8] = s[8]$
 $T_s[8] = T[8]$
 $s_s[10] = s[10]$
 $T_s[10] = T[10]$

η_c	η_{reg}	η_t	$\eta_{th, noreg}$ [%]	$\eta_{th, withreg}$ [%]	$q_{in, total, noreg}$ [kJ/kg]	$q_{in, total, withreg}$ [kJ/kg]	W_{net} [kJ/kg]
0.78	0.6	0.86	27.03	36.59	1130	834.6	305.4
0.78	0.65	0.86	27.03	37.7	1130	810	305.4
0.78	0.7	0.86	27.03	38.88	1130	785.4	305.4
0.78	0.75	0.86	27.03	40.14	1130	760.8	305.4
0.78	0.8	0.86	27.03	41.48	1130	736.2	305.4
0.78	0.85	0.86	27.03	42.92	1130	711.6	305.4
0.78	0.9	0.86	27.03	44.45	1130	687	305.4
0.78	0.95	0.86	27.03	46.11	1130	662.4	305.4
0.78	1	0.86	27.03	47.88	1130	637.8	305.4

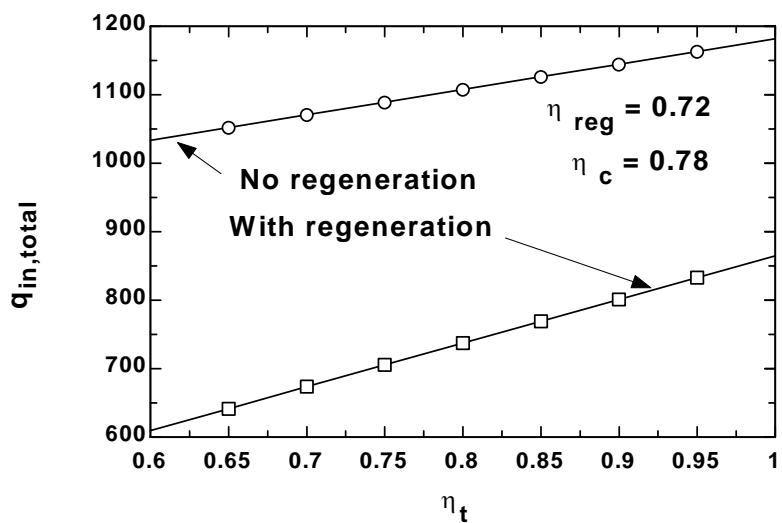
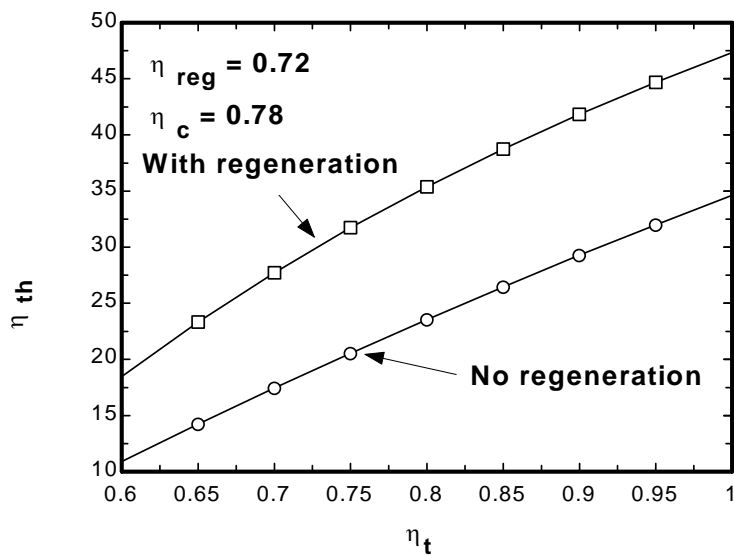
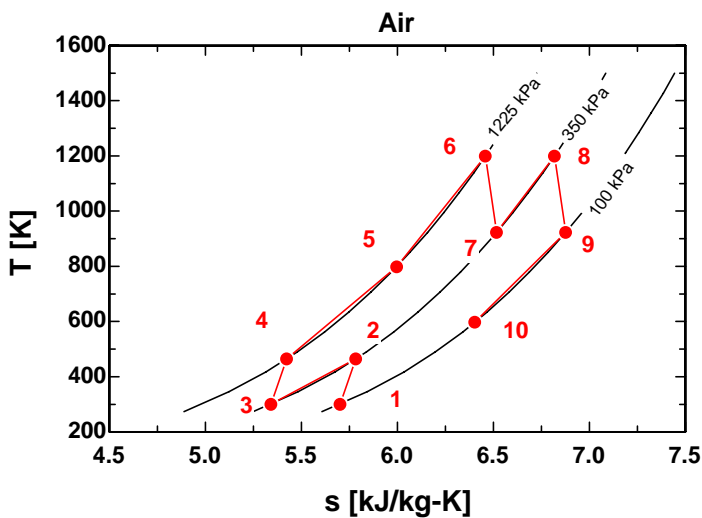

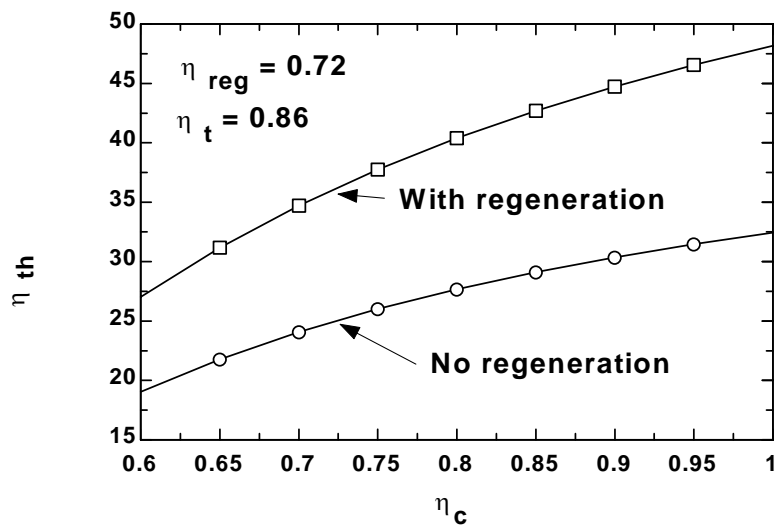
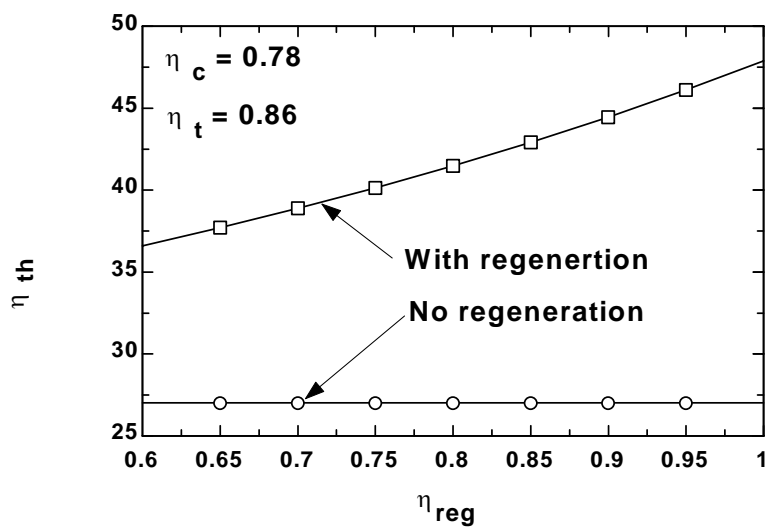
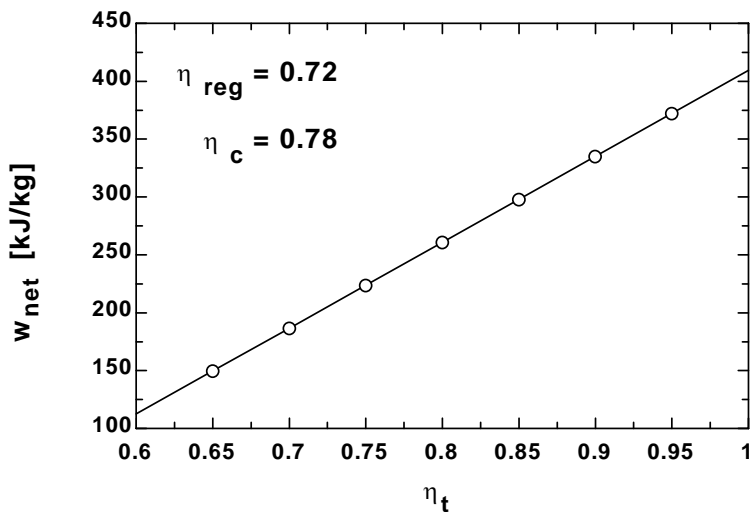

9-181 A regenerative gas-turbine engine operating with two stages of compression and two stages of expansion is considered. The back work ratio and the thermal efficiency are to be determined.

Assumptions 1 The air-standard assumptions are applicable. **2** Kinetic and potential energy changes are negligible. **3** Helium is an ideal gas with constant specific heats.

Properties The properties of helium at room temperature are $c_p = 5.1926 \text{ kJ/kg}\cdot\text{K}$ and $k = 1.667$ (Table A-2).

Analysis The work inputs to each stage of compressor are identical, so are the work outputs of each stage of the turbine.

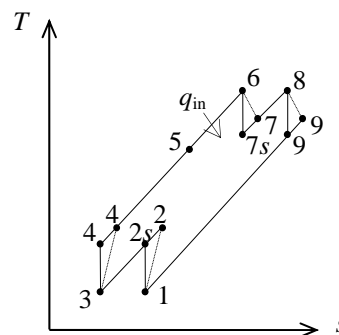

$$T_{4s} = T_{2s} = T_1 \left(\frac{P_2}{P_1} \right)^{(k-1)/k} = (300 \text{ K})(3.5)^{0.667/1.667} = 495.2 \text{ K}$$

$$\eta_C = \frac{h_{2s} - h_1}{h_2 - h_1} = \frac{c_p(T_{2s} - T_1)}{c_p(T_2 - T_1)} \longrightarrow T_4 = T_2 = T_1 + (T_{2s} - T_1)/\eta_C$$

$$= 300 + (495.2 - 300)/(0.78)$$

$$= 550.3 \text{ K}$$

$$T_{9s} = T_{7s} = T_6 \left(\frac{P_7}{P_6} \right)^{(k-1)/k} = (1200 \text{ K}) \left(\frac{1}{3.5} \right)^{0.667/1.667} = 726.9 \text{ K}$$

$$\eta_T = \frac{h_6 - h_7}{h_6 - h_{7s}} = \frac{c_p(T_6 - T_7)}{c_p(T_6 - T_{7s})} \longrightarrow T_9 = T_7 = T_6 - \eta_T(T_6 - T_{7s})$$

$$= 1200 - (0.86)(1200 - 726.9)$$

$$= 793.1 \text{ K}$$

$$\varepsilon = \frac{h_5 - h_4}{h_9 - h_4} = \frac{c_p(T_5 - T_4)}{c_p(T_9 - T_4)} \longrightarrow T_5 = T_4 + \varepsilon(T_9 - T_4)$$

$$= 550.3 + (0.72)(793.1 - 550.3)$$

$$= 725.1 \text{ K}$$

$$w_{C,in} = 2(h_2 - h_1) = 2c_p(T_2 - T_1) = 2(5.1926 \text{ kJ/kg}\cdot\text{K})(550.3 - 300)\text{K} = 2599.4 \text{ kJ/kg}$$

$$w_{T,out} = 2(h_6 - h_7) = 2c_p(T_6 - T_7) = 2(5.1926 \text{ kJ/kg}\cdot\text{K})(1200 - 793.1)\text{K} = 4225.7 \text{ kJ/kg}$$

Thus,

$$r_{bw} = \frac{w_{C,in}}{w_{T,out}} = \frac{2599.4 \text{ kJ/kg}}{4225.7 \text{ kJ/kg}} = \mathbf{61.5\%}$$

$$q_{in} = (h_6 - h_5) + (h_8 - h_7) = c_p [(T_6 - T_5) + (T_8 - T_7)]$$

$$= (5.1926 \text{ kJ/kg}\cdot\text{K}) [(1200 - 725.1) + (1200 - 793.1)]\text{K} = 4578.8 \text{ kJ/kg}$$

$$w_{net} = w_{T,out} - w_{C,in} = 4225.7 - 2599.4 = 1626.3 \text{ kJ/kg}$$

$$\eta_{th} = \frac{w_{net}}{q_{in}} = \frac{1626.3 \text{ kJ/kg}}{4578.8 \text{ kJ/kg}} = \mathbf{35.5\%}$$

9-182 An ideal gas-turbine cycle with one stage of compression and two stages of expansion and regeneration is considered. The thermal efficiency of the cycle as a function of the compressor pressure ratio and the high-pressure turbine to compressor inlet temperature ratio is to be determined, and to be compared with the efficiency of the standard regenerative cycle.

Analysis The T - s diagram of the cycle is as shown in the figure. If the overall pressure ratio of the cycle is r_p , which is the pressure ratio across the compressor, then the pressure ratio across each turbine stage in the ideal case becomes $\sqrt{r_p}$. Using the isentropic relations, the temperatures at the compressor and turbine exit can be expressed as

$$T_5 = T_2 = T_1 \left(\frac{P_2}{P_1} \right)^{(k-1)/k} = T_1 (r_p)^{(k-1)/k}$$

$$T_7 = T_4 = T_3 \left(\frac{P_4}{P_3} \right)^{(k-1)/k} = T_3 \left(\frac{1}{\sqrt{r_p}} \right)^{(k-1)/k} = T_3 r_p^{(1-k)/2k}$$

$$T_6 = T_5 \left(\frac{P_6}{P_5} \right)^{(k-1)/k} = T_5 \left(\frac{1}{\sqrt{r_p}} \right)^{(k-1)/k} = T_2 r_p^{(1-k)/2k} = T_1 r_p^{(k-1)/k} r_p^{(1-k)/2k} = T_1 r_p^{(k-1)/2k}$$

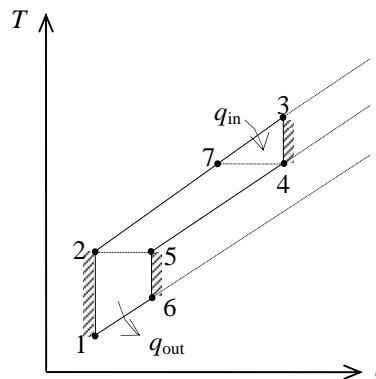

Then,

$$q_{\text{in}} = h_3 - h_7 = c_p (T_3 - T_7) = c_p T_3 (1 - r_p^{(1-k)/2k})$$

$$q_{\text{out}} = h_6 - h_1 = c_p (T_6 - T_1) = c_p T_1 (r_p^{(k-1)/2k} - 1)$$

and thus

$$\eta_{\text{th}} = 1 - \frac{q_{\text{out}}}{q_{\text{in}}} = 1 - \frac{c_p T_1 (r_p^{(k-1)/2k} - 1)}{c_p T_3 (1 - r_p^{(1-k)/2k})}$$

which simplifies to

$$\eta_{\text{th}} = 1 - \frac{T_1}{T_3} r_p^{(k-1)/2k}$$

The thermal efficiency of the single stage ideal regenerative cycle is given as

$$\eta_{\text{th}} = 1 - \frac{T_1}{T_3} r_p^{(k-1)/k}$$

Therefore, the regenerative cycle with two stages of expansion has a higher thermal efficiency than the standard regenerative cycle with a single stage of expansion for any given value of the pressure ratio r_p .

9-183 A gas-turbine plant operates on the regenerative Brayton cycle with reheating and intercooling. The back work ratio, the net work output, the thermal efficiency, the second-law efficiency, and the exergies at the exits of the combustion chamber and the regenerator are to be determined.

Assumptions 1 The air-standard assumptions are applicable. **2** Kinetic and potential energy changes are negligible. **3** Air is an ideal gas with variable specific heats.

Properties The gas constant of air is $R = 0.287 \text{ kJ/kg}\cdot\text{K}$.

Analysis (a) For this problem, we use the properties from EES software. Remember that for an ideal gas, enthalpy is a function of temperature only whereas entropy is functions of both temperature and pressure.

Optimum intercooling and reheating pressure is

$$P_2 = \sqrt{P_1 P_4} = \sqrt{(100)(1200)} = 346.4 \text{ kPa}$$

Process 1-2, 3-4: Compression

$$T_1 = 300 \text{ K} \longrightarrow h_1 = 300.43 \text{ kJ/kg}$$

$$\left. \begin{array}{l} T_1 = 300 \text{ K} \\ P_1 = 100 \text{ kPa} \end{array} \right\} s_1 = 5.7054 \text{ kJ/kg}\cdot\text{K}$$

$$\left. \begin{array}{l} P_2 = 346.4 \text{ kPa} \\ s_2 = s_1 = 5.7054 \text{ kJ/kg}\cdot\text{K} \end{array} \right\} h_{2s} = 428.79 \text{ kJ/kg}$$

$$\eta_C = \frac{h_{2s} - h_1}{h_2 - h_1} \longrightarrow 0.80 = \frac{428.79 - 300.43}{h_2 - 300.43} \longrightarrow h_2 = 460.88 \text{ kJ/kg}$$

$$T_3 = 350 \text{ K} \longrightarrow h_3 = 350.78 \text{ kJ/kg}$$

$$\left. \begin{array}{l} T_3 = 350 \text{ K} \\ P_3 = 346.4 \text{ kPa} \end{array} \right\} s_3 = 5.5040 \text{ kJ/kg}\cdot\text{K}$$

$$\left. \begin{array}{l} P_4 = 1200 \text{ kPa} \\ s_4 = s_3 = 5.5040 \text{ kJ/kg}\cdot\text{K} \end{array} \right\} h_{4s} = 500.42 \text{ kJ/kg}$$

$$\eta_C = \frac{h_{4s} - h_3}{h_4 - h_3} \longrightarrow 0.80 = \frac{500.42 - 350.78}{h_4 - 350.78} \longrightarrow h_4 = 537.83 \text{ kJ/kg}$$

Process 6-7, 8-9: Expansion

$$T_6 = 1400 \text{ K} \longrightarrow h_6 = 1514.9 \text{ kJ/kg}$$

$$\left. \begin{array}{l} T_6 = 1400 \text{ K} \\ P_6 = 1200 \text{ kPa} \end{array} \right\} s_6 = 6.6514 \text{ kJ/kg}\cdot\text{K}$$

$$\left. \begin{array}{l} P_7 = 346.4 \text{ kPa} \\ s_7 = s_6 = 6.6514 \text{ kJ/kg}\cdot\text{K} \end{array} \right\} h_{7s} = 1083.9 \text{ kJ/kg}$$

$$\eta_T = \frac{h_6 - h_7}{h_6 - h_{7s}} \longrightarrow 0.80 = \frac{1514.9 - h_7}{1514.9 - 1083.9} \longrightarrow h_7 = 1170.1 \text{ kJ/kg}$$

$$T_8 = 1300 \text{ K} \longrightarrow h_8 = 1395.6 \text{ kJ/kg}$$

$$\left. \begin{array}{l} T_8 = 1300 \text{ K} \\ P_8 = 346.4 \text{ kPa} \end{array} \right\} s_8 = 6.9196 \text{ kJ/kg}\cdot\text{K}$$

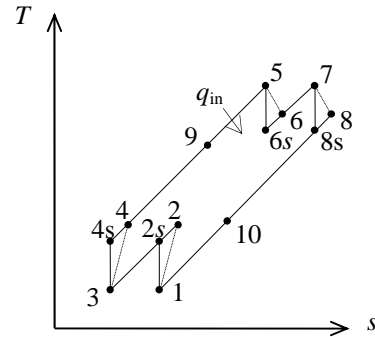

$$\left. \begin{aligned} P_9 &= 100 \text{ kPa} \\ s_9 &= s_8 = 6.9196 \text{ kJ/kg}\cdot\text{K} \end{aligned} \right\} h_{9s} = 996.00 \text{ kJ/kg}$$

$$\eta_T = \frac{h_8 - h_9}{h_8 - h_{9s}} \longrightarrow 0.80 = \frac{1395.6 - h_9}{1395.6 - 996.00} \longrightarrow h_9 = 1075.9 \text{ kJ/kg}$$

Cycle analysis:

$$w_{C,\text{in}} = h_2 - h_1 + h_4 - h_3 = 460.88 - 300.43 + 537.83 - 350.78 = 347.50 \text{ kJ/kg}$$

$$w_{T,\text{out}} = h_6 - h_7 + h_8 - h_9 = 1514.9 - 1170.1 + 1395.6 - 1075.9 = 664.50 \text{ kJ/kg}$$

$$r_{\text{bw}} = \frac{w_{C,\text{in}}}{w_{T,\text{out}}} = \frac{347.50}{664.50} = \mathbf{0.523}$$

$$w_{\text{net}} = w_{T,\text{out}} - w_{C,\text{in}} = 664.50 - 347.50 = \mathbf{317.0 \text{ kJ/kg}}$$

Regenerator analysis:

$$\varepsilon_{\text{regen}} = \frac{h_9 - h_{10}}{h_9 - h_4} \longrightarrow 0.75 = \frac{1075.9 - h_{10}}{1075.9 - 537.83} \longrightarrow h_{10} = 672.36 \text{ kJ/kg}$$

$$\left. \begin{aligned} h_{10} &= 672.36 \text{ K} \\ P_{10} &= 100 \text{ kPa} \end{aligned} \right\} s_{10} = 6.5157 \text{ kJ/kg}\cdot\text{K}$$

$$q_{\text{regen}} = h_9 - h_{10} = h_5 - h_4 \longrightarrow 1075.9 - 672.36 = h_5 - 537.83 \longrightarrow h_5 = 941.40 \text{ kJ/kg}$$

(b) $q_{\text{in}} = h_6 - h_5 = 1514.9 - 941.40 = 573.54 \text{ kJ/kg}$

$$\eta_{\text{th}} = \frac{w_{\text{net}}}{q_{\text{in}}} = \frac{317.0}{573.54} = \mathbf{0.553}$$

(c) The second-law efficiency of the cycle is defined as the ratio of actual thermal efficiency to the maximum possible thermal efficiency (Carnot efficiency). The maximum temperature for the cycle can be taken to be the turbine inlet temperature. That is,

$$\eta_{\text{max}} = 1 - \frac{T_1}{T_6} = 1 - \frac{300 \text{ K}}{1400 \text{ K}} = 0.786$$

and

$$\eta_{II} = \frac{\eta_{\text{th}}}{\eta_{\text{max}}} = \frac{0.553}{0.786} = \mathbf{0.704}$$

(d) The exergies at the combustion chamber exit and the regenerator exit are

$$\begin{aligned} x_6 &= h_6 - h_0 - T_0(s_6 - s_0) \\ &= (1514.9 - 300.43) \text{ kJ/kg} - (300 \text{ K})(6.6514 - 5.7054) \text{ kJ/kg}\cdot\text{K} = \mathbf{930.7 \text{ kJ/kg}} \end{aligned}$$

$$\begin{aligned} x_{10} &= h_{10} - h_0 - T_0(s_{10} - s_0) \\ &= (672.36 - 300.43) \text{ kJ/kg} - (300 \text{ K})(6.5157 - 5.7054) \text{ kJ/kg}\cdot\text{K} = \mathbf{128.8 \text{ kJ/kg}} \end{aligned}$$

9-184 The thermal efficiency of a two-stage gas turbine with regeneration, reheating and intercooling to that of a three-stage gas turbine is to be compared.

Assumptions 1 The air standard assumptions are applicable. **2** Air is an ideal gas with constant specific heats at room temperature. **3** Kinetic and potential energy changes are negligible.

Properties The properties of air at room temperature are $c_p = 1.005 \text{ kJ/kg}\cdot\text{K}$ and $k = 1.4$ (Table A-2a).

Analysis

Two Stages:

The pressure ratio across each stage is

$$r_p = \sqrt{16} = 4$$

The temperatures at the end of compression and expansion are

$$T_c = T_{\min} r_p^{(k-1)/k} = (283 \text{ K})(4)^{0.4/1.4} = 420.5 \text{ K}$$

$$T_e = T_{\max} \left(\frac{1}{r_p} \right)^{(k-1)/k} = (873 \text{ K}) \left(\frac{1}{4} \right)^{0.4/1.4} = 587.5 \text{ K}$$

The heat input and heat output are

$$q_{\text{in}} = 2c_p (T_{\max} - T_e) = 2(1.005 \text{ kJ/kg}\cdot\text{K})(873 - 587.5) \text{ K} = 573.9 \text{ kJ/kg}$$

$$q_{\text{out}} = 2c_p (T_c - T_{\min}) = 2(1.005 \text{ kJ/kg}\cdot\text{K})(420.5 - 283) \text{ K} = 276.4 \text{ kJ/kg}$$

The thermal efficiency of the cycle is then

$$\eta_{\text{th}} = 1 - \frac{q_{\text{out}}}{q_{\text{in}}} = 1 - \frac{276.4}{573.9} = \mathbf{0.518}$$

Three Stages:

The pressure ratio across each stage is

$$r_p = 16^{1/3} = 2.520$$

The temperatures at the end of compression and expansion are

$$T_c = T_{\min} r_p^{(k-1)/k} = (283 \text{ K})(2.520)^{0.4/1.4} = 368.5 \text{ K}$$

$$T_e = T_{\max} \left(\frac{1}{r_p} \right)^{(k-1)/k} = (873 \text{ K}) \left(\frac{1}{2.520} \right)^{0.4/1.4} = 670.4 \text{ K}$$

The heat input and heat output are

$$q_{\text{in}} = 3c_p (T_{\max} - T_e) = 3(1.005 \text{ kJ/kg}\cdot\text{K})(873 - 670.4) \text{ K} = 610.8 \text{ kJ/kg}$$

$$q_{\text{out}} = 3c_p (T_c - T_{\min}) = 3(1.005 \text{ kJ/kg}\cdot\text{K})(368.5 - 283) \text{ K} = 257.8 \text{ kJ/kg}$$

The thermal efficiency of the cycle is then

$$\eta_{\text{th}} = 1 - \frac{q_{\text{out}}}{q_{\text{in}}} = 1 - \frac{257.8}{610.8} = \mathbf{0.578}$$

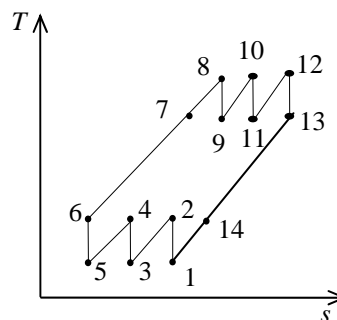
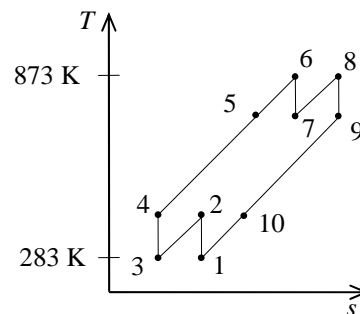

9-185E A pure jet engine operating on an ideal cycle is considered. The thrust force produced per unit mass flow rate is to be determined.

Assumptions 1 Steady operating conditions exist. 2 The air standard assumptions are applicable. 3 Air is an ideal gas with constant specific heats at room temperature. 4 The turbine work output is equal to the compressor work input.

Properties The properties of air at room temperature are $R = 0.3704$ psia·ft³/lbm·R (Table A-1E), $c_p = 0.24$ Btu/lbm·R and $k = 1.4$ (Table A-2Ea).

Analysis Working across the two isentropic processes of the cycle yields

$$T_2 = T_1 r_p^{(k-1)/k} = (490 \text{ R})(9)^{0.4/1.4} = 918.0 \text{ R}$$

$$T_5 = T_3 \left(\frac{1}{r_p} \right)^{(k-1)/k} = (1160 \text{ R}) \left(\frac{1}{9} \right)^{0.4/1.4} = 619.2 \text{ R}$$

The work input to the compressor is

$$w_C = c_p (T_2 - T_1) = (0.24 \text{ Btu/lbm} \cdot \text{R})(918.0 - 490) \text{ R} = 102.7 \text{ Btu/lbm}$$

An energy balance gives the excess enthalpy to be

$$\begin{aligned} \Delta h &= c_p (T_3 - T_5) - w_C \\ &= (0.24 \text{ Btu/lbm} \cdot \text{R})(1160 - 619.2) \text{ R} - 102.7 \text{ Btu/lbm} \\ &= 27.09 \text{ Btu/lbm} \end{aligned}$$

The velocity of the air at the engine exit is determined from

$$\Delta h = \frac{V_{\text{exit}}^2 - V_{\text{inlet}}^2}{2}$$

Rearranging,

$$\begin{aligned} V_{\text{exit}} &= \left(2\Delta h + V_{\text{inlet}}^2 \right)^{1/2} \\ &= \left[2(27.09 \text{ Btu/lbm}) \left(\frac{25,037 \text{ ft}^2/\text{s}^2}{1 \text{ Btu/lbm}} \right) + (1200 \text{ ft/s})^2 \right]^{1/2} \\ &= 1672 \text{ ft/s} \end{aligned}$$

The specific impulse is then

$$\frac{F}{\dot{m}} = V_{\text{exit}} - V_{\text{inlet}} = 1672 - 1200 = \mathbf{472 \text{ m/s}}$$

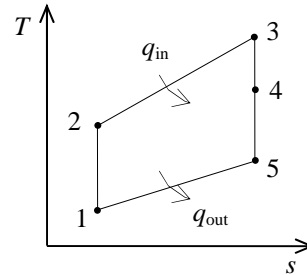

9-186 A simple ideal Brayton cycle with air as the working fluid operates between the specified temperature limit. The net work is to be determined using constant and variable specific heats.

Assumptions 1 Steady operating conditions exist. **2** The air-standard assumptions are applicable. **3** Kinetic and potential energy changes are negligible.

Properties The properties of air at room temperature are $c_p = 1.005 \text{ kJ/kg}\cdot\text{K}$ and $k = 1.4$ (Table A-2a).

Analysis (a) Constant specific heats:

$$T_2 = T_1 r_p^{(k-1)/k} = (273 \text{ K})(15)^{0.4/1.4} = 591.8 \text{ K}$$

$$T_4 = T_3 \left(\frac{1}{r_p} \right)^{(k-1)/k} = (873 \text{ K}) \left(\frac{1}{15} \right)^{0.4/1.4} = 402.7 \text{ K}$$

$$\begin{aligned} w_{\text{net}} &= w_{\text{turb}} - w_{\text{comp}} \\ &= c_p (T_3 - T_4) - c_p (T_2 - T_1) \\ &= c_p (T_3 - T_4 + T_1 - T_2) \\ &= (1.005 \text{ kJ/kg}\cdot\text{K})(873 - 402.7 + 273 - 591.8) \text{ K} \\ &= \mathbf{152.3 \text{ kJ/kg}} \end{aligned}$$

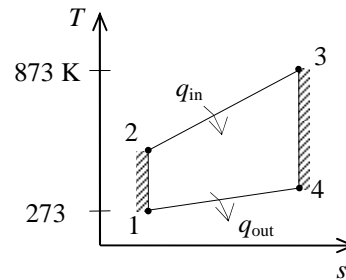

(b) Variable specific heats: (using air properties from Table A-17)

$$T_1 = 273 \text{ K} \longrightarrow \begin{aligned} h_1 &= 273.12 \text{ kJ/kg} \\ P_{r1} &= 0.9980 \end{aligned}$$

$$P_{r2} = \frac{P_2}{P_1} P_{r1} = (15)(0.9980) = 14.97 \longrightarrow h_2 = 592.69 \text{ kJ/kg}$$

$$T_3 = 873 \text{ K} \longrightarrow \begin{aligned} h_3 &= 902.76 \text{ kJ/kg} \\ P_{r3} &= 66.92 \end{aligned}$$

$$P_{r4} = \frac{P_4}{P_3} P_{r3} = \left(\frac{1}{15} \right) (66.92) = 4.461 \longrightarrow h_4 = 419.58 \text{ kJ/kg}$$

$$\begin{aligned} w_{\text{net}} &= w_{\text{turb}} - w_{\text{comp}} \\ &= (h_3 - h_4) - (h_2 - h_1) \\ &= (902.76 - 419.58) - (592.69 - 273.12) \\ &= \mathbf{163.6 \text{ kJ/kg}} \end{aligned}$$

9-187 An Otto cycle with a compression ratio of 8 is considered. The thermal efficiency is to be determined using constant and variable specific heats.

Assumptions 1 The air-standard assumptions are applicable. **2** Kinetic and potential energy changes are negligible.

Properties The properties of air at room temperature are $R = 0.287 \text{ kPa}\cdot\text{m}^3/\text{kg}\cdot\text{K}$, $c_p = 1.005 \text{ kJ/kg}\cdot\text{K}$, $c_v = 0.718 \text{ kJ/kg}\cdot\text{K}$, and $k = 1.4$ (Table A-2a).

Analysis (a) Constant specific heats:

$$\eta_{\text{th}} = 1 - \frac{1}{r^{k-1}} = 1 - \frac{1}{8^{1.4-1}} = \mathbf{0.5647}$$

(b) Variable specific heats: (using air properties from Table A-17)

Process 1-2: isentropic compression.

$$T_1 = 283 \text{ K} \longrightarrow \begin{matrix} u_1 = 201.9 \text{ kJ/kg} \\ v_{r1} = 718.9 \end{matrix}$$

$$v_{r2} = \frac{v_2}{v_1} v_{r1} = \frac{1}{r} v_{r1} = \frac{1}{8} (718.9) = 89.86 \longrightarrow u_2 = 463.76 \text{ kJ/kg}$$

Process 2-3: $v = \text{constant}$ heat addition.

$$T_3 = 1173 \text{ K} \longrightarrow \begin{matrix} u_3 = 909.39 \text{ kJ/kg} \\ v_{r3} = 15.529 \end{matrix}$$

$$q_{\text{in}} = u_3 - u_2 = 909.39 - 463.76 = 445.63 \text{ kJ/kg}$$

Process 3-4: isentropic expansion.

$$v_{r4} = \frac{v_4}{v_3} v_{r3} = r v_{r3} = (8)(15.529) = 124.2 \longrightarrow u_4 = 408.06 \text{ kJ/kg}$$

Process 4-1: $v = \text{constant}$ heat rejection.

$$q_{\text{out}} = u_4 - u_1 = 408.06 - 201.9 = 206.16 \text{ kJ/kg}$$

$$\eta_{\text{th}} = 1 - \frac{q_{\text{out}}}{q_{\text{in}}} = 1 - \frac{206.16 \text{ kJ/kg}}{445.63 \text{ kJ/kg}} = \mathbf{0.5374}$$

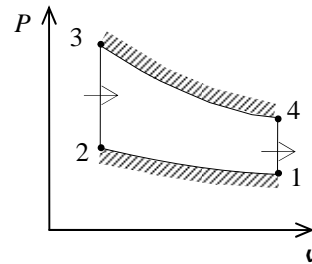

9-188 An ideal diesel engine with air as the working fluid has a compression ratio of 22. The thermal efficiency is to be determined using constant and variable specific heats.

Assumptions 1 The air-standard assumptions are applicable. **2** Kinetic and potential energy changes are negligible. **3** Air is an ideal gas with constant specific heats.

Properties The properties of air at room temperature are $c_p = 1.005 \text{ kJ/kg}\cdot\text{K}$, $c_v = 0.718 \text{ kJ/kg}\cdot\text{K}$, $R = 0.287 \text{ kJ/kg}\cdot\text{K}$, and $k = 1.4$ (Table A-2a).

Analysis (a) Constant specific heats:

Process 1-2: isentropic compression.

$$T_2 = T_1 \left(\frac{v_1}{v_2} \right)^{k-1} = (288 \text{ K})(22)^{0.4} = 991.7 \text{ K}$$

Process 2-3: $P = \text{constant}$ heat addition.

$$\frac{P_3 v_3}{T_3} = \frac{P_2 v_2}{T_2} \longrightarrow \frac{v_3}{v_2} = \frac{T_3}{T_2} = \frac{1473 \text{ K}}{991.7 \text{ K}} = 1.485$$

Process 3-4: isentropic expansion.

$$T_4 = T_3 \left(\frac{v_3}{v_4} \right)^{k-1} = T_3 \left(\frac{1.485 v_2}{v_4} \right)^{k-1} = T_3 \left(\frac{1.485}{r} \right)^{k-1} = (1473 \text{ K}) \left(\frac{1.485}{22} \right)^{0.4} = 501.1 \text{ K}$$

$$q_{\text{in}} = h_3 - h_2 = c_p (T_3 - T_2) = (1.005 \text{ kJ/kg}\cdot\text{K})(1473 - 991.7) \text{ K} = 483.7 \text{ kJ/kg}$$

$$q_{\text{out}} = u_4 - u_1 = c_v (T_4 - T_1) = (0.718 \text{ kJ/kg}\cdot\text{K})(501.1 - 288) \text{ K} = 153.0 \text{ kJ/kg}$$

$$w_{\text{net,out}} = q_{\text{in}} - q_{\text{out}} = 483.7 - 153.0 = 330.7 \text{ kJ/kg}$$

$$\eta_{\text{th}} = \frac{w_{\text{net,out}}}{q_{\text{in}}} = \frac{330.7 \text{ kJ/kg}}{473.7 \text{ kJ/kg}} = \mathbf{0.698}$$

(b) Variable specific heats: (using air properties from Table A-17)

Process 1-2: isentropic compression.

$$T_1 = 288 \text{ K} \longrightarrow \begin{aligned} u_1 &= 205.48 \text{ kJ/kg} \\ v_{r1} &= 688.1 \end{aligned}$$

$$v_{r2} = \frac{v_2}{v_1} v_{r1} = \frac{1}{r} v_{r1} = \frac{1}{22} (688.1) = 31.28 \longrightarrow \begin{aligned} T_2 &= 929.2 \text{ K} \\ h_2 &= 965.73 \text{ kJ/kg} \end{aligned}$$

Process 2-3: $P = \text{constant}$ heat addition.

$$\frac{P_3 v_3}{T_3} = \frac{P_2 v_2}{T_2} \longrightarrow \frac{v_3}{v_2} = \frac{T_3}{T_2} = \frac{1473 \text{ K}}{929.2 \text{ K}} = 1.585$$

$$T_3 = 1473 \text{ K} \longrightarrow \begin{aligned} h_3 &= 1603.33 \text{ kJ/kg} \\ v_{r3} &= 7.585 \end{aligned}$$

$$q_{\text{in}} = h_3 - h_2 = 1603.33 - 965.73 = 637.6 \text{ kJ/kg}$$

Process 3-4: isentropic expansion.

$$v_{r4} = \frac{v_4}{v_3} v_{r3} = \frac{v_4}{1.585 v_2} v_{r3} = \frac{r}{1.585} v_{r3} = \frac{22}{1.585} (7.585) = 105.3 \longrightarrow u_4 = 435.61 \text{ kJ/kg}$$

Process 4-1: $v = \text{constant}$ heat rejection.

$$q_{\text{out}} = u_4 - u_1 = 435.61 - 205.48 = 230.13 \text{ kJ/kg}$$

$$\text{Then } \eta_{\text{th}} = 1 - \frac{q_{\text{out}}}{q_{\text{in}}} = 1 - \frac{230.13 \text{ kJ/kg}}{637.6 \text{ kJ/kg}} = \mathbf{0.639}$$

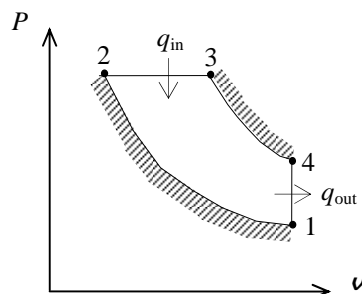

9-189 The electricity and the process heat requirements of a manufacturing facility are to be met by a cogeneration plant consisting of a gas-turbine and a heat exchanger for steam production. The mass flow rate of the air in the cycle, the back work ratio, the thermal efficiency, the rate at which steam is produced in the heat exchanger, and the utilization efficiency of the cogeneration plant are to be determined.

Assumptions 1 The air-standard assumptions are applicable. **2** Kinetic and potential energy changes are negligible. **3** Air is an ideal gas with variable specific heats.

Analysis (a) For this problem, we use the properties of air from EES software. Remember that for an ideal gas, enthalpy is a function of temperature only whereas entropy is functions of both temperature and pressure.

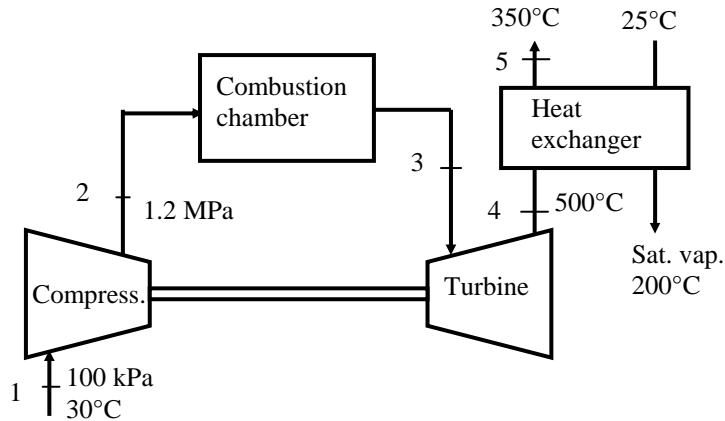

Process 1-2: Compression

$$T_1 = 30^\circ\text{C} \longrightarrow h_1 = 303.60 \text{ kJ/kg}$$

$$\left. \begin{array}{l} T_1 = 30^\circ\text{C} \\ P_1 = 100 \text{ kPa} \end{array} \right\} s_1 = 5.7159 \text{ kJ/kg} \cdot \text{K}$$

$$\left. \begin{array}{l} P_2 = 1200 \text{ kPa} \\ s_2 = s_1 = 5.7159 \text{ kJ/kg} \cdot \text{K} \end{array} \right\} h_{2s} = 617.37 \text{ kJ/kg}$$

$$\eta_C = \frac{h_{2s} - h_1}{h_2 - h_1} \longrightarrow 0.82 = \frac{617.37 - 303.60}{h_2 - 303.60} \longrightarrow h_2 = 686.24 \text{ kJ/kg}$$

Process 3-4: Expansion

$$T_4 = 500^\circ\text{C} \longrightarrow h_4 = 792.62 \text{ kJ/kg}$$

$$\eta_T = \frac{h_3 - h_4}{h_3 - h_{4s}} \longrightarrow 0.82 = \frac{h_3 - 792.62}{h_3 - h_{4s}}$$

We cannot find the enthalpy at state 3 directly. However, using the following lines in EES together with the isentropic efficiency relation, we find $h_3 = 1404.7 \text{ kJ/kg}$, $T_3 = 1034^\circ\text{C}$, $s_3 = 6.5699 \text{ kJ/kg} \cdot \text{K}$. The solution by hand would require a trial-error approach.

$$h_3 = \text{enthalpy}(\text{Air}, T=T_3)$$

$$s_3 = \text{entropy}(\text{Air}, T=T_3, P=P_2)$$

$$h_{4s} = \text{enthalpy}(\text{Air}, P=P_1, s=s_3)$$

Also,

$$T_5 = 350^\circ\text{C} \longrightarrow h_5 = 631.44 \text{ kJ/kg}$$

The inlet water is compressed liquid at 25°C and at the saturation pressure of steam at 200°C (1555 kPa). This is not available in the tables but we can obtain it in EES. The alternative is to use saturated liquid enthalpy at the given temperature.

$$\left. \begin{array}{l} T_{w1} = 25^\circ\text{C} \\ P_1 = 1555 \text{ kPa} \end{array} \right\} h_{w1} = 106.27 \text{ kJ/kg}$$

$$\left. \begin{array}{l} T_{w2} = 200^\circ\text{C} \\ x_2 = 1 \end{array} \right\} h_{w2} = 2792.0 \text{ kJ/kg}$$

The net work output is

$$w_{C,\text{in}} = h_2 - h_1 = 686.24 - 303.60 = 382.64 \text{ kJ/kg}$$

$$w_{T,\text{out}} = h_3 - h_4 = 1404.7 - 792.62 = 612.03 \text{ kJ/kg}$$

$$w_{\text{net}} = w_{T,\text{out}} - w_{C,\text{in}} = 612.03 - 382.64 = 229.39 \text{ kJ/kg}$$

The mass flow rate of air is

$$\dot{m}_a = \frac{\dot{W}_{\text{net}}}{w_{\text{net}}} = \frac{800 \text{ kJ/s}}{229.39 \text{ kJ/kg}} = \mathbf{3.487 \text{ kg/s}}$$

(b) The back work ratio is

$$r_{\text{bw}} = \frac{w_{C,\text{in}}}{w_{T,\text{out}}} = \frac{382.64}{612.03} = \mathbf{0.625}$$

The rate of heat input and the thermal efficiency are

$$\dot{Q}_{\text{in}} = \dot{m}_a (h_3 - h_2) = (3.487 \text{ kg/s})(1404.7 - 686.24) \text{ kJ/kg} = 2505 \text{ kW}$$

$$\eta_{\text{th}} = \frac{\dot{W}_{\text{net}}}{\dot{Q}_{\text{in}}} = \frac{800 \text{ kW}}{2505 \text{ kW}} = \mathbf{0.319}$$

(c) An energy balance on the heat exchanger gives

$$\dot{m}_a (h_4 - h_5) = \dot{m}_w (h_{w2} - h_{w1})$$

$$(3.487 \text{ kg/s})(792.62 - 631.44) \text{ kJ/kg} = \dot{m}_w (2792.0 - 106.27) \text{ kJ/kg} \longrightarrow \dot{m}_w = \mathbf{0.2093 \text{ kg/s}}$$

(d) The heat supplied to the water in the heat exchanger (process heat) and the utilization efficiency are

$$\dot{Q}_p = \dot{m}_w (h_{w2} - h_{w1}) = (0.2093 \text{ kg/s})(2792.0 - 106.27) \text{ kJ/kg} = 562.1 \text{ kW}$$

$$\varepsilon_u = \frac{\dot{W}_{\text{net}} + \dot{Q}_p}{\dot{Q}_{\text{in}}} = \frac{800 + 562.1}{2505 \text{ kW}} = \mathbf{0.544}$$

9-190 A turbojet aircraft flying is considered. The pressure of the gases at the turbine exit, the mass flow rate of the air through the compressor, the velocity of the gases at the nozzle exit, the propulsive power, and the propulsive efficiency of the cycle are to be determined.

Assumptions 1 The air-standard assumptions are applicable. **2** Potential energy changes are negligible. **3** Air is an ideal gas with variable specific heats.

Properties The gas constant of air is $R = 0.287 \text{ kJ/kg}\cdot\text{K}$ (Table A-1).

Analysis (a) For this problem, we use the properties from EES software. Remember that for an ideal gas, enthalpy is a function of temperature only whereas entropy is functions of both temperature and pressure.

Diffuser, Process 1-2:

$$T_1 = -35^\circ\text{C} \longrightarrow h_1 = 238.23 \text{ kJ/kg}$$

$$h_1 + \frac{V_1^2}{2} = h_2 + \frac{V_2^2}{2}$$

$$(238.23 \text{ kJ/kg}) + \frac{(900/3.6 \text{ m/s})^2}{2} \left(\frac{1 \text{ kJ/kg}}{1000 \text{ m}^2/\text{s}^2} \right) = h_2 + \frac{(15 \text{ m/s})^2}{2} \left(\frac{1 \text{ kJ/kg}}{1000 \text{ m}^2/\text{s}^2} \right) \longrightarrow h_2 = 269.37 \text{ kJ/kg}$$

$$\left. \begin{array}{l} h_2 = 269.37 \text{ kJ/kg} \\ P_2 = 50 \text{ kPa} \end{array} \right\} s_2 = 5.7951 \text{ kJ/kg}\cdot\text{K}$$

Compressor, Process 2-3:

$$\left. \begin{array}{l} P_3 = 450 \text{ kPa} \\ s_3 = s_2 = 5.7951 \text{ kJ/kg}\cdot\text{K} \end{array} \right\} h_{3s} = 505.19 \text{ kJ/kg}$$

$$\eta_C = \frac{h_{3s} - h_2}{h_3 - h_2} \longrightarrow 0.83 = \frac{505.19 - 269.37}{h_3 - 269.37} \longrightarrow h_3 = 553.50 \text{ kJ/kg}$$

Turbine, Process 3-4:

$$T_4 = 950^\circ\text{C} \longrightarrow h_4 = 1304.8 \text{ kJ/kg}$$

$$h_3 - h_2 = h_4 - h_5 \longrightarrow 553.50 - 269.37 = 1304.8 - h_5 \longrightarrow h_5 = 1020.6 \text{ kJ/kg}$$

where the mass flow rates through the compressor and the turbine are assumed equal.

$$\eta_T = \frac{h_4 - h_5}{h_4 - h_{5s}} \longrightarrow 0.83 = \frac{1304.8 - 1020.6}{1304.8 - h_{5s}} \longrightarrow h_{5s} = 962.45 \text{ kJ/kg}$$

$$\left. \begin{array}{l} T_4 = 950^\circ\text{C} \\ P_4 = 450 \text{ kPa} \end{array} \right\} s_4 = 6.7725 \text{ kJ/kg}\cdot\text{K}$$

$$\left. \begin{array}{l} h_{5s} = 962.45 \text{ kJ/kg} \\ s_5 = s_4 = 6.7725 \text{ kJ/kg}\cdot\text{K} \end{array} \right\} P_5 = \mathbf{147.4 \text{ kPa}}$$

(b) The mass flow rate of the air through the compressor is

$$\dot{m} = \frac{\dot{W}_C}{h_3 - h_2} = \frac{500 \text{ kJ/s}}{(553.50 - 269.37) \text{ kJ/kg}} = \mathbf{1.760 \text{ kg/s}}$$

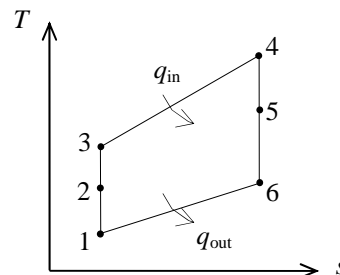

(c) *Nozzle, Process 5-6:*

$$\left. \begin{array}{l} h_5 = 1020.6 \text{ kJ/kg} \\ P_5 = 147.4 \text{ kPa} \end{array} \right\} s_5 = 6.8336 \text{ kJ/kg} \cdot \text{K}$$

$$\left. \begin{array}{l} P_6 = 40 \text{ kPa} \\ s_6 = s_5 = 6.8336 \text{ kJ/kg} \cdot \text{K} \end{array} \right\} h_{6s} = 709.66 \text{ kJ/kg}$$

$$\eta_N = \frac{h_5 - h_6}{h_5 - h_{6s}} \longrightarrow 0.83 = \frac{1020.6 - h_6}{1020.6 - 709.66} \longrightarrow h_6 = 762.52 \text{ kJ/kg}$$

$$h_5 + \frac{V_5^2}{2} = h_6 + \frac{V_6^2}{2}$$

$$(1020.6 \text{ kJ/kg}) + 0 = 762.52 \text{ kJ/kg} + \frac{V_6^2}{2} \left(\frac{1 \text{ kJ/kg}}{1000 \text{ m}^2/\text{s}^2} \right) \longrightarrow V_6 = \mathbf{718.5 \text{ m/s}}$$

where the velocity at nozzle inlet is assumed zero.

(d) The propulsive power and the propulsive efficiency are

$$\dot{W}_p = \dot{m}(V_6 - V_1)V_1 = (1.76 \text{ kg/s})(718.5 \text{ m/s} - 250 \text{ m/s})(250 \text{ m/s}) \left(\frac{1 \text{ kJ/kg}}{1000 \text{ m}^2/\text{s}^2} \right) = \mathbf{206.1 \text{ kW}}$$

$$\dot{Q}_{\text{in}} = \dot{m}(h_4 - h_3) = (1.76 \text{ kg/s})(1304.8 - 553.50) \text{ kJ/kg} = 1322 \text{ kW}$$

$$\eta_p = \frac{\dot{W}_p}{\dot{Q}_{\text{in}}} = \frac{206.1 \text{ kW}}{1322 \text{ kW}} = \mathbf{0.156}$$

9-191 EES The effects of compression ratio on the net work output and the thermal efficiency of the Otto cycle for given operating conditions is to be investigated.

Analysis Using EES, the problem is solved as follows:

"Input Data"

T[1]=300 [K]
P[1]=100 [kPa]
T[3] = 2000 [K]
r_comp = 12

"Process 1-2 is isentropic compression"

s[1]=entropy(air,T=T[1],P=P[1])
s[2]=s[1]
T[2]=temperature(air, s=s[2], P=P[2])
P[2]*v[2]/T[2]=P[1]*v[1]/T[1]
P[1]*v[1]=R*T[1]
R=0.287 [kJ/kg-K]
V[2] = V[1]/ r_comp

"Conservation of energy for process 1 to 2"

q_12 - w_12 = DELTAu_12
q_12 =0"isentropic process"
DELTAu_12=intenergy(air,T=T[2])-intenergy(air,T=T[1])

"Process 2-3 is constant volume heat addition"

v[3]=v[2]
s[3]=entropy(air, T=T[3], P=P[3])
P[3]*v[3]=R*T[3]

"Conservation of energy for process 2 to 3"

q_23 - w_23 = DELTAu_23
w_23 =0"constant volume process"
DELTAu_23=intenergy(air,T=T[3])-intenergy(air,T=T[2])

"Process 3-4 is isentropic expansion"

s[4]=s[3]
s[4]=entropy(air,T=T[4],P=P[4])
P[4]*v[4]=R*T[4]

"Conservation of energy for process 3 to 4"

q_34 -w_34 = DELTAu_34
q_34 =0"isentropic process"
DELTAu_34=intenergy(air,T=T[4])-intenergy(air,T=T[3])

"Process 4-1 is constant volume heat rejection"

V[4] = V[1]
"Conservation of energy for process 4 to 1"
q_41 - w_41 = DELTAu_41
w_41 =0 "constant volume process"
DELTAu_41=intenergy(air,T=T[1])-intenergy(air,T=T[4])

q_in_total=q_23
q_out_total = -q_41
w_net = w_12+w_23+w_34+w_41
Eta_th=w_net/q_in_total*Convert(, %) "Thermal efficiency, in percent"

η_{th} [%]	r_{comp}	W_{net} [kJ/kg]
45.83	6	567.4
48.67	7	589.3
51.03	8	604.9
53.02	9	616.2
54.74	10	624.3
56.24	11	630
57.57	12	633.8
58.75	13	636.3
59.83	14	637.5
60.8	15	637.9

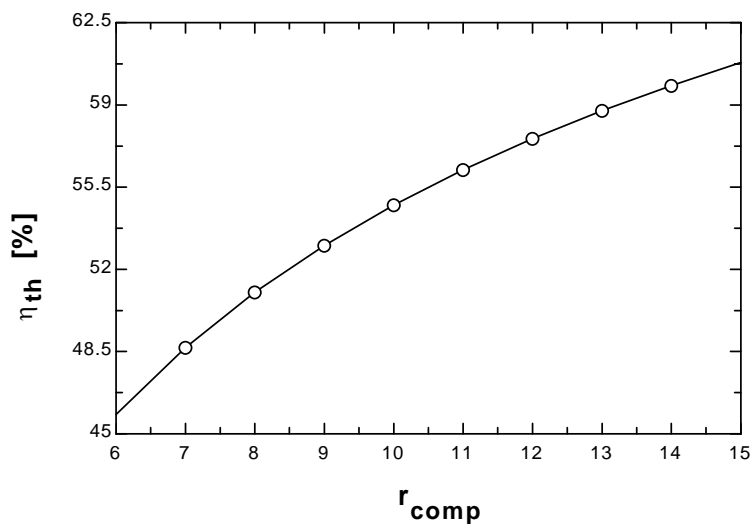
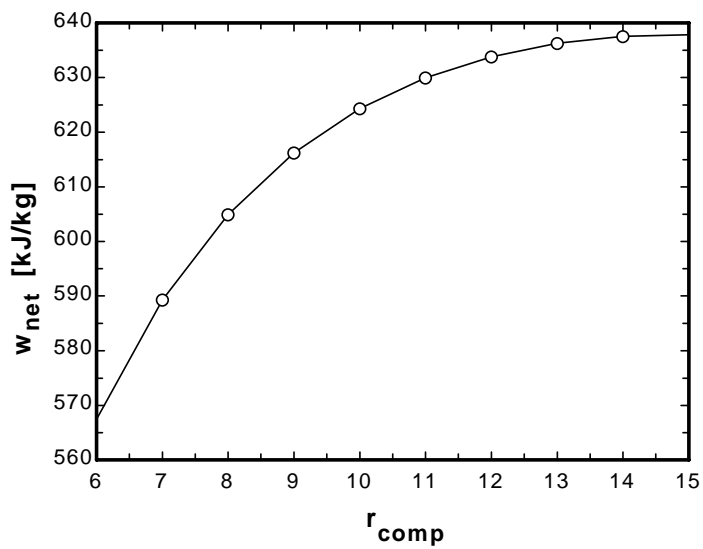

9-192 The effects of pressure ratio on the net work output and the thermal efficiency of a simple Brayton cycle is to be investigated. The pressure ratios at which the net work output and the thermal efficiency are maximum are to be determined.

Analysis Using EES, the problem is solved as follows:

P_ratio = 8
 T[1] = 300 [K]
 P[1] = 100 [kPa]
 T[3] = 1800 [K]
 m_dot = 1 [kg/s]
 Eta_c = 100/100
 Eta_t = 100/100

"Inlet conditions"

h[1]=ENTHALPY(Air,T=T[1])
 s[1]=ENTROPY(Air,T=T[1],P=P[1])

"Compressor analysis"

s_s[2]=s[1] "For the ideal case the entropies are constant across the compressor"
 P_ratio=P[2]/P[1]"Definition of pressure ratio - to find P[2]"
 T_s[2]=TEMPERATURE(Air,s=s_s[2],P=P[2]) "T_s[2] is the isentropic value of T[2] at compressor exit"
 h_s[2]=ENTHALPY(Air,T=T_s[2])
 Eta_c =(h_s[2]-h[1])/(h[2]-h[1]) "Compressor adiabatic efficiency; Eta_c = W_dot_c_ideal/W_dot_c_actual. "
 m_dot*h[1] +W_dot_c=m_dot*h[2] "SSSF First Law for the actual compressor, assuming: adiabatic, ke=pe=0"

"External heat exchanger analysis"

P[3]=P[2]"process 2-3 is SSSF constant pressure"
 h[3]=ENTHALPY(Air,T=T[3])
 m_dot*h[2] + Q_dot_in= m_dot*h[3]"SSSF First Law for the heat exchanger, assuming W=0, ke=pe=0"

"Turbine analysis"

s[3]=ENTROPY(Air,T=T[3],P=P[3])
 s_s[4]=s[3] "For the ideal case the entropies are constant across the turbine"
 P_ratio= P[3] /P[4]
 T_s[4]=TEMPERATURE(Air,s=s_s[4],P=P[4]) "Ts[4] is the isentropic value of T[4] at turbine exit"
 h_s[4]=ENTHALPY(Air,T=T_s[4]) "Eta_t = W_dot_t /Wts_dot turbine adiabatic efficiency, Wts_dot > W_dot_t"
 Eta_t=(h[3]-h[4])/(h[3]-h_s[4])
 m_dot*h[3] = W_dot_t + m_dot*h[4] "SSSF First Law for the actual compressor, assuming: adiabatic, ke=pe=0"

"Cycle analysis"

W_dot_net=W_dot_t-W_dot_c"Definition of the net cycle work, kW"
 Eta=W_dot_net/Q_dot_in"Cycle thermal efficiency"
 Bwr=W_dot_c/W_dot_t "Back work ratio"
 "The following state points are determined only to produce a T-s plot"
 T[2]=temperature('air',h=h[2])
 T[4]=temperature('air',h=h[4])
 s[2]=entropy('air',T=T[2],P=P[2])
 s[4]=entropy('air',T=T[4],P=P[4])

Bwr	η	P_{ratio}	W_c [kW]	W_{net} [kW]	W_t [kW]	Q_{in} [kW]
0.254	0.3383	5	175.8	516.3	692.1	1526
0.2665	0.3689	6	201.2	553.7	754.9	1501
0.2776	0.3938	7	223.7	582.2	805.9	1478
0.2876	0.4146	8	244.1	604.5	848.5	1458
0.2968	0.4324	9	262.6	622.4	885	1439
0.3052	0.4478	10	279.7	637	916.7	1422
0.313	0.4615	11	295.7	649	944.7	1406
0.3203	0.4736	12	310.6	659.1	969.6	1392
0.3272	0.4846	13	324.6	667.5	992.1	1378
0.3337	0.4945	14	337.8	674.7	1013	1364
0.3398	0.5036	15	350.4	680.8	1031	1352
0.3457	0.512	16	362.4	685.9	1048	1340
0.3513	0.5197	17	373.9	690.3	1064	1328
0.3567	0.5269	18	384.8	694.1	1079	1317
0.3618	0.5336	19	395.4	697.3	1093	1307
0.3668	0.5399	20	405.5	700	1106	1297
0.3716	0.5458	21	415.3	702.3	1118	1287
0.3762	0.5513	22	424.7	704.3	1129	1277
0.3806	0.5566	23	433.8	705.9	1140	1268
0.385	0.5615	24	442.7	707.2	1150	1259
0.3892	0.5663	25	451.2	708.3	1160	1251
0.3932	0.5707	26	459.6	709.2	1169	1243
0.3972	0.575	27	467.7	709.8	1177	1234
0.401	0.5791	28	475.5	710.3	1186	1227
0.4048	0.583	29	483.2	710.6	1194	1219
0.4084	0.5867	30	490.7	710.7	1201	1211
0.412	0.5903	31	498	710.8	1209	1204
0.4155	0.5937	32	505.1	710.7	1216	1197
0.4189	0.597	33	512.1	710.4	1223	1190
0.4222	0.6002	34	518.9	710.1	1229	1183

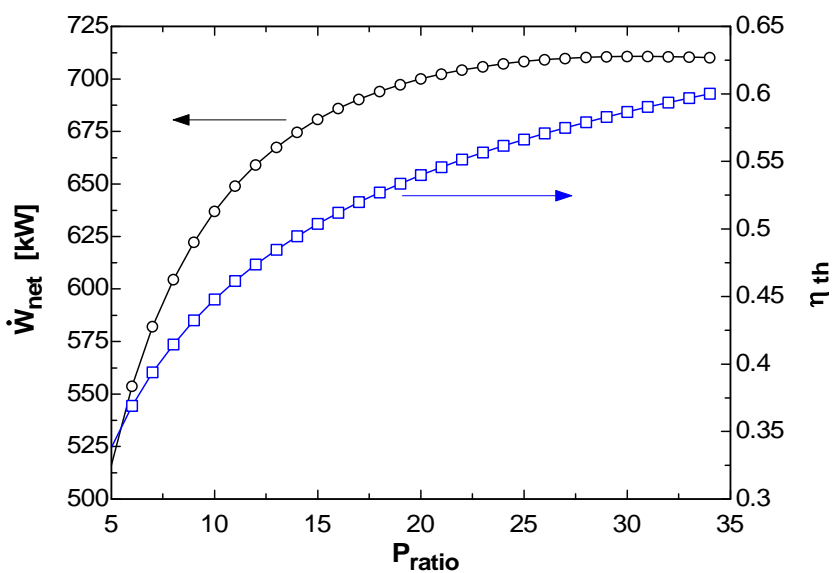

9-193 EES The effects of pressure ratio on the net work output and the thermal efficiency of a simple Brayton cycle is to be investigated assuming adiabatic efficiencies of 85 percent for both the turbine and the compressor. The pressure ratios at which the net work output and the thermal efficiency are maximum are to be determined.

Analysis Using EES, the problem is solved as follows:

```
P_ratio = 8
T[1] = 300 [K]
P[1] = 100 [kPa]
T[3] = 1800 [K]
m_dot = 1 [kg/s]
Eta_c = 85/100
Eta_t = 85/100
```

"Inlet conditions"

```
h[1]=ENTHALPY(Air,T=T[1])
s[1]=ENTROPY(Air,T=T[1],P=P[1])
```

"Compressor analysis"

```
s_s[2]=s[1] "For the ideal case the entropies are constant across the compressor"
P_ratio=P[2]/P[1]"Definition of pressure ratio - to find P[2]"
T_s[2]=TEMPERATURE(Air,s=s_s[2],P=P[2]) "T_s[2] is the isentropic value of T[2] at
compressor exit"
```

```
h_s[2]=ENTHALPY(Air,T=T_s[2])
Eta_c =(h_s[2]-h[1])/(h[2]-h[1]) "Compressor adiabatic efficiency; Eta_c =
W_dot_c_ideal/W_dot_c_actual. "
```

```
m_dot*h[1] +W_dot_c=m_dot*h[2] "SSSF First Law for the actual compressor, assuming:
adiabatic, ke=pe=0"
```

"External heat exchanger analysis"

```
P[3]=P[2]"process 2-3 is SSSF constant pressure"
```

```
h[3]=ENTHALPY(Air,T=T[3])
m_dot*h[2] + Q_dot_in= m_dot*h[3]"SSSF First Law for the heat exchanger, assuming W=0,
ke=pe=0"
```

"Turbine analysis"

```
s[3]=ENTROPY(Air,T=T[3],P=P[3])
s_s[4]=s[3] "For the ideal case the entropies are constant across the turbine"
P_ratio= P[3] /P[4]
T_s[4]=TEMPERATURE(Air,s=s_s[4],P=P[4]) "Ts[4] is the isentropic value of T[4] at turbine exit"
h_s[4]=ENTHALPY(Air,T=T_s[4]) "Eta_t = W_dot_t /Wts_dot turbine adiabatic efficiency,
Wts_dot > W_dot_t"
```

```
Eta_t=(h[3]-h[4])/(h[3]-h_s[4])
m_dot*h[3] = W_dot_t + m_dot*h[4] "SSSF First Law for the actual compressor, assuming:
adiabatic, ke=pe=0"
```

"Cycle analysis"

```
W_dot_net=W_dot_t-W_dot_c"Definition of the net cycle work, kW"
```

```
Eta=W_dot_net/Q_dot_in"Cycle thermal efficiency"
```

```
Bwr=W_dot_c/W_dot_t "Back work ratio"
```

"The following state points are determined only to produce a T-s plot"

```
T[2]=temperature('air',h=h[2])
T[4]=temperature('air',h=h[4])
s[2]=entropy('air',T=T[2],P=P[2])
s[4]=entropy('air',T=T[4],P=P[4])
```

Bwr	η	P_{ratio}	W_c [kW]	W_{net} [kW]	W_t [kW]	Q_{in} [kW]
0.3515	0.2551	5	206.8	381.5	588.3	1495
0.3689	0.2764	6	236.7	405	641.7	1465
0.3843	0.2931	7	263.2	421.8	685	1439
0.3981	0.3068	8	287.1	434.1	721.3	1415
0.4107	0.3182	9	309	443.3	752.2	1393
0.4224	0.3278	10	329.1	450.1	779.2	1373
0.4332	0.3361	11	347.8	455.1	803	1354
0.4433	0.3432	12	365.4	458.8	824.2	1337
0.4528	0.3495	13	381.9	461.4	843.3	1320
0.4618	0.355	14	397.5	463.2	860.6	1305
0.4704	0.3599	15	412.3	464.2	876.5	1290
0.4785	0.3643	16	426.4	464.7	891.1	1276
0.4862	0.3682	17	439.8	464.7	904.6	1262
0.4937	0.3717	18	452.7	464.4	917.1	1249
0.5008	0.3748	19	465.1	463.6	928.8	1237
0.5077	0.3777	20	477.1	462.6	939.7	1225
0.5143	0.3802	21	488.6	461.4	950	1214
0.5207	0.3825	22	499.7	460	959.6	1202
0.5268	0.3846	23	510.4	458.4	968.8	1192
0.5328	0.3865	24	520.8	456.6	977.4	1181

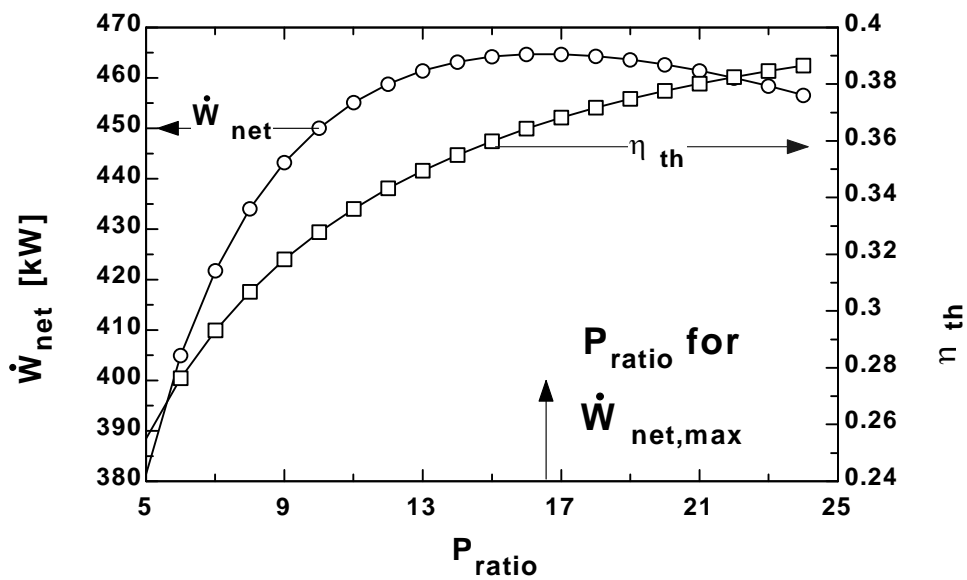

9-194 EES The effects of pressure ratio, maximum cycle temperature, and compressor and turbine inefficiencies on the net work output per unit mass and the thermal efficiency of a simple Brayton cycle with air as the working fluid is to be investigated. Constant specific heats at room temperature are to be used.

Analysis Using EES, the problem is solved as follows:

```
Procedure ConstPropResult(T[1],P[1],r_comp,T[3]:Eta_th_ConstProp,Eta_th_easy)
```

```
"For Air:"
```

```
C_V = 0.718 [kJ/kg-K]
```

```
k = 1.4
```

```
T2 = T[1]*r_comp^(k-1)
```

```
P2 = P[1]*r_comp^k
```

```
q_in_23 = C_V*(T[3]-T2)
```

```
T4 = T[3]*(1/r_comp)^(k-1)
```

```
q_out_41 = C_V*(T4-T[1])
```

```
Eta_th_ConstProp = (1-q_out_41/q_in_23)*Convert(, %) "[%]"
```

```
"The Easy Way to calculate the constant property Otto cycle efficiency is:"
```

```
Eta_th_easy = (1 - 1/r_comp^(k-1))*Convert(, %) "[%]"
```

```
END
```

```
"Input Data"
```

```
T[1]=300 [K]
```

```
P[1]=100 [kPa]
```

```
{T[3] = 1000 [K]}
```

```
r_comp = 12
```

```
"Process 1-2 is isentropic compression"
```

```
s[1]=entropy(air,T=T[1],P=P[1])
```

```
s[2]=s[1]
```

```
T[2]=temperature(air, s=s[2], P=P[2])
```

```
P[2]*v[2]/T[2]=P[1]*v[1]/T[1]
```

```
P[1]*v[1]=R*T[1]
```

```
R=0.287 [kJ/kg-K]
```

```
V[2] = V[1]/ r_comp
```

```
"Conservation of energy for process 1 to 2"
```

```
q_12 - w_12 = DELTAu_12
```

```
q_12 = 0 "isentropic process"
```

```
DELTAu_12=intenergy(air,T=T[2])-intenergy(air,T=T[1])
```

```
"Process 2-3 is constant volume heat addition"
```

```
v[3]=v[2]
```

```
s[3]=entropy(air, T=T[3], P=P[3])
```

```
P[3]*v[3]=R*T[3]
```

```
"Conservation of energy for process 2 to 3"
```

```
q_23 - w_23 = DELTAu_23
```

```
w_23 = 0 "constant volume process"
```

```
DELTAu_23=intenergy(air,T=T[3])-intenergy(air,T=T[2])
```

```
"Process 3-4 is isentropic expansion"
```

```
s[4]=s[3]
```

```
s[4]=entropy(air,T=T[4],P=P[4])
```

```
P[4]*v[4]=R*T[4]
```

```
"Conservation of energy for process 3 to 4"
```

```
q_34 - w_34 = DELTAu_34
```

```
q_34 = 0 "isentropic process"
```

```
DELTAu_34=intenergy(air,T=T[4])-intenergy(air,T=T[3])
```

"Process 4-1 is constant volume heat rejection"

$$V[4] = V[1]$$

"Conservation of energy for process 4 to 1"

$$q_{41} - w_{41} = \Delta U_{41}$$

$$w_{41} = 0 \text{ "constant volume process"}$$

$$\Delta U_{41} = \text{intenergy}(\text{air}, T=T[1]) - \text{intenergy}(\text{air}, T=T[4])$$

$$q_{\text{in_total}} = q_{23}$$

$$q_{\text{out_total}} = -q_{41}$$

$$w_{\text{net}} = w_{12} + w_{23} + w_{34} + w_{41}$$

$$\eta_{\text{th}} = w_{\text{net}} / q_{\text{in_total}} \cdot \text{Convert}(\%, \text{ "Thermal efficiency, in percent"}$$

Call ConstPropResult(T[1], P[1], r_comp, T[3]: Eta_th_ConstProp, Eta_th_easy)

$$\text{PerCentError} = \text{ABS}(\eta_{\text{th}} - \eta_{\text{th_ConstProp}}) / \eta_{\text{th}} \cdot \text{Convert}(\%, \text{ "[%]"})$$

PerCentError [%]	r_{comp}	η_{th} [%]	$\eta_{\text{th,ConstProp}}$ [%]	$\eta_{\text{th,easy}}$ [%]	T_3 [K]
3.604	12	60.8	62.99	62.99	1000
6.681	12	59.04	62.99	62.99	1500
9.421	12	57.57	62.99	62.99	2000
11.64	12	56.42	62.99	62.99	2500

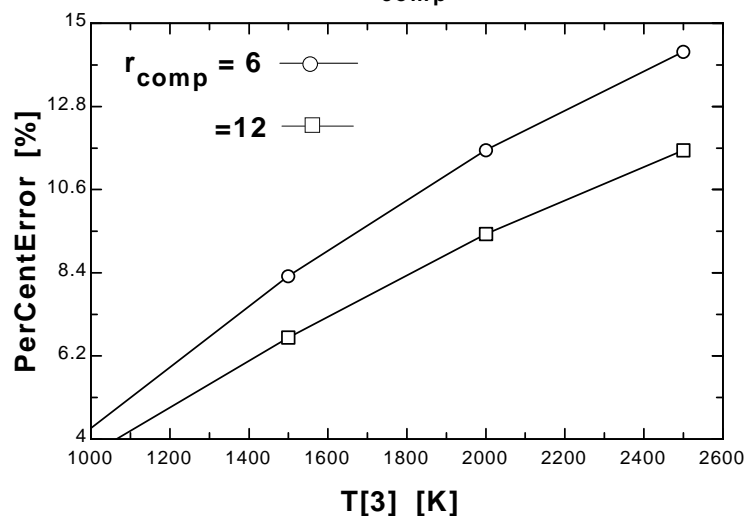
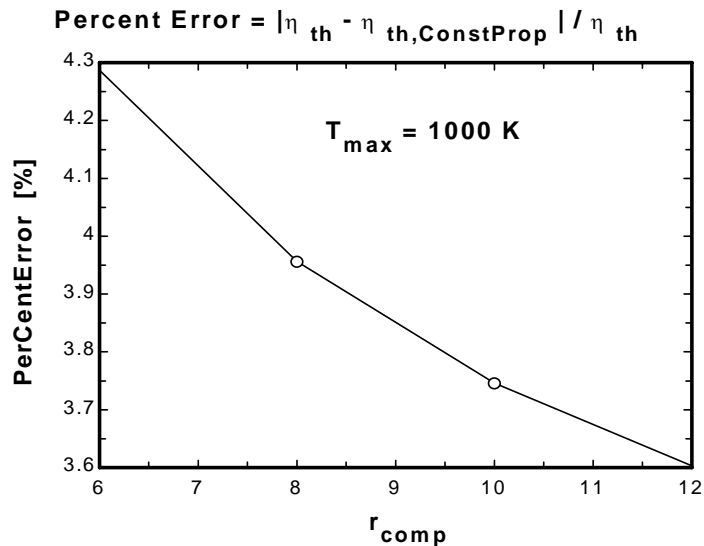

9-195 EES The effects of pressure ratio, maximum cycle temperature, and compressor and turbine efficiencies on the net work output per unit mass and the thermal efficiency of a simple Brayton cycle with air as the working fluid is to be investigated. Variable specific heats are to be used.

Analysis Using EES, the problem is solved as follows:

"Input data - from diagram window"

```
{P_ratio = 8}
{T[1] = 300 [K]
P[1]= 100 [kPa]
T[3] = 800 [K]
m_dot = 1 [kg/s]
Eta_c = 75/100
Eta_t = 82/100}
```

"Inlet conditions"

```
h[1]=ENTHALPY(Air,T=T[1])
s[1]=ENTROPY(Air,T=T[1],P=P[1])
```

"Compressor analysis"

```
s_s[2]=s[1] "For the ideal case the entropies are constant across the compressor"
P_ratio=P[2]/P[1]"Definition of pressure ratio - to find P[2]"
T_s[2]=TEMPERATURE(Air,s=s_s[2],P=P[2]) "T_s[2] is the isentropic value of T[2] at
compressor exit"
h_s[2]=ENTHALPY(Air,T=T_s[2])
Eta_c =(h_s[2]-h[1])/(h[2]-h[1]) "Compressor adiabatic efficiency; Eta_c =
W_dot_c_ideal/W_dot_c_actual. "
m_dot*h[1] +W_dot_c=m_dot*h[2] "SSSF First Law for the actual compressor, assuming:
adiabatic, ke=pe=0"
```

"External heat exchanger analysis"

```
P[3]=P[2]"process 2-3 is SSSF constant pressure"
h[3]=ENTHALPY(Air,T=T[3])
m_dot*h[2] + Q_dot_in= m_dot*h[3]"SSSF First Law for the heat exchanger, assuming W=0,
ke=pe=0"
```

"Turbine analysis"

```
s[3]=ENTROPY(Air,T=T[3],P=P[3])
s_s[4]=s[3] "For the ideal case the entropies are constant across the turbine"
P_ratio= P[3] /P[4]
T_s[4]=TEMPERATURE(Air,s=s_s[4],P=P[4]) "Ts[4] is the isentropic value of T[4] at turbine exit"
h_s[4]=ENTHALPY(Air,T=T_s[4]) "Eta_t = W_dot_t /Wts_dot turbine adiabatic efficiency,
Wts_dot > W_dot_t"
Eta_t=(h[3]-h[4])/(h[3]-h_s[4])
m_dot*h[3] = W_dot_t + m_dot*h[4] "SSSF First Law for the actual compressor, assuming:
adiabatic, ke=pe=0"
```

"Cycle analysis"

```
W_dot_net=W_dot_t-W_dot_c"Definition of the net cycle work, kW"
Eta=W_dot_net/Q_dot_in"Cycle thermal efficiency"
Bwr=W_dot_c/W_dot_t "Back work ratio"
"The following state points are determined only to produce a T-s plot"
T[2]=temperature('air',h=h[2])
T[4]=temperature('air',h=h[4])
s[2]=entropy('air',T=T[2],P=P[2])
s[4]=entropy('air',T=T[4],P=P[4])
```

Bwr	η	P_{ratio}	W_c [kW]	W_{net} [kW]	W_t [kW]	Q_{in} [kW]
0.5229	0.1	2	1818	1659	3477	16587
0.6305	0.1644	4	4033	2364	6396	14373
0.7038	0.1814	6	5543	2333	7876	12862
0.7611	0.1806	8	6723	2110	8833	11682
0.8088	0.1702	10	7705	1822	9527	10700
0.85	0.1533	12	8553	1510	10063	9852
0.8864	0.131	14	9304	1192	10496	9102
0.9192	0.1041	16	9980	877.2	10857	8426
0.9491	0.07272	18	10596	567.9	11164	7809
0.9767	0.03675	20	11165	266.1	11431	7241

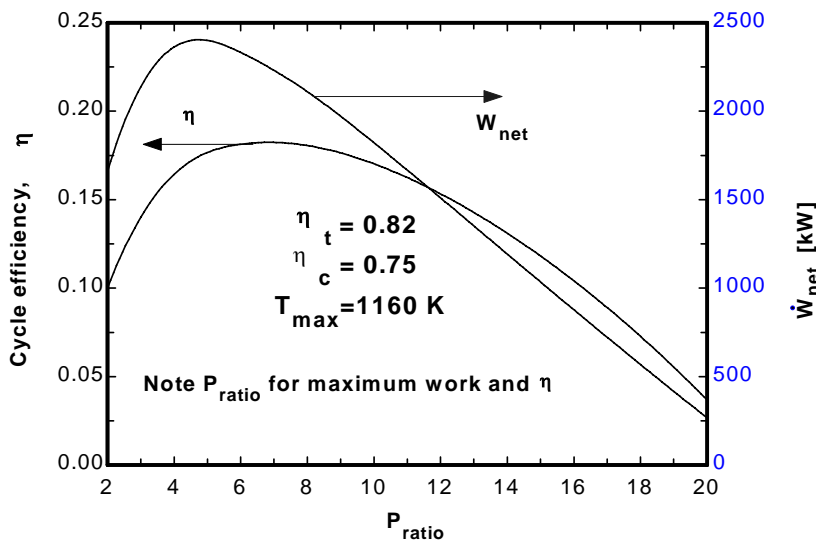
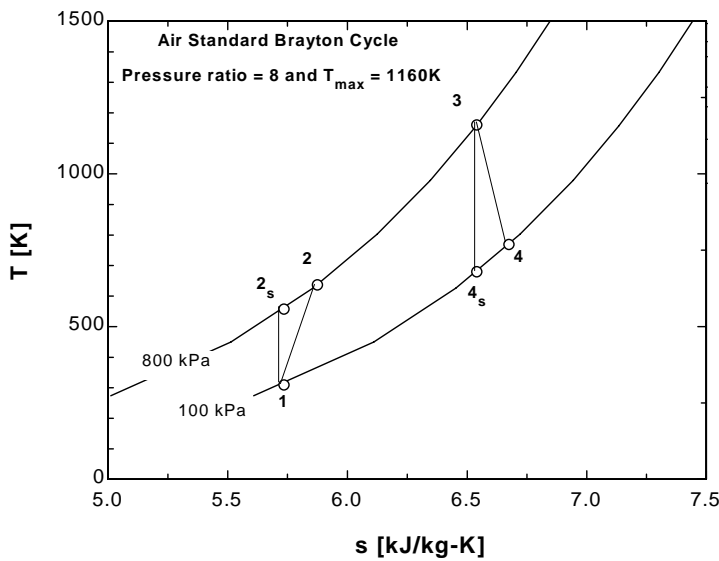

9-196 EES The effects of pressure ratio, maximum cycle temperature, and compressor and turbine efficiencies on the net work output per unit mass and the thermal efficiency of a simple Brayton cycle with helium as the working fluid is to be investigated.

Analysis Using EES, the problem is solved as follows:

```
Function hFunc(WorkFluid$,T,P)
"The EES functions treat helium as a real gas; thus, T and P are needed for helium's enthalpy."
IF WorkFluid$ = 'Air' then hFunc:=enthalpy(Air,T=T) ELSE
    hFunc: = enthalpy(Helium,T=T,P=P)
endif
END
Procedure EtaCheck(Eta_th:EtaError$)
If Eta_th < 0 then EtaError$ = 'Why are the net work done and efficiency < 0?' Else EtaError$ = ""
END
"Input data - from diagram window"
{P_ratio = 8}
{T[1] = 300 [K]}
{P[1]= 100 [kPa]}
{T[3] = 800 [K]}
{m_dot = 1 [kg/s]}
{Eta_c = 0.8}
{Eta_t = 0.8}
WorkFluid$ = 'Helium'}
"Inlet conditions"
h[1]=hFunc(WorkFluid$,T[1],P[1])
s[1]=ENTROPY(WorkFluid$,T=T[1],P=P[1])
"Compressor analysis"
s_s[2]=s[1] "For the ideal case the entropies are constant across the compressor"
P_ratio=P[2]/P[1]"Definition of pressure ratio - to find P[2]"
T_s[2]=TEMPERATURE(WorkFluid$,s=s_s[2],P=P[2]) "T_s[2] is the isentropic value of T[2] at
compressor exit"
h_s[2]=hFunc(WorkFluid$,T_s[2],P[2])
Eta_c =(h_s[2]-h[1])/(h[2]-h[1]) "Compressor adiabatic efficiency; Eta_c =
W_dot_c_ideal/W_dot_c_actual. "
m_dot*h[1] +W_dot_c=m_dot*h[2] "SSSF First Law for the actual compressor, assuming:
adiabatic, ke=pe=0"
"External heat exchanger analysis"
P[3]=P[2]"process 2-3 is SSSF constant pressure"
h[3]=hFunc(WorkFluid$,T[3],P[3])
m_dot*h[2] + Q_dot_in= m_dot*h[3]"SSSF First Law for the heat exchanger, assuming W=0,
ke=pe=0"
"Turbine analysis"
s[3]=ENTROPY(WorkFluid$,T=T[3],P=P[3])
s_s[4]=s[3] "For the ideal case the entropies are constant across the turbine"
P_ratio= P[3] /P[4]
T_s[4]=TEMPERATURE(WorkFluid$,s=s_s[4],P=P[4]) "Ts[4] is the isentropic value of T[4] at
turbine exit"
h_s[4]=hFunc(WorkFluid$,T_s[4],P[4]) "Eta_t = W_dot_t /Wts_dot turbine adiabatic efficiency,
Wts_dot > W_dot_t"
Eta_t=(h[3]-h[4])/(h[3]-h_s[4])
m_dot*h[3] = W_dot_t + m_dot*h[4] "SSSF First Law for the actual compressor, assuming:
adiabatic, ke=pe=0"
"Cycle analysis"
W_dot_net=W_dot_t-W_dot_c"Definition of the net cycle work, kW"
```

$\text{Eta_th} = W_{\text{dot_net}} / Q_{\text{dot_in}}$ "Cycle thermal efficiency"

Call EtaCheck(Eta_th:EtaError\$)

$\text{Bwr} = W_{\text{dot_c}} / W_{\text{dot_t}}$ "Back work ratio"

"The following state points are determined only to produce a T-s plot"

$T[2] = \text{temperature}(\text{'air'}, h=h[2])$

$T[4] = \text{temperature}(\text{'air'}, h=h[4])$

$s[2] = \text{entropy}(\text{'air'}, T=T[2], P=P[2])$

$s[4] = \text{entropy}(\text{'air'}, T=T[4], P=P[4])$

Bwr	η	P_{ratio}	W_c [kW]	W_{net} [kW]	W_t [kW]	Q_{in} [kW]
0.5229	0.1	2	1818	1659	3477	16587
0.6305	0.1644	4	4033	2364	6396	14373
0.7038	0.1814	6	5543	2333	7876	12862
0.7611	0.1806	8	6723	2110	8833	11682
0.8088	0.1702	10	7705	1822	9527	10700
0.85	0.1533	12	8553	1510	10063	9852
0.8864	0.131	14	9304	1192	10496	9102
0.9192	0.1041	16	9980	877.2	10857	8426
0.9491	0.07272	18	10596	567.9	11164	7809
0.9767	0.03675	20	11165	266.1	11431	7241

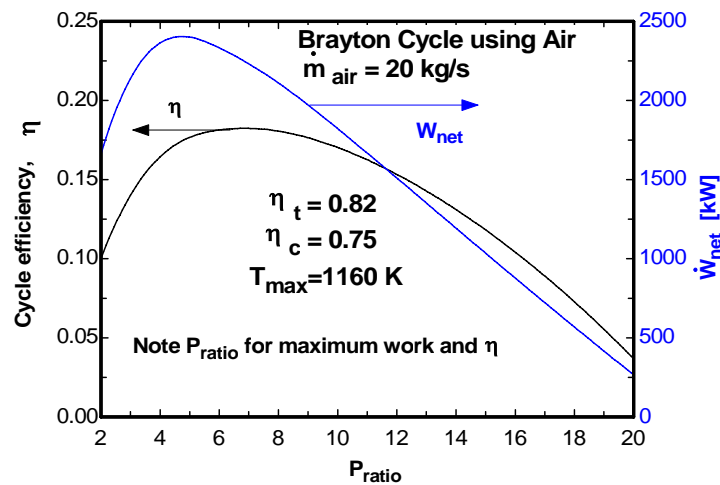
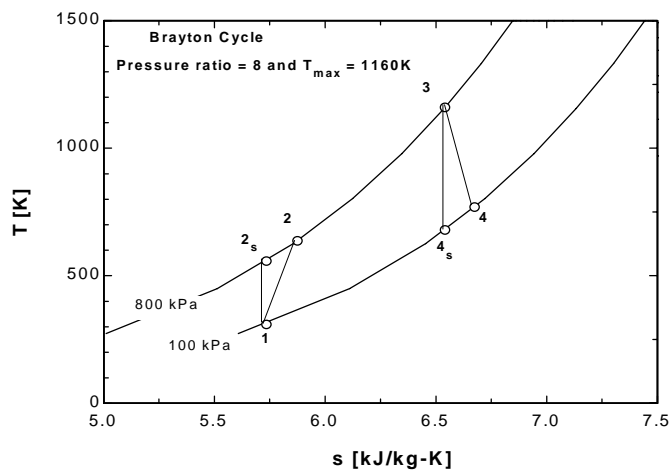

9-197 EES The effect of the number of compression and expansion stages on the thermal efficiency of an ideal regenerative Brayton cycle with multistage compression and expansion and air as the working fluid is to be investigated.

Analysis Using EES, the problem is solved as follows:

"Input data for air"

$C_P = 1.005$ [kJ/kg-K]

$k = 1.4$

"Nstages is the number of compression and expansion stages"

$N_{stages} = 1$

$T_6 = 1200$ [K]

$Pratio = 12$

$T_1 = 300$ [K]

$P_1 = 100$ [kPa]

$Eta_{reg} = 1.0$ "regenerator effectiveness"

$Eta_c = 1.0$ "Compressor isentropic efficiency"

$Eta_t = 1.0$ "Turbine isentropic efficiency"

$R_p = Pratio^{(1/N_{stages})}$

"Isentropic Compressor analysis"

$T_{2s} = T_1 * R_p^{((k-1)/k)}$

$P_2 = R_p * P_1$

" T_{2s} is the isentropic value of T_2 at compressor exit"

$Eta_c = w_{compisen} / w_{comp}$

"compressor adiabatic efficiency, $W_{comp} > W_{compisen}$ "

"Conservation of energy for the compressor for the isentropic case:

$e_{in} - e_{out} = \Delta e = 0$ for steady-flow"

$w_{compisen} = C_P * (T_{2s} - T_1)$

"Actual compressor analysis:"

$w_{comp} = C_P * (T_2 - T_1)$

"Since intercooling is assumed to occur such that $T_3 = T_1$ and the compressors have the same pressure ratio, the work input to each compressor is the same. The total compressor work is:"

$w_{comp_total} = N_{stages} * w_{comp}$

"External heat exchanger analysis"

"SSSF First Law for the heat exchanger, assuming $W=0$, $ke=pe=0$

$e_{in} - e_{out} = \Delta e_{cv} = 0$ for steady flow"

"The heat added in the external heat exchanger + the reheat between turbines is"

$q_{in_total} = C_P * (T_6 - T_5) + (N_{stages} - 1) * C_P * (T_8 - T_7)$

"Reheat is assumed to occur until:"

$T_8 = T_6$

"Turbine analysis"

$P_7 = P_6 / R_p$

" T_{7s} is the isentropic value of T_7 at turbine exit"

$T_{7s} = T_6 * (1/R_p)^{((k-1)/k)}$

"Turbine adiabatic efficiency, $w_{turbisen} > w_{turb}$ "

$Eta_t = w_{turb} / w_{turbisen}$

"SSSF First Law for the isentropic turbine, assuming: adiabatic, $ke=pe=0$

$e_{in} - e_{out} = \Delta e_{cv} = 0$ for steady-flow"

$w_{turbisen} = C_P * (T_6 - T_{7s})$

"Actual Turbine analysis:"

$w_{turb} = C_P * (T_6 - T_7)$

$w_{turb_total} = N_{stages} * w_{turb}$

"Cycle analysis"

$w_{net} = w_{turb_total} - w_{comp_total}$ "[kJ/kg]"

$Bwr = w_{comp} / w_{turb}$ "Back work ratio"

$P_4 = P_2$

$P_5 = P_4$

$P_6 = P_5$

$T_4 = T_2$

"The regenerator effectiveness gives T_5 as:"

$\eta_{reg} = (T_5 - T_4) / (T_9 - T_4)$

$T_9 = T_7$

"Energy balance on regenerator gives T_{10} as:"

$T_4 + T_9 = T_5 + T_{10}$

"Cycle thermal efficiency with regenerator"

$\eta_{th_regenerative} = w_{net} / q_{in_total} * \text{Convert}(, \%)$ "[%]"

"The efficiency of the Ericsson cycle is the same as the Carnot cycle operating between the same max and min temperatures, T_6 and T_1 for this problem."

$\eta_{th_Ericsson} = (1 - T_1 / T_6) * \text{Convert}(, \%)$ "[%]"

$\eta_{th, Ericsson}$ [%]	$\eta_{th, Regenerative}$ [%]	Nstages
75	49.15	1
75	64.35	2
75	68.32	3
75	70.14	4
75	72.33	7
75	73.79	15
75	74.05	19
75	74.18	22

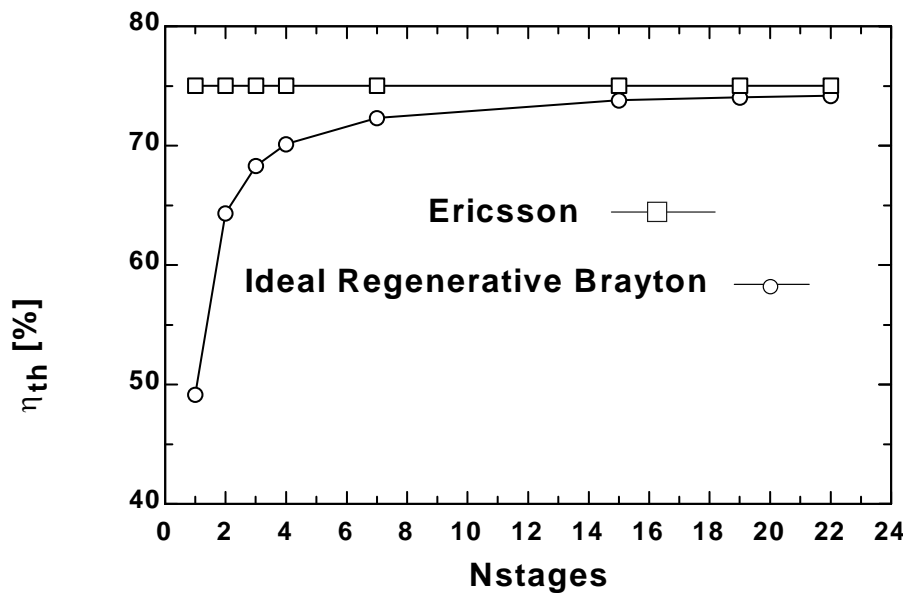

9-198 EES The effect of the number of compression and expansion stages on the thermal efficiency of an ideal regenerative Brayton cycle with multistage compression and expansion and helium as the working fluid is to be investigated.

Analysis Using EES, the problem is solved as follows:

"Input data for Helium"

$C_P = 5.1926$ [kJ/kg-K]

$k = 1.667$

"Nstages is the number of compression and expansion stages"

{Nstages = 1}

$T_6 = 1200$ [K]

Pratio = 12

$T_1 = 300$ [K]

$P_1 = 100$ [kPa]

$\text{Eta}_{\text{reg}} = 1.0$ "regenerator effectiveness"

$\text{Eta}_{\text{c}} = 1.0$ "Compressor isentropic efficiency"

$\text{Eta}_{\text{t}} = 1.0$ "Turbine isentropic efficiency"

$R_p = \text{Pratio}^{(1/\text{Nstages})}$

"Isentropic Compressor analysis"

$T_{2s} = T_1 * R_p^{((k-1)/k)}$

$P_2 = R_p * P_1$

" T_{2s} is the isentropic value of T_2 at compressor exit"

$\text{Eta}_{\text{c}} = w_{\text{compisen}}/w_{\text{comp}}$

"compressor adiabatic efficiency, $W_{\text{comp}} > W_{\text{compisen}}$ "

"Conservation of energy for the compressor for the isentropic case:

$e_{\text{in}} - e_{\text{out}} = \text{DELTA}e = 0$ for steady-flow"

$w_{\text{compisen}} = C_P * (T_{2s} - T_1)$

"Actual compressor analysis:"

$w_{\text{comp}} = C_P * (T_2 - T_1)$

"Since intercooling is assumed to occur such that $T_3 = T_1$ and the compressors have the same pressure ratio, the work input to each compressor is the same. The total compressor work is:"

$w_{\text{comp_total}} = \text{Nstages} * w_{\text{comp}}$

"External heat exchanger analysis"

"SSSF First Law for the heat exchanger, assuming $W=0$, $ke=pe=0$

$e_{\text{in}} - e_{\text{out}} = \text{DELTA}e_{\text{cv}} = 0$ for steady flow"

"The heat added in the external heat exchanger + the reheat between turbines is"

$q_{\text{in_total}} = C_P * (T_6 - T_5) + (\text{Nstages} - 1) * C_P * (T_8 - T_7)$

"Reheat is assumed to occur until:"

$T_8 = T_6$

"Turbine analysis"

$P_7 = P_6 / R_p$

" T_{7s} is the isentropic value of T_7 at turbine exit"

$T_{7s} = T_6 * (1/R_p)^{((k-1)/k)}$

"Turbine adiabatic efficiency, $w_{\text{turbisen}} > w_{\text{turb}}$ "

$\text{Eta}_{\text{t}} = w_{\text{turb}}/w_{\text{turbisen}}$

"SSSF First Law for the isentropic turbine, assuming: adiabatic, $ke=pe=0$

$e_{\text{in}} - e_{\text{out}} = \text{DELTA}e_{\text{cv}} = 0$ for steady-flow"

$w_{\text{turbisen}} = C_P * (T_6 - T_{7s})$

"Actual Turbine analysis:"

$w_{\text{turb}} = C_P * (T_6 - T_7)$

$w_{\text{turb_total}} = \text{Nstages} * w_{\text{turb}}$

"Cycle analysis"

$w_{net} = w_{turb_total} - w_{comp_total}$

$Bwr = w_{comp} / w_{turb}$ "Back work ratio"

$P_4 = P_2$

$P_5 = P_4$

$P_6 = P_5$

$T_4 = T_2$

"The regenerator effectiveness gives T_5 as:"

$\eta_{reg} = (T_5 - T_4) / (T_9 - T_4)$

$T_9 = T_7$

"Energy balance on regenerator gives T_{10} as:"

$T_4 + T_9 = T_5 + T_{10}$

"Cycle thermal efficiency with regenerator"

$\eta_{th_regenerative} = w_{net} / q_{in_total} * \text{Convert}(, \%)$ "[%]"

"The efficiency of the Ericsson cycle is the same as the Carnot cycle operating between the same max and min temperatures, T_6 and T_1 for this problem."

$\eta_{th_Ericsson} = (1 - T_1 / T_6) * \text{Convert}(, \%)$ "[%]"

$\eta_{th, Ericsson}$ [%]	$\eta_{th, Regenerative}$ [%]	Nstages
75	32.43	1
75	58.9	2
75	65.18	3
75	67.95	4
75	71.18	7
75	73.29	15
75	73.66	19
75	73.84	22

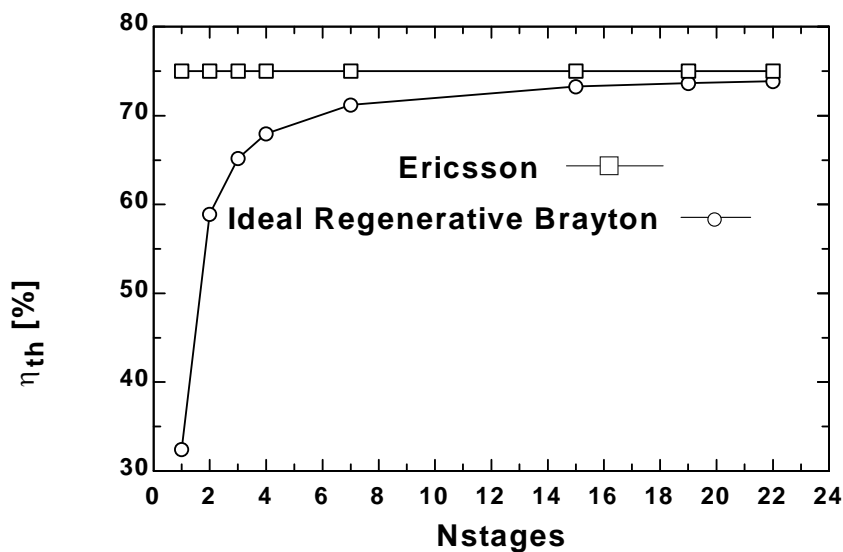

Fundamentals of Engineering (FE) Exam Problems

9-199 An Otto cycle with air as the working fluid has a compression ratio of 8.2. Under cold air standard conditions, the thermal efficiency of this cycle is

- (a) 24% (b) 43% (c) 52% (d) 57% (e) 75%

Answer (d) 57%

Solution Solved by EES Software. Solutions can be verified by copying-and-pasting the following lines on a blank EES screen. (Similar problems and their solutions can be obtained easily by modifying numerical values).

```
r=8.2
k=1.4
Eta_Otto=1-1/r^(k-1)
```

"Some Wrong Solutions with Common Mistakes:"

```
W1_Eta = 1/r "Taking efficiency to be 1/r"
W2_Eta = 1/r^(k-1) "Using incorrect relation"
W3_Eta = 1-1/r^(k1-1); k1=1.667 "Using wrong k value"
```

9-200 For specified limits for the maximum and minimum temperatures, the ideal cycle with the lowest thermal efficiency is

- (a) Carnot (b) Stirling (c) Ericsson (d) Otto (e) All are the same

Answer (d) Otto

9-201 A Carnot cycle operates between the temperatures limits of 300 K and 2000 K, and produces 600 kW of net power. The rate of entropy change of the working fluid during the heat addition process is

- (a) 0 (b) 0.300 kW/K (c) 0.353 kW/K (d) 0.261 kW/K (e) 2.0 kW/K

Answer (c) 0.353 kW/K

Solution Solved by EES Software. Solutions can be verified by copying-and-pasting the following lines on a blank EES screen. (Similar problems and their solutions can be obtained easily by modifying numerical values).

```
TL=300 "K"
TH=2000 "K"
Wnet=600 "kJ/s"
Wnet= (TH-TL)*DS
```

"Some Wrong Solutions with Common Mistakes:"

```
W1_DS = Wnet/TH "Using TH instead of TH-TL"
W2_DS = Wnet/TL "Using TL instead of TH-TL"
W3_DS = Wnet/(TH+TL) "Using TH+TL instead of TH-TL"
```

9-202 Air in an ideal Diesel cycle is compressed from 3 L to 0.15 L, and then it expands during the constant pressure heat addition process to 0.30 L. Under cold air standard conditions, the thermal efficiency of this cycle is

- (a) 35% (b) 44% (c) 65% (d) 70% (e) 82%

Answer (c) 65%

Solution Solved by EES Software. Solutions can be verified by copying-and-pasting the following lines on a blank EES screen. (Similar problems and their solutions can be obtained easily by modifying numerical values).

```
V1=3 "L"
V2= 0.15 "L"
V3= 0.30 "L"
r=V1/V2
rc=V3/V2
k=1.4
Eta_Diesel=1-(1/r^(k-1))*(rc^k-1)/k/(rc-1)
```

"Some Wrong Solutions with Common Mistakes:"

```
W1_Eta = 1-(1/r1^(k-1))*(rc^k-1)/k/(rc-1); r1=V1/V3 "Wrong r value"
W2_Eta = 1-Eta_Diesel "Using incorrect relation"
W3_Eta = 1-(1/r^(k1-1))*(rc^k1-1)/k1/(rc-1); k1=1.667 "Using wrong k value"
W4_Eta = 1-1/r^(k-1) "Using Otto cycle efficiency"
```

9-203 Helium gas in an ideal Otto cycle is compressed from 20°C and 2.5 L to 0.25 L, and its temperature increases by an additional 700°C during the heat addition process. The temperature of helium before the expansion process is

- (a) 1790°C (b) 2060°C (c) 1240°C (d) 620°C (e) 820°C

Answer (a) 1790°C

Solution Solved by EES Software. Solutions can be verified by copying-and-pasting the following lines on a blank EES screen. (Similar problems and their solutions can be obtained easily by modifying numerical values).

```
k=1.667
V1=2.5
V2=0.25
r=V1/V2
T1=20+273 "K"
T2=T1*r^(k-1)
T3=T2+700-273 "C"
```

"Some Wrong Solutions with Common Mistakes:"

```
W1_T3 = T22+700-273; T22=T1*r^(k1-1); k1=1.4 "Using wrong k value"
W2_T3 = T3+273 "Using K instead of C"
W3_T3 = T1+700-273 "Disregarding temp rise during compression"
W4_T3 = T222+700-273; T222=(T1-273)*r^(k-1) "Using C for T1 instead of K"
```

9-204 In an ideal Otto cycle, air is compressed from 1.20 kg/m^3 and 2.2 L to 0.26 L , and the net work output of the cycle is 440 kJ/kg . The mean effective pressure (MEP) for this cycle is

- (a) 612 kPa (b) 599 kPa (c) 528 kPa (d) 416 kPa (e) 367 kPa

Answer (b) 599 kPa

Solution Solved by EES Software. Solutions can be verified by copying-and-pasting the following lines on a blank EES screen. (Similar problems and their solutions can be obtained easily by modifying numerical values).

```
rho1=1.20 "kg/m^3"
k=1.4
V1=2.2
V2=0.26
m=rho1*V1/1000 "kg"
w_net=440 "kJ/kg"
Wtotal=m*w_net
MEP=Wtotal/((V1-V2)/1000)
```

"Some Wrong Solutions with Common Mistakes:"

```
W1_MEP = w_net/((V1-V2)/1000) "Disregarding mass"
W2_MEP = Wtotal/(V1/1000) "Using V1 instead of V1-V2"
W3_MEP = (rho1*V2/1000)*w_net/((V1-V2)/1000); "Finding mass using V2 instead of V1"
W4_MEP = Wtotal/((V1+V2)/1000) "Adding V1 and V2 instead of subtracting"
```

9-205 In an ideal Brayton cycle, air is compressed from 95 kPa and 25°C to 800 kPa . Under cold air standard conditions, the thermal efficiency of this cycle is

- (a) 46% (b) 54% (c) 57% (d) 39% (e) 61%

Answer (a) 46%

Solution Solved by EES Software. Solutions can be verified by copying-and-pasting the following lines on a blank EES screen. (Similar problems and their solutions can be obtained easily by modifying numerical values).

```
P1=95 "kPa"
P2=800 "kPa"
T1=25+273 "K"
rp=P2/P1
k=1.4
Eta_Brayton=1-1/rp^((k-1)/k)
```

"Some Wrong Solutions with Common Mistakes:"

```
W1_Eta = 1/rp "Taking efficiency to be 1/rp"
W2_Eta = 1/rp^((k-1)/k) "Using incorrect relation"
W3_Eta = 1-1/rp^((k1-1)/k1); k1=1.667 "Using wrong k value"
```

9-206 Consider an ideal Brayton cycle executed between the pressure limits of 1200 kPa and 100 kPa and temperature limits of 20°C and 1000°C with argon as the working fluid. The net work output of the cycle is

- (a) 68 kJ/kg (b) 93 kJ/kg (c) 158 kJ/kg (d) 186 kJ/kg (e) 310 kJ/kg

Answer (c) 158 kJ/kg

Solution Solved by EES Software. Solutions can be verified by copying-and-pasting the following lines on a blank EES screen. (Similar problems and their solutions can be obtained easily by modifying numerical values).

```
P1=100 "kPa"
P2=1200 "kPa"
T1=20+273 "K"
T3=1000+273 "K"
rp=P2/P1
k=1.667
Cp=0.5203 "kJ/kg.K"
Cv=0.3122 "kJ/kg.K"
T2=T1*rp^((k-1)/k)
q_in=Cp*(T3-T2)
Eta_Brayton=1-1/rp^((k-1)/k)
w_net=Eta_Brayton*q_in
```

"Some Wrong Solutions with Common Mistakes:"

```
W1_wnet = (1-1/rp^((k-1)/k))*qin1; qin1=Cv*(T3-T2) "Using Cv instead of Cp"
W2_wnet = (1-1/rp^((k-1)/k))*qin2; qin2=1.005*(T3-T2) "Using Cp of air instead of argon"
W3_wnet = (1-1/rp^((k1-1)/k1))*Cp*(T3-T22); T22=T1*rp^((k1-1)/k1); k1=1.4 "Using k of air instead of argon"
W4_wnet = (1-1/rp^((k-1)/k))*Cp*(T3-T222); T222=(T1-273)*rp^((k-1)/k) "Using C for T1 instead of K"
```

9-207 An ideal Brayton cycle has a net work output of 150 kJ/kg and a backwork ratio of 0.4. If both the turbine and the compressor had an isentropic efficiency of 85%, the net work output of the cycle would be

- (a) 74 kJ/kg (b) 95 kJ/kg (c) 109 kJ/kg (d) 128 kJ/kg (e) 177 kJ/kg

Answer (b) 95 kJ/kg

Solution Solved by EES Software. Solutions can be verified by copying-and-pasting the following lines on a blank EES screen. (Similar problems and their solutions can be obtained easily by modifying numerical values).

```
wcomp/wturb=0.4
wturb-wcomp=150 "kJ/kg"
Eff=0.85
w_net=Eff*wturb-wcomp/Eff
```

"Some Wrong Solutions with Common Mistakes:"

```
W1_wnet = Eff*wturb-wcomp*Eff "Making a mistake in Wnet relation"
W2_wnet = (wturb-wcomp)/Eff "Using a wrong relation"
W3_wnet = wturb/eff-wcomp*Eff "Using a wrong relation"
```

9-208 In an ideal Brayton cycle, air is compressed from 100 kPa and 25°C to 1 MPa, and then heated to 1200°C before entering the turbine. Under cold air standard conditions, the air temperature at the turbine exit is

- (a) 490°C (b) 515°C (c) 622°C (d) 763°C (e) 895°C

Answer (a) 490°C

Solution Solved by EES Software. Solutions can be verified by copying-and-pasting the following lines on a blank EES screen. (Similar problems and their solutions can be obtained easily by modifying numerical values).

```
P1=100 "kPa"
P2=1000 "kPa"
T1=25+273 "K"
T3=1200+273 "K"
rp=P2/P1
k=1.4
T4=T3*(1/rp)^((k-1)/k)-273
```

"Some Wrong Solutions with Common Mistakes:"

```
W1_T4 = T3/rp "Using wrong relation"
W2_T4 = (T3-273)/rp "Using wrong relation"
W3_T4 = T4+273 "Using K instead of C"
W4_T4 = T1+800-273 "Disregarding temp rise during compression"
```

9-209 In an ideal Brayton cycle with regeneration, argon gas is compressed from 100 kPa and 25°C to 400 kPa, and then heated to 1200°C before entering the turbine. The highest temperature that argon can be heated in the regenerator is

- (a) 246°C (b) 846°C (c) 689°C (d) 368°C (e) 573°C

Answer (e) 573°C

Solution Solved by EES Software. Solutions can be verified by copying-and-pasting the following lines on a blank EES screen. (Similar problems and their solutions can be obtained easily by modifying numerical values).

```
k=1.667
Cp=0.5203 "kJ/kg.K"
P1=100 "kPa"
P2=400 "kPa"
T1=25+273 "K"
T3=1200+273 "K"
"The highest temperature that argon can be heated in the regenerator is the turbine exit
temperature,"
rp=P2/P1
T2=T1*rp^((k-1)/k)
T4=T3/rp^((k-1)/k)-273
```

"Some Wrong Solutions with Common Mistakes:"

```
W1_T4 = T3/rp "Using wrong relation"
W2_T4 = (T3-273)/rp^((k-1)/k) "Using C instead of K for T3"
W3_T4 = T4+273 "Using K instead of C"
W4_T4 = T2-273 "Taking compressor exit temp as the answer"
```

9-210 In an ideal Brayton cycle with regeneration, air is compressed from 80 kPa and 10°C to 400 kPa and 175°C, is heated to 450°C in the regenerator, and then further heated to 1000°C before entering the turbine. Under cold air standard conditions, the effectiveness of the regenerator is

- (a) 33% (b) 44% (c) 62% (d) 77% (e) 89%

Answer (d) 77%

Solution Solved by EES Software. Solutions can be verified by copying-and-pasting the following lines on a blank EES screen. (Similar problems and their solutions can be obtained easily by modifying numerical values).

```

k=1.4
Cp=1.005 "kJ/kg.K"
P1=80 "kPa"
P2=400 "kPa"
T1=10+273 "K"
T2=175+273 "K"
T3=1000+273 "K"
T5=450+273 "K"
"The highest temperature that the gas can be heated in the regenerator is the turbine exit
temperature,"
rp=P2/P1
T2check=T1*rp^((k-1)/k) "Checking the given value of T2. It checks."
T4=T3/rp^((k-1)/k)
Effective=(T5-T2)/(T4-T2)

```

"Some Wrong Solutions with Common Mistakes:"

```

W1_eff = (T5-T2)/(T3-T2) "Using wrong relation"
W2_eff = (T5-T2)/(T44-T2); T44=(T3-273)/rp^((k-1)/k) "Using C instead of K for T3"
W3_eff = (T5-T2)/(T444-T2); T444=T3/rp "Using wrong relation for T4"

```

9-211 Consider a gas turbine that has a pressure ratio of 6 and operates on the Brayton cycle with regeneration between the temperature limits of 20°C and 900°C. If the specific heat ratio of the working fluid is 1.3, the highest thermal efficiency this gas turbine can have is

- (a) 38% (b) 46% (c) 62% (d) 58% (e) 97%

Answer (c) 62%

Solution Solved by EES Software. Solutions can be verified by copying-and-pasting the following lines on a blank EES screen. (Similar problems and their solutions can be obtained easily by modifying numerical values).

```
k=1.3
rp=6
T1=20+273 "K"
T3=900+273 "K"
Eta_regen=1-(T1/T3)*rp^((k-1)/k)
```

"Some Wrong Solutions with Common Mistakes:"

```
W1_Eta = 1-((T1-273)/(T3-273))*rp^((k-1)/k) "Using C for temperatures instead of K"
W2_Eta = (T1/T3)*rp^((k-1)/k) "Using incorrect relation"
W3_Eta = 1-(T1/T3)*rp^((k1-1)/k1); k1=1.4 "Using wrong k value (the one for air)"
```

9-212 An ideal gas turbine cycle with many stages of compression and expansion and a regenerator of 100 percent effectiveness has an overall pressure ratio of 10. Air enters every stage of compressor at 290 K, and every stage of turbine at 1200 K. The thermal efficiency of this gas-turbine cycle is

- (a) 36% (b) 40% (c) 52% (d) 64% (e) 76%

Answer (e) 76%

Solution Solved by EES Software. Solutions can be verified by copying-and-pasting the following lines on a blank EES screen. (Similar problems and their solutions can be obtained easily by modifying numerical values).

```
k=1.4
rp=10
T1=290 "K"
T3=1200 "K"
Eff=1-T1/T3
```

"Some Wrong Solutions with Common Mistakes:"

```
W1_Eta = 100
W2_Eta = 1-1/rp^((k-1)/k) "Using incorrect relation"
W3_Eta = 1-(T1/T3)*rp^((k-1)/k) "Using wrong relation"
W4_Eta = T1/T3 "Using wrong relation"
```

9-213 Air enters a turbojet engine at 260 m/s at a rate of 30 kg/s, and exits at 800 m/s relative to the aircraft. The thrust developed by the engine is

- (a) 8 kN (b) 16 kN (c) 24 kN (d) 20 kN (e) 32 kN

Answer (b) 16 kN

Solution Solved by EES Software. Solutions can be verified by copying-and-pasting the following lines on a blank EES screen. (Similar problems and their solutions can be obtained easily by modifying numerical values).

```
Vel1=260 "m/s"
Vel2=800 "m/s"
Thrust=m*(Vel2-Vel1)/1000 "kN"
m= 30 "kg/s"
```

"Some Wrong Solutions with Common Mistakes:"

```
W1_thrust = (Vel2-Vel1)/1000 "Disregarding mass flow rate"
W2_thrust = m*Vel2/1000 "Using incorrect relation"
```

9-214 ... 9-220 Design and Essay Problems.

