

SKF solutions for printing,
bindery, finishing, converting
and packaging machinery





The SKF brand now stands for more than ever before, and means more to you as a valued customer.

While SKF maintains its leadership as the hallmark of quality bearings throughout the world, new dimensions in technical advances, product support and services have evolved SKF into a truly solutions-oriented supplier, creating greater value for customers.

These solutions encompass ways to bring greater productivity to customers, not only with breakthrough application-specific products, but also through leading-edge design simulation tools and consultancy services, plant asset efficiency maintenance programmes, and the industry's most advanced supply management techniques.

The SKF brand still stands for the very best in rolling bearings, but it now stands for much more.

SKF – the knowledge engineering company

Contents

3 General introduction

- 3 Every revolution an issue
- 4 Our offers

6 SKF's solutions for printing machinery

- 6 Bearings, units, other products
- 16 Seals
- 19 Mechatronics
- 24 Services
- 28 Lubrication systems
- 32 Designation suffixes

34 Application specific product assortment

- 34 For best performance
- 35 Tables

47 Application examples

52 Printing problems and their solutions

- 52 Register problem
- 52 Stripes and ghosting problems

54 SKF – the knowledge engineering company

General introduction



- streamline the design cycle and speed time-to-market
- improve the manufacturing and assembly process.

In the printing, finishing and converting industries, make-ready can be time consuming and expensive. The cost of a non-productive machine, wasted paper and labour can add up quickly when the rolls and blankets in each tower have to be cleaned and adjusted for register and ink balance. These costs are particularly important to your customers for short runs, where make-ready costs can represent a significant percentage of the total printing cost.

To reduce the time it takes for a make-ready, SKF has a number of innovative solutions. These solutions can not only impact the make-ready costs but can also reduce maintenance costs and associated downtime costs.

Every revolution an issue

Today, the value of a printing press and other finishing and converting equipment is often measured by price per job. Which is why in the highly competitive printing, finishing and converting industries, your customers need innovative, efficient and reliable machines. At SKF we are continually improving our products and developing new solutions so that you can better meet the needs of your customers for cost-effectiveness and reliability and most importantly, quality.

Your benefits

As every design engineer knows, all the components in a complex mechanical device like a printing press, bookbinding and print finishing or converting machine are interrelated. Loads and stresses placed on a housing, frame, shaft or other mechanism have an impact on the performance of the bearings, seals, and lubricants, and vice versa. So it makes sense to look at the design from a systems point of view, factoring in how components interact with each other over a wide range of operating conditions. The challenge is finding a design partner with expertise in not just one,

but all the areas critical to machine performance and service life.

Whether your application is rotary, linear, or a combination of the two, SKF can help.

With competency in bearings, seals, lubrication systems, linear motion, sensors and condition monitoring, SKF can provide a total systems approach to optimize your offset, flexo or gravure press. In addition, many of the solutions we provide are applicable to folders, cutters, stitchers, gathering machines, embossing machines or complete automatic bookbinding lines, conveyor systems, mail-room equipment, machines for converting carton, corrugated board and flexible materials. As your partner in the design of printing, bindery and converting equipment, SKF can help you

- make designs more compact
- enable equipment to operate faster and smoother
- improve product reliability and decrease warranty claims
- reduce energy consumption and lubricant use
- reduce, simplify or eliminate maintenance
- minimize environmental impact



Striving for high quality

The ability to maintain consistent, high print quality is a constant end user requirement. High-precision, accuracy, as well as a high degree of stiffness of the bearing solutions found on a press are key to maintaining that level of quality. The ability to accurately register the printing cylinders or provide an even distribution of ink and water in the inking and dampening system are also key factors in maintaining the quality of the final print job.

For many years SKF has been a partner to the printing industry. By combining application knowledge with engineering and manufacturing expertise, SKF can provide you with a wide range of solutions and services to help you meet your customers' expectations.

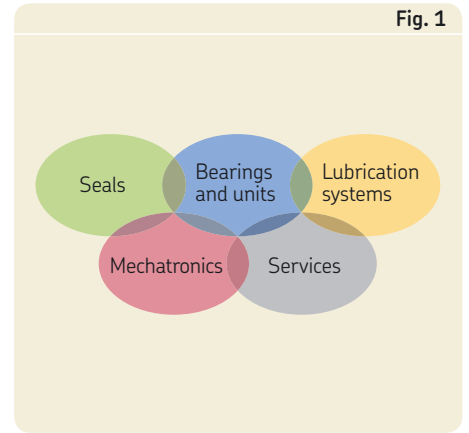


Unexpected breakdowns are expensive

To maximize profitability, the presses must be kept rolling at maximum speed with a minimum amount of maintenance and downtime. Which is why presses equipped with reliable solutions from SKF pay off. To improve reliability even further, monitoring the condition of critical components can help to identify potential problems before they become catastrophic failures. With a wide range of condition monitoring solutions from SKF, your customers can avoid costly, unexpected downtime.

Ambition to optimize

Improving productivity is one of the daily pressures for OEMs and end users alike. As a result, there is an ever increasing trend to identify solutions that will not only reduce components and simplify installation but can also increase machine speeds while maintaining print quality. To meet those goals, SKF has a wide range of bearings, seals, actuators, lubrication systems, condition monitoring solutions and engineering services at your disposal.



Our offers

Design services

To select the most appropriate bearing solution for your printing press or other equipment, SKF engineers have a number of tools at their disposal. These tools range from the simple life calculation tools found in the SKF Interactive Engineering Catalogue, to proprietary SKF software that simulates actual operating conditions.

Solution products

SKF offers a wide variety of high quality solution products for the printing, bindery and converting industry. These products, which include bearings and bearing units, seals, lubricants and lubrication systems, mechatronics and linear motion devices, speciality products and services (→ fig. 1) are available locally and globally so that you and your customers can minimize maintenance and downtime.

Lubricant selection and lubrication delivery systems

To maximize bearing service life, using the appropriate lubricant can be just as important as the lubrication delivery system in your press and ancillary equipment – which is why SKF engineers regularly partner with engineers from Vogel, a world leader in lubricant delivery systems, and a member of the SKF Group. With their combined knowledge, these engineers can work with you to improve reliability, decrease the need for maintenance and ultimately decrease downtime.



Printing cylinders

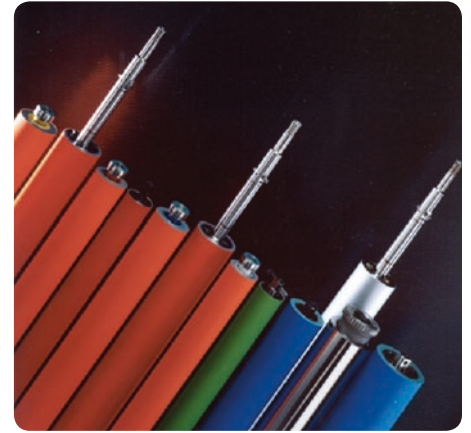
In order to obtain high quality results, printing cylinders must operate precisely, with optimized clearance or preload settings. Even the slightest inaccuracy can affect print quality.

To maintain the highest levels of quality, SKF recommends using any of the following solution products designed specifically for printing cylinders:

- Printing cylinder bearing units (→ **page 12**).
- Printing cylinder systems (→ **page 12**).
- High-precision spherical roller bearings (→ **page 12**).
- High-precision tapered roller bearings (→ **page 13**).
- High-precision cylindrical roller bearings (→ **page 10**).

Bearings should be selected carefully, considering all prevailing application conditions – regardless of whether it concerns web or sheet fed offset machines, flexographic or gravure presses.







Bearings are only one important component of a printing cylinder. The ability to adjust the cylinder for proper registration (sidelay, circumferential and cocking) is equally important. To do this, engineers from Scandrive, a member of the SKF Group, can work with you to find a compact integrated actuation unit (→ **page 20**) that meets the needs of your application.



Inking and dampening systems

In addition to the wide variety of standard bearing solutions, SKF also offers unique solutions developed specifically for the inking and dampening systems in printing presses. Unique solutions include products like SKF cylindrical roller bearings with an extended inner ring (→ **page 9**) and oscillating bearing units (→ **page 10**). These “plug and play” units combine SKF’s extensive knowledge in bearings, seals, lubrication and actuation.

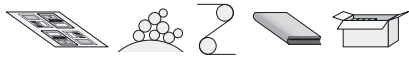
*The table shows a summary of SKF’s offer portfolio for your applications
The figures in the table correspond to the pages where related information can be found*

Page references						
Application/Technology platform						
Applications	Technology platforms					
	Bearings	Seals	Mechatronics	Services	Lubrication	
–						
 Pre-press	page 6	pages 16–18	page 22	page 27	page 28	
 Printing cylinders	pages 7–14	pages 16–18	pages 19–20, 22	pages 25–27	pages 28–31	
 Inking and dampening system	pages 6, 9–11, 14	pages 16–18	pages 19–23	pages 26–27	pages 28–31	
 Web guiding rollers	pages 6, 11, 14–15	pages 16–17	page 22	page 27	page 28	
 Bookbinding and print finishing	pages 6–9, 11–15	pages 16–18	page 22	pages 26–27	pages 28–31	
 Paper converting and packaging	pages 6–9, 11–15	pages 16–18	page 22	pages 26–27	pages 28–31	

SKF solutions for printing machinery

Bearings, units, other products

Deep groove ball bearings



Single row deep groove ball bearings can accommodate relatively heavy radial loads and light to moderate axial loads simultaneously, from either direction, even at high speeds.

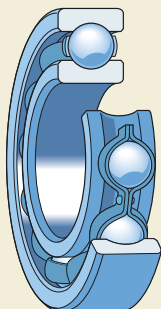
The basic design is open (unsealed) (→ **fig. 1**). However single row deep groove ball bearings are also available with shields (suffix Z), low-friction seals (suffix RSL or RZ) or contact seals (suffix RSH or RS1) (→ **fig. 2**) on one or both sides.

Deep groove ball bearings are used in virtually every application. Applications include inking, dampening and web guiding rollers (→ **fig. 14 on page 51**) in printing presses and in bookbinding, print finishing, converting and packaging machinery.

For additional information, see the SKF General Catalogue or the SKF Interactive Engineering Catalogue.

Deep groove ball bearing – open design

Fig. 1



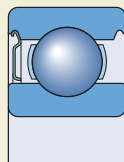
SKF Explorer deep groove ball bearings

SKF Explorer deep groove ball bearings are characterized by their long service life. This has been made possible by improvements to the internal geometry, materials, cage design and ball quality. The result is a bearing that runs cooler, smoother and longer.

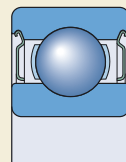
For additional information, see the SKF General Catalogue or the SKF Interactive Engineering Catalogue.

Deep groove ball bearings with shields and seals

Fig. 2

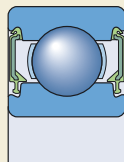


Z

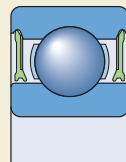


2Z

Bearing with one or two shields

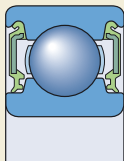


2RSL

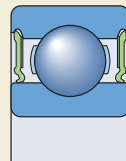


2RZ

Bearing with one or two low-friction seals



2RSH



2RS1

Bearing with one or two contact seals

Self-aligning ball bearings



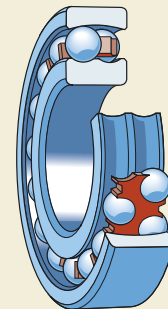
Self-aligning ball bearings have two rows of balls with a common sphered raceway in the outer ring. This enables the bearing to accommodate misalignment of the shaft relative to the housing. Standard SKF self-aligning ball bearings are of open design (→ **fig. 3**) with either a cylindrical or tapered bore (taper 1:12). They are also available with seals (→ **fig. 4**).

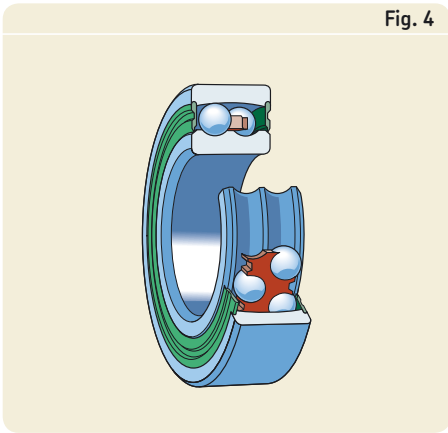
Self-aligning ball bearings are typically used when the length of the roller makes it susceptible to shaft deflections. Applications include inking and dampening rollers, and web guiding rollers (→ **fig. 15 on page 51**) as well as print finishing and converting equipment.

For additional information, see the SKF General Catalogue or the SKF Interactive Engineering Catalogue.

Self-aligning ball bearing

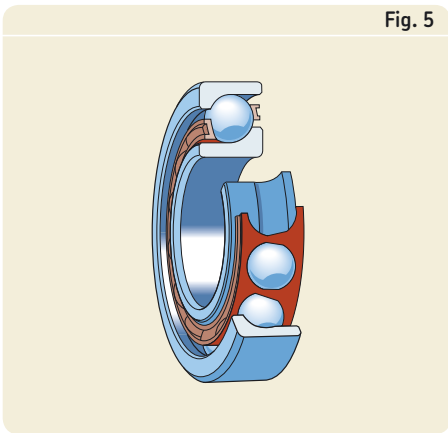
Fig. 3





Sealed self-aligning ball bearing

Single row angular contact ball bearing



Angular contact ball bearings

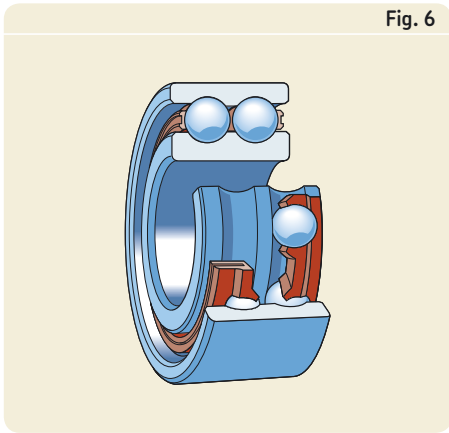


SKF angular contact ball bearings are produced in a wide variety of designs and sizes and are used extensively in printing presses, finishing and converting machines.

Angular contact ball bearings have raceways in the inner ring and outer ring that are displaced relative to each other in the direction of the bearing axis. This means that they are designed to accommodate combined loads, i.e. simultaneously acting radial and axial loads.

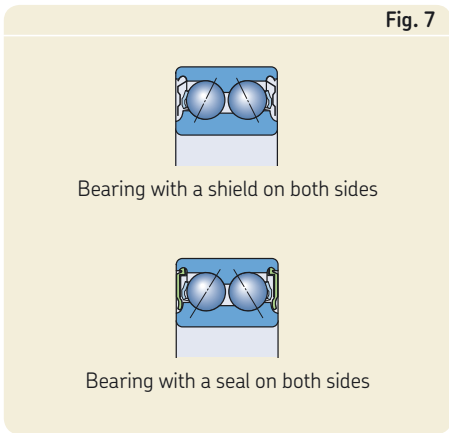
The most commonly used angular contact ball bearings include

- single row angular contact ball bearings (→ fig. 5)
- double row angular contact ball bearings (→ fig. 6)
- four-point contact ball bearings (→ fig. 8).



Double row angular contact ball bearing

Sealed double row angular contact ball bearings



For additional information, see the SKF General Catalogue or the SKF Interactive Engineering Catalogue.

Single row angular contact ball bearings

A single row angular contact ball bearing can accommodate axial load in one direction only (→ fig. 5). The bearing is normally adjusted against a second bearing.

The axial load carrying capacity of angular contact ball bearings increases with increased contact angle. This is particularly important in a variety of applications where the 40° contact angle of an SKF single row angular contact ball bearing can provide long service life.

Universal matching

At SKF, universally matchable single row angular contact ball bearings are standard. These bearings, which have the proper clearance or preload built right in, can simplify installation and dramatically increase the service life of the machine while decreasing maintenance costs. The available clearance and preload classes cover almost all possible application requirements.

Universally matchable single row angular contact ball bearings are commonly used for the axial support of printing cylinders together with printing cylinder bearing units or systems (PCU, PCS) (→ fig. 2 on page 47 and fig. 3 on page 48) for supporting radial loads. When using universally matched single row angular contact ball bearings in printing cylinder applications, SKF recommends a light preload designation suffix GA.

Double row angular contact ball bearings

Double row angular contact ball bearings (→ fig. 6) have a 30° angle and can accommodate relatively heavy combined loads (radial loads as well as axial loads acting in both directions). These bearings are available in an open design or with seals or shields (→ fig. 7).

Double row angular contact ball bearings are commonly used as the locating bearing in printing cylinders and gear transmissions and in other applications, where the load carrying capacity of a deep groove ball bearing is not adequate.

SKF Explorer angular contact ball bearings

SKF Explorer single row angular contact ball bearings are manufactured from high quality, ultra clean steel. Their sophisticated design and world-class manufacturing processes result in a higher degree of running accuracy. Other improvements, which include a unique heat treatment, higher ball quality and re-designed cages, have reduced the frictional moment so that less heat is generated by the bearing. Additional benefits include reduced noise and vibration levels and a substantial increase in bearing service life to provide significant total cost advantages.

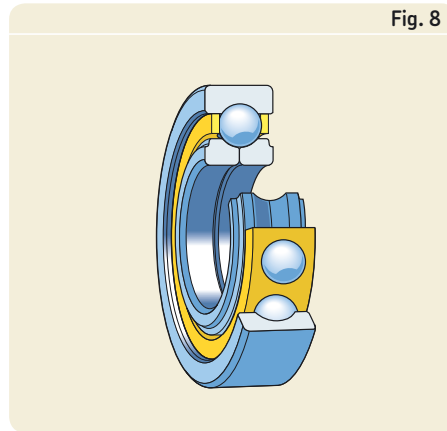
Four-point contact ball bearings

Four-point contact ball bearings are single row angular contact ball bearings with raceways that are designed to support axial loads in both directions. (→ **fig. 8**). They are typically used when axial space is limited or when there is a need to develop a more compact solution. These bearings are usually used in the locating position, with a cylindrical roller bearing in the non-locating position. Four-point contact ball bearings are often used in the drive arrangement of web and sheet fed presses.

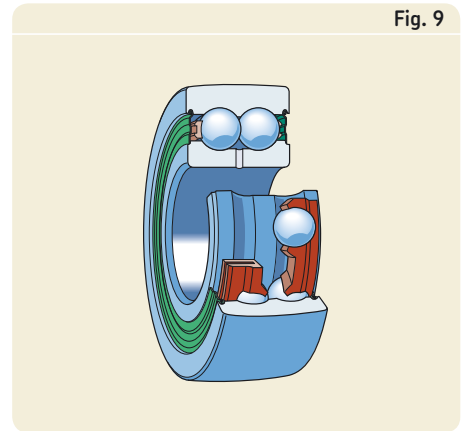
SKF Explorer four-point contact ball bearings

SKF Explorer four-point contact ball bearings are characterized by their unique internal design. When combined with improvements in the quality of the bearing steel and SKF manufacturing processes, these bearings run quieter and cooler, with lower vibration levels. The result: significantly longer bearing service life.

For additional information, see the SKF General Catalogue or the SKF Interactive Engineering Catalogue.



Four-point contact ball bearing



Double row cam roller

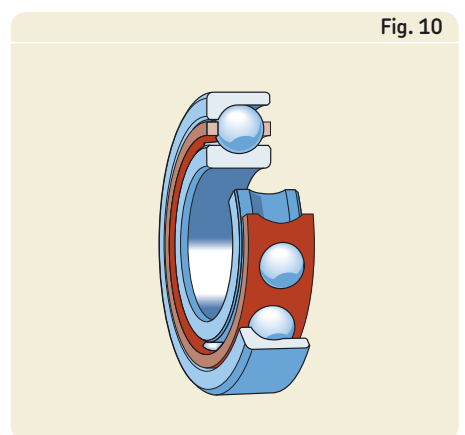
Double row cam rollers

SKF double row cam rollers, (→ **fig. 9**) developed from double row angular contact ball bearings, have a 25° contact angle. These sealed and pre-greased ready-to-mount units are widely used in finishing machines like folders, cutters, gathering machines and bindery lines.

For additional information, see the SKF General Catalogue or the SKF Interactive Engineering Catalogue.

High-precision angular contact ball bearings

SKF high-precision angular contact ball bearings (→ **fig. 10**) are produced in three different dimension series – 719, 70 and 72 – and are available with contact angles of 15° (suffix CD or CE), 18° (suffix FB) and 25° (suffix ACD, ACE). Bearings for universal matching are identified by the designation suffix G, followed by A, B, or C for the preload class (e.g. 71910ACDGA/P4A). Sets of two bearings with matched bore and outside diameter are also available. Depending on the preload class, these carry the designation suffix DGA, DGB, or DGC (e.g. 7006 CD/P4ADGB). Also, matched sets of two or more bearings can be supplied.



High-precision angular contact ball bearing

High-precision angular contact ball bearings are produced as standard to P4A tolerance class specifications and are used for precision applications like the printing and transfer cylinders in sheet fed presses.

For unique applications, an even more accurate high-precision class (PA9A) is available.

For additional information, see the SKF High-precision bearings catalogue or the SKF Interactive Engineering Catalogue.

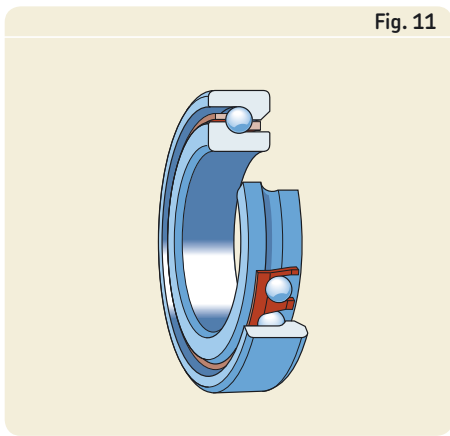


Fig. 11

Angular contact thrust ball bearing

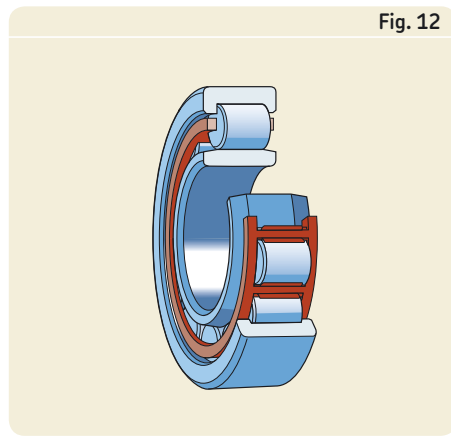


Fig. 12

Cylindrical roller bearing

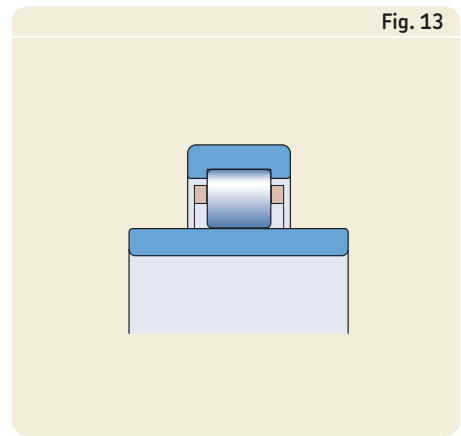


Fig. 13

Cylindrical roller bearing with an extended inner ring

Angular contact thrust ball bearings

Whenever an application calls for a high degree of stiffness, high axial load carrying capacity and a high degree of running accuracy, angular contact thrust ball bearings can be an excellent choice (→ fig. 11). These non-separable bearings, which incorporate a large number of balls, have a high degree of osculation, and a 60° contact angle.

Also known as ball screw support bearings, angular contact thrust ball bearings are typically found on the printing cylinders of flexographic presses.

SKF angular contact thrust ball bearings are available in the BSA and BSD series. On request they can be supplied as single, universally matchable bearings, designation suffix G, followed by an A or B to indicate preload. GA represents light preload while GB represents heavy preload (e.g. BSD 3572 CGB). Also matched sets of two or more bearings with matched bore and outside diameter can be supplied. These matched sets are available in preload class A or B as well (e.g. BSD 45100 C/DFA – stands for two single bearings matched in a face-to-face arrangement with light preload).

Cylindrical roller bearings



Single row cylindrical roller bearings are produced to various designs. For applications where there are heavy, purely radial loads, NU (→ fig. 12) or N design cylindrical roller bearings can be used. If in addition to radial loads, the bearings are subjected to light axial loads acting in one or both directions, NJ or NUP design bearings can be used. The NJ and NUP designs are typically used in the gearing and power transmission systems used on printing presses. In applications where there are very heavy radial loads either NCF type single row or NNF type double row full complement cylindrical roller bearings can be used.

For additional information, see the SKF General Catalogue or the SKF Interactive Engineering Catalogue.

SKF Explorer cylindrical roller bearings

SKF Explorer cylindrical roller bearings are setting a new standard with respect to performance and endurance. Intensive development and testing has resulted in a number of improvements. SKF Explorer cylindrical roller

bearings can last up to three times longer than conventional cylindrical roller bearings.

Power-up, size down, or simply increase maintenance intervals and service life. The choice is yours.

Cylindrical roller bearings for oscillating rollers

SKF has developed a cylindrical roller bearing (→ fig. 13) that was designed specifically for inking and dampening rollers (→ fig. 10 on page 50). These well proven bearings have an extended inner ring to accommodate axial oscillating movements while the bearing is rotating. These bearings are fitted with a cage of glass fibre reinforced polyamide 6.6 and are usually grease lubricated, however, they can be integrated into a central oil recirculation lubrication system.

For additional information, contact the SKF application engineering service.

High-precision cylindrical roller bearings

For very precise applications high-precision double row cylindrical roller bearings in the NNU 49 series (→ **fig. 14**) and NN 30 series (→ **fig. 15**) are typically used. The rollers of a NNU type bearing are guided between the flanges of the outer ring while the rollers of a NN type bearing are guided between the flanges of the inner ring.

Bearings in the NN and NNU series meet Special Precision (SP) tolerances and are available with either a cylindrical or tapered bore (taper 1:12). They are supplied with a C1 radial clearance as standard. They are fitted with either brass or polyamide 6,6 cages, depending on bearing size.

High-precision cylindrical roller bearings are well suited to support any type of printing cylinder. NNU 49 design bearings are often used in the transfer and impression cylinders of sheet fed presses (→ **fig. 8** on **page 49**). NN 30 design bearings form the basis of the SKF printing cylinder bearing unit (PCU) (→ **page 12**) used in the plate and blanket cylinders of web and sheet fed offset presses.

For additional information, see the SKF High-precision bearings catalogue or the SKF Interactive Engineering Catalogue.

Oscillating bearing unit (OBU)

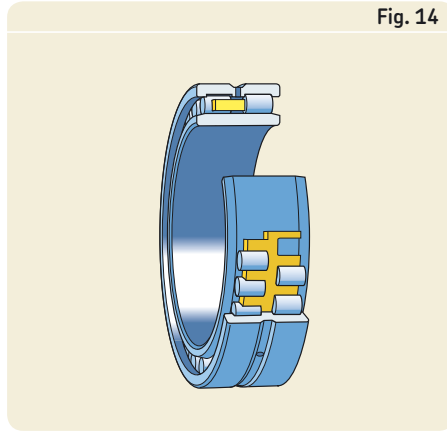


Cylindrical roller bearings with an extended inner ring were such a success with OEMs that SKF took the concept one step further and developed the oscillating bearing unit for inking and dampening rollers (→ **fig. 11** on **page 50**). Based on the cylindrical roller bearing for oscillating rollers, these easy-to-install bearing units, include a housing, bearing, seals and lubricant and can be delivered with (→ **fig. 16**) or without a shaft (→ **fig. 17**). These units are designed and manufactured to meet the needs of specific customer applications.

Benefits of an SKF oscillating bearing unit include

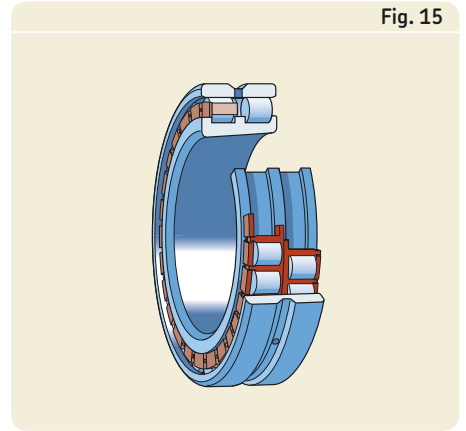
- simplified installation
- reduced need for maintenance
- improved total machine economy.

Fig. 14



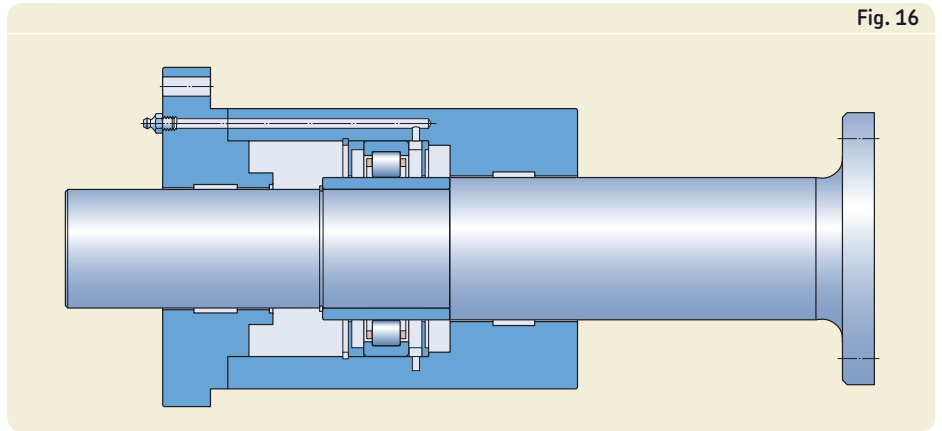
High-precision double row cylindrical roller bearing in the NNU 49 series

Fig. 15



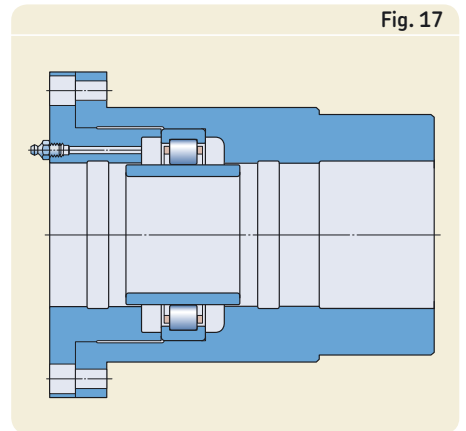
High-precision double row cylindrical roller bearing in the NN 30 series, with a tapered bore

Fig. 16



The pre-lubricated and ready to install SKF OBU unit consists of a bearing, housing, seals and shaft

Fig. 17



The pre-lubricated and ready to install SKF OBU unit consists of a bearing, housing and seals, without a shaft

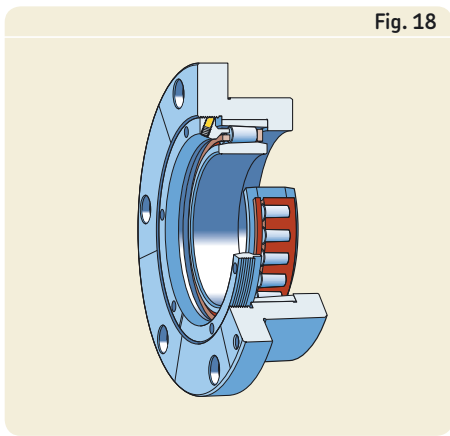


Fig. 18

SKF PANLOC

Drawn cup needle roller bearing

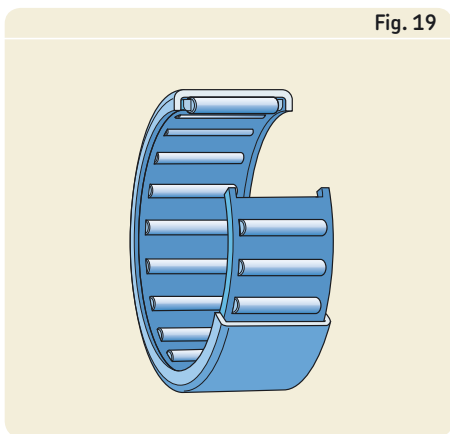


Fig. 19

SKF PANLOC



In response to the printing industry's needs for higher process reliability and productivity without compromising quality, SKF has developed a non-locating bearing unit called SKF PANLOC (→ fig. 18). PANLOC stands for pre-adjustable non-locating bearing unit.

PANLOC is an easy to mount bearing unit that can be used on the plate, blanket, impression or transfer cylinders of offset presses (→ fig. 9 on page 50). The bearing unit enables the operator to adjust clearance or preload precisely via markings on the bearing outer ring and nut. As is the case with most cylindrical roller bearings, thermal expansion of the shaft can be accommodated within the bearing, without generating internal axial forces.

These bearing units make it possible to design bearing arrangements in which system

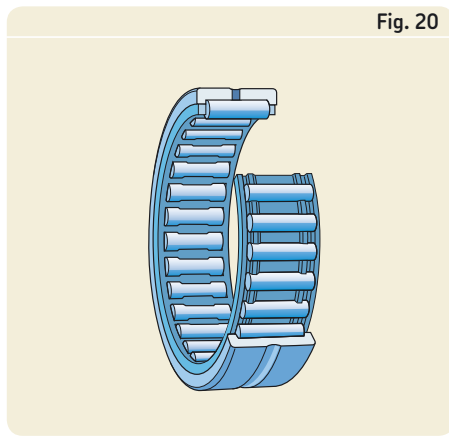


Fig. 20

Needle roller bearing without an inner ring

Needle roller bearing with an inner ring

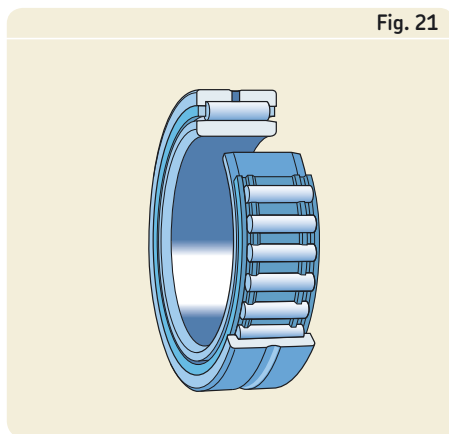
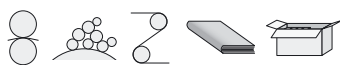


Fig. 21

life, a high degree of stiffness and heat build-up are optimally attuned to each other.

An excellent example is the use of an SKF PANLOC in the plate cylinder of a sheet fed offset press. The bearing unit enables easy and quick installation and adjustment of either clearance or preload.

Needle roller bearings



Needle roller bearings incorporate cylindrical rollers, which are relatively long but small in diameter. In spite of their low cross section, these bearings have a high load carrying capacity, making them suitable for bearing arrangements where radial space is limited.

Commonly used types are

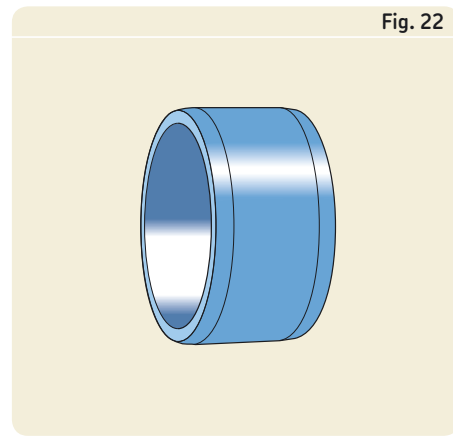


Fig. 22

Inner ring

- drawn cup needle roller bearings (→ fig. 19)
- needle roller bearings without an inner ring (→ fig. 20)
- needle roller bearings with an inner ring (→ fig. 21).

For applications where an adequate seal is not available or cannot be provided for space reasons, sealed needle roller bearings can be supplied. Standard needle roller bearings, which at one time were used extensively on printing cylinders, are being replaced with high-precision spherical roller bearings (→ page 12) or printing cylinder bearing units (PCU) (→ fig. 23 on page 12) that incorporate both cylindrical and needle rollers into a single unit. Needle roller bearings are, however, widely used in the less critical positions of finishing machines.

For additional information, see the SKF Needle roller bearings catalogue or the SKF Interactive Engineering Catalogue.

Inner rings

SKF supplies loose inner rings (→ fig. 22) for needle roller and cylindrical roller bearings for applications where the shaft cannot be hardened and ground. Inner ring widths can be standard or extended. An extended inner ring enables larger axial displacements of the shaft relative to the housing and also provides an excellent surface for contact seals.

Printing cylinder bearing units (PCU)



SKF printing cylinder bearing units (PCU) (→ **fig. 23**) combine the separate components of a traditional bearing arrangement into a compact self-contained unit. Several designs are available in a range of sizes tailored to meet the needs of the press.

Printing cylinder bearing units are based on the high-precision cylindrical roller bearings in the NN 30 series. These multi-row (2, 3 or 4) cylindrical roller bearings can contain one or two eccentric intermediate rings, each supported by a double row needle roller and cage assembly. The needle roller and cage assemblies provide smooth adjustment of the eccentric rings while the press is in operation, for functions like print on/off, cocking and adjustment of paper thickness.

Printing cylinder bearing units can also be used in other applications where eccentricity is needed.

For additional information, visit www.skf.com under Industries/Printing machines.

Printing cylinder systems (PCS)

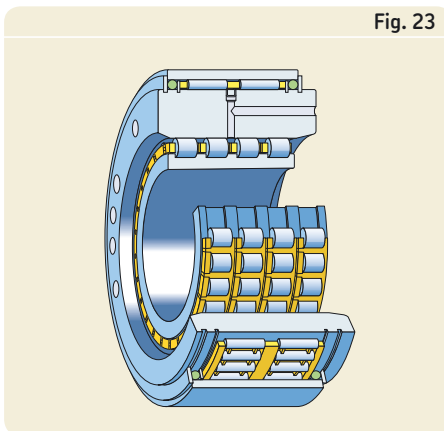


To build on the success of the printing cylinder unit, SKF developed the printing cylinder system (→ **fig. 24**). This system incorporates bearings, grease and seals into a compact ready-to-install envelope.

Benefits of printing cylinder systems:

- Simple to mount.
- Eliminates or reduces the need for maintenance.
- Engineered to meet the needs of a specific press design.

Fig. 23



Printing cylinder bearing unit (PCU)

Simplify the mounting process

Mounting an SKF printing cylinder system into the side frame of a press has never been easier. The process is simplified by a ring with a tapered bore that fits over the tapered outside diameter of the bearing outer ring. When the two are displaced in opposite directions, the clearance between the ring and the bore of the side frame decreases and results in a tight fit with a high degree of stiffness.

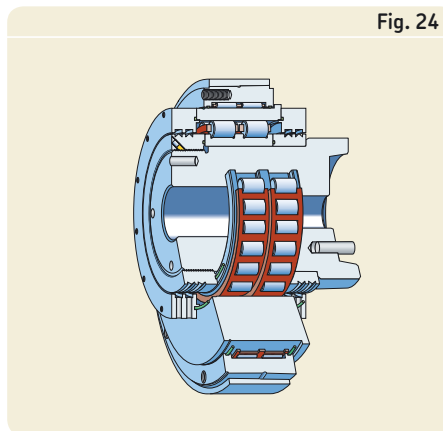
It is no longer necessary to match the outer ring of the bearing with the side frame bore diameter, which simplifies the inventory and installation processes.

By incorporating the printing cylinder journal into the bearing system installation is faster and easier.

Virtually eliminate or reduce the need for maintenance

Printing cylinder systems can be delivered sealed, and pre-lubricated with the appropriate type and amount of grease. These systems, have been shown to substantially extend relubrication intervals thereby reducing maintenance and downtime costs.

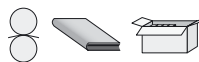
Fig. 24



Printing cylinder system (PCS) shown with

- Part of the printing cylinder incorporated in the bearing system
- Sealed and grease lubricated bearing unit
- A ring with a tapered bore to facilitate installation

Spherical roller bearings



Spherical roller bearings are self-aligning double row roller bearings (→ **fig. 25**) that are insensitive to misalignment of the shaft relative to the housing. They can also accommodate shaft deflections without any adverse affect on bearing performance.

In addition to heavy radial loads, spherical roller bearings can accommodate axial loads acting in both directions. Spherical roller bearings with Normal tolerances are used in the power transmission of printing presses or to support long rollers that are subjected to deflections. SKF supplies high-precision spherical roller bearings for the printing cylinder in web offset presses. (→ **fig. 5** on **page 49**). These bearings are identified by the designation suffixes VA751, VA759, VAB or VAE.

For additional information, see the SKF General Catalogue or the SKF Interactive Engineering Catalogue.

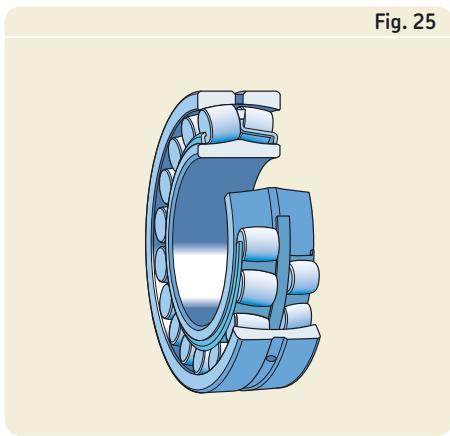


Fig. 25

Spherical roller bearing

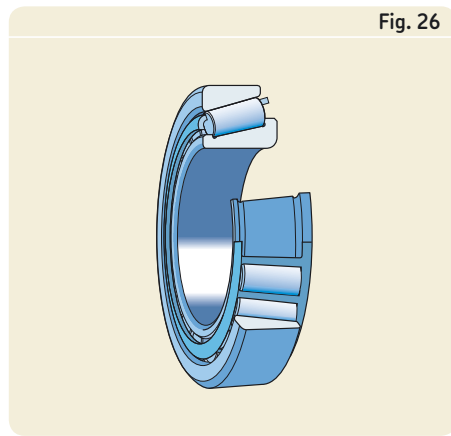


Fig. 26

Tapered roller bearing

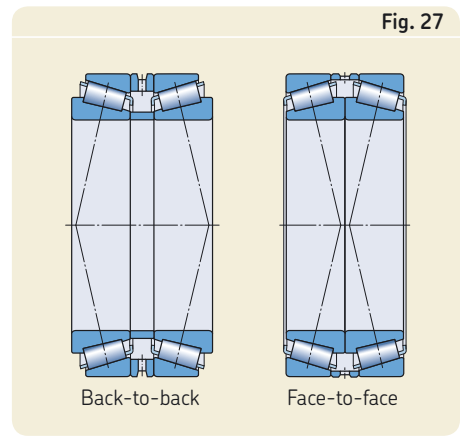


Fig. 27

Paired sets of tapered roller bearings

SKF Explorer spherical roller bearings

SKF Explorer spherical roller bearings represent a quantum leap in bearings performance and are the state-of-the art in spherical roller bearing technology. Their performance is so consistent and outstanding that they have been certified by Germanischer Lloyd and Det Norske Veritas.

The bearings can last up to three times longer than previous designs. In addition, the very tight dimensional tolerances achieved with the upgraded manufacturing process has improved the running accuracy to P5 tolerance, an extraordinary achievement for standard bearings.

All in all, the longer service life and improved precision of SKF Explorer spherical roller bearings provide new opportunities to size-down an application. Sizing down not only provides reduced noise and vibration levels, but also builds additional value into your application by increasing speed, improving service intervals, reducing heat and power consumption and controlling maintenance costs.

Tapered roller bearings



Single row tapered roller bearings are designed to accommodate combined heavy radial and axial loads (→ fig. 26). Two bearings on the shaft are adjusted against each other to obtain clearance or preload, depending on the requirements of the application.

For bearing arrangements where the shaft has to be axially located in both directions with a given preload or clearance, SKF can supply matched bearing sets arranged back-to-back (suffix DB) or face-to-face (suffix DF) (→ fig. 27). SKF TQ-Line tapered roller bearings and SKF CL7C specification tapered roller bearings are widely used on the printing cylinders of web presses. Both meet P5 running accuracy requirements. The bearing you choose depends on the requirements of the application relative to preload, stiffness and operating temperature.

For additional information, see the SKF General Catalogue or the SKF Interactive Engineering Catalogue.

SKF offers a special tailored range of high-precision tapered roller bearings for the printing and transfer cylinders of sheet fed presses (→ fig. 28) (→ fig. 4 on page 48). These special bearings are based on the double row tapered roller bearing with the roller rows arranged back-to-back. These bearings, which are mounted with a preload, meet P4 running accuracy tolerances.

For additional information contact the SKF application engineering service.

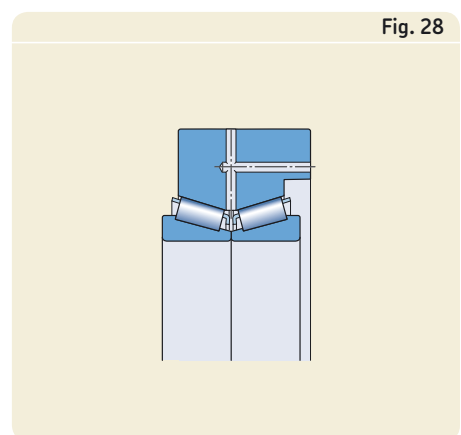


Fig. 28

Special tapered roller bearing

SKF Explorer tapered roller bearings

SKF Explorer tapered roller bearings represent a completely new performance class with significantly improved performance parameters. Technologically they offer clear advantages over the TQ-Line bearings. Their significantly longer service life has been verified in various inhouse and independent tests. The quality of the inner and outer ring raceway surfaces as well as of the rollers has been further optimized, as have been the contact profiles.

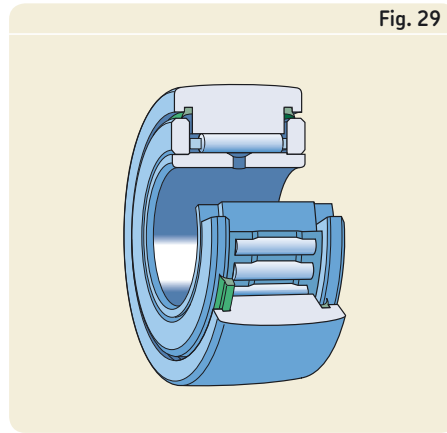
This results in higher load carrying capacity and reference speeds, much longer service life, better performance under poor lubrication conditions, lower operating temperatures, lower vibration levels – in other words, a plus in economic efficiency.

Track runner bearings

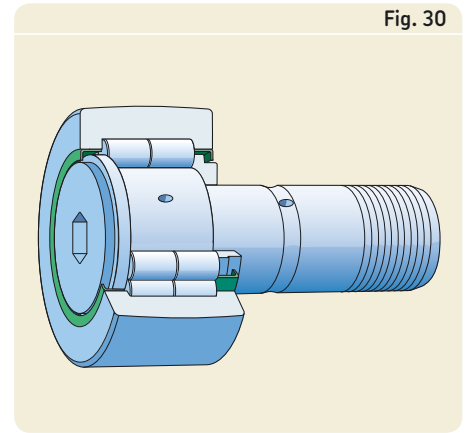


Support rollers (→ **fig. 29**) and cam followers (→ **fig. 30**), have a particularly thick-walled outer ring to accommodate heavy loads and shock loads. These bearings can be used in all types of printing presses and paper handling systems. They are also widely used in folders, die-cutters, gathering machines, book bindery lines and other applications.

For additional information see the SKF Needle roller bearings catalogue or the SKF Interactive Engineering Catalogue.

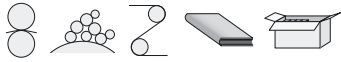


Support roller



Cam follower

Y-bearings & units

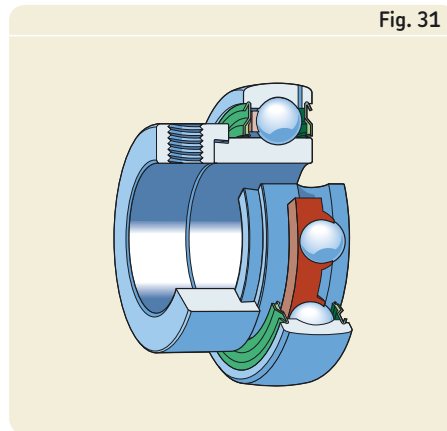


SKF Y-bearings, which are usually referred to as insert bearings, are basically sealed deep groove ball bearings in the 62 and 63 series with a convex sphered outer surface. These bearings are manufactured in a number of different series and sizes and are available with either a standard inner ring or an inner ring that is extended on one or both sides. The various bearing series differ in the way the bearing is located onto the shaft (→ **fig. 31**).

Y-bearings mounted in standard Y-bearing housings form Y-bearing units, which are available in many different types and sizes (→ **fig. 32**). Y-bearing units can accommodate moderate initial misalignment but normally do not permit axial displacement. Because of their simplicity, versatility and cost-effectiveness, economical bearing arrangements can be made using these units.

SKF Y-bearings and Y-bearing units are very often used for different kinds of rollers for web guiding, in bookbinding and print finishing lines and packaging machines.

For additional information see the SKF Y-bearings and Y-bearing units catalogue or the SKF Interactive Engineering Catalogue.



Y-bearing with an eccentric locking collar



Y-bearing plummer block unit



Fig. 33

Plain bearings

Plain bearings



In addition to ball and roller bearings SKF also produces a comprehensive assortment of spherical plain bearings, rod ends and dry sliding bushings, washers and strips in various designs and with various combinations of sliding contact surfaces (→ **fig. 33**). Each design and combination has characteristic properties that make it particularly suitable for certain applications.

These products are mainly used in paper converting and packaging machines and in print finishing and bookbinding equipment. To select a certain bearing type and to establish the requisite bearing size, the main factors to consider are the loads, the load carrying capacity of the bearing and the expected service life.

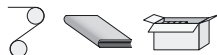
For additional information see the SKF Plain bearings catalogue or the SKF Interactive Engineering Catalogue.



Fig. 34

SKF ConCentra locking bushing

SKF ConCentra



SKF has developed a locking technology called SKF ConCentra that can be used in rolling bearing units and for other components to be mounted on a shaft. It is used in different applications like transmissions, to precisely lock gearwheels. ConCentra is also used on guiding rollers and in print finishing and converting equipment (→ **fig. 1** on **page 47**).

The ConCentra stepped sleeve, a masterpiece of locking technology, combines simplicity with reliability. The locking concept is based on two mating surfaces with precision-engineered inclined serrations on their contact surfaces. These mating surfaces respond to axial displacement by expanding and contracting evenly around the entire circumference of the shaft. The stepped sleeve is equipped with a mounting and a pressure ring. By tightening the grub (set) screws in the mounting ring, using the hexagonal key (allen

wrench) supplied with each unit, the pressure ring forces the inner ring up the inclined planes of the stepped sleeve to provide a true concentric tight fit on the shaft.

In addition to the SKF ConCentra locking bushing (→ **fig. 34**) ConCentra locking technology is also available in SKF's wide assortment of spherical roller and ball bearing units. These ready-to-install bearing units, which include a housing, a sealed bearing and the SKF ConCentra stepped sleeve, are pre-assembled and greased at the factory. With pre-assembled and sealed bearing units, there is a reduced risk of contaminants entering into the bearing cavity. The environment also benefits, as the bearing is filled with the appropriate amount of lubricant at the factory. For many applications, these bearing units can be regarded as being lubricated for life.

Installation is also simplified, as there is no need for keyways or other locking devices. And unlike other types of bearing units, the chance that a locking screw scores or damages the shaft is eliminated. When the unit is installed with the supplied hexagonal (allen) wrench, which has a built-in torque indicator, the true concentric hold of the ConCentra unit keeps the unit secured to the shaft.

For additional information about SKF ConCentra see the SKF Interactive Engineering Catalogue.

Seals

Bearing arrangements do not consist only of bearings, but also include associated components, like a shaft, housings and seals. The performance of the seal is critical to bearing service life, as contaminants that enter into the bearing can quickly cause premature bearing failure.

For this reason, SKF offers seals in a variety of designs and executions from a huge standard assortment. Drawing on their extensive knowledge of bearings, seals, lubricants and lubrication delivery systems, SKF engineering support can work with you to find the most suitable sealing solution for your application. In addition to the main task of a seal to retain lubricant and exclude contaminants, other key issues to be considered in printing applications include operating temperatures, friction and wear as well as resistance to solvents and washing fluids.

Excluding integral bearing seals, (bearing seals are covered in the chapter “Bearings, units, other products”) the types of seals used in printing presses and print finishing machines include the following

- radial shaft seals (includes ICOS)
- axial shaft seals (V-rings)
- labyrinth seals
- O-rings
- wear sleeves as a special accessory.



Radial shaft seals

Radial shaft seals

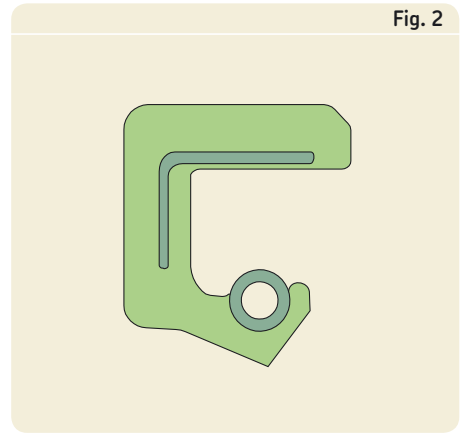


Radial shaft seals, (→ **fig. 1**) which are used between rotating and non-rotating machine components, are available in a variety of types and styles (→ **figs. 2 and 3**) with different lip materials.

The SKF waveseal touches the shaft in a wide sine wave pattern. Due to this unique design, contact pressure and grooving are minimized. Friction and heat generation are also minimal. Lubricant is pumped back to the bearing while dirt is pushed away from the lip/shaft interface.

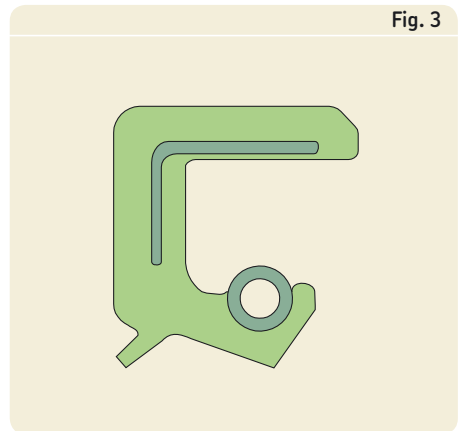
Waveseal features

- Bi-rotational, hydrodynamic radial lip design
- Smooth moulded lip
- Provides exceptional sealing performance with less pressure and a wider contact pattern than required by conventional trimmed lip seals (including other hydrodynamic types)
- Generates hydrodynamic action that provides better lip lubrication and greatly reduces shaft wear
- Pumps lubricant in, while sealing contaminants out
- Boretite coating on the seal outside diameter



Radial shaft seal – single lip design

Radial shaft seal single lip design with an auxiliary lip



Benefits of the SKF waveseal

- Generates less heat
- Creates less drag
- Reduces shaft wear
- Extends seal service life
- Low ingress of contaminants
- Maintains fresh oil film
- Boretite fills small bore imperfections; resists heat and chemicals

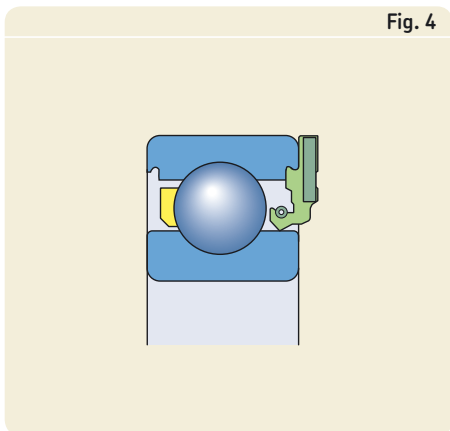


Fig. 4

ICOS

ICOS sealed bearing units



Fig. 5

ICOS sealed bearing units



ICOS, a unique bearing and seal unit developed by SKF (→ figs. 4 and 5), is typically used in applications where sealing requirements exceed the capabilities of standard sealed bearings. An ICOS unit consists of a deep groove ball bearing in the 62 series and an integral SKF radial shaft seal. These units need less axial space than a standard bearing used in conjunction with an external seal. ICOS units also simplify mounting and avoid expensive machining of the shaft because the inner ring shoulder is an excellent counterface.



Fig. 6

Axial shaft seals

Features

- Unique all-rubber (both NBR and FKM) seals for rotating shafts
- Seals axially against a stationary counterface

Benefits

- Combines positive lip contact with centrifugal flinger action
- Reduces installation time, can be stretched and installed over flanges and bearing housings without costly dismantling
- Reduces shaft machining cost and application space

Features

- Deep groove ball bearing with a radial shaft seal
- SKF waveseal design

Benefits

- Compact unit saves space
- Simple and quick mounting
- Effective sealing
- Reduce total cost

Axial shaft seals (V-rings)

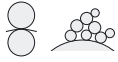


A V-ring (→ fig. 6) is an all-rubber seal that seats directly on the shaft and seals axially against the counterface of a housing, seal case or similar surface.

Designed with a body and a long, flexible conical shaped sealing lip with an integral resilient hinge, the seal acts like an axial flinger. These seals have excellent lubricant retention properties and are highly effective at excluding contaminants. V-rings can be used as the primary seal or as a secondary, back-up seal.

Because it is all rubber and very elastic, a V-ring can be stretched over flanges or other assemblies during installation, thereby reducing the need to dismantle an entire assembly. V-rings perform well in dry environments and are capable of accommodating a greater amount of eccentricity and misalignment than most radial lip seals.

Labyrinth and gap-type seals



Labyrinth seals (→ **fig. 7**) and gap-type seals are non-contact seals that are typically used when space is limited, and operating conditions require low heat generation due to friction and minimum wear of mating components. These seals are usually designed in close cooperation with customers to meet specific application criteria. During the engineering phase, this type of sealing solution requires special attention to the ingress of contaminants into the bearing cavity.

A good example of a gap-type seal design that was developed based on customer requirements is the seal used in oscillating bearing units (→ **fig. 8**).

Benefits

- Non-contact seal
- No heat generated by the seal
- Avoids seal grooves on the shaft
- Meets special operating and application requirements

O-rings

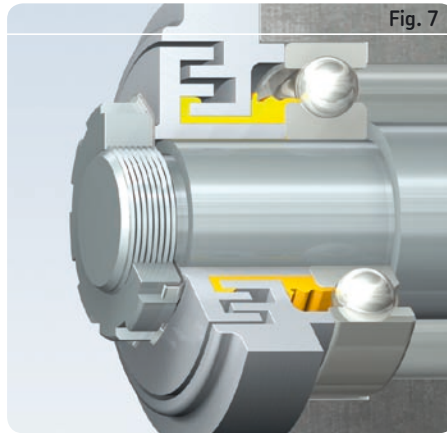


O-rings (→ **fig. 9**) are one of the most common static sealing devices. They are used to seal against fluid or solid contaminants in static applications between stationary surfaces or in applications where there are reciprocating movements.

A good example of an O ring as a reciprocating seal is the printing cylinder bearing unit (PCU) where an O-ring seals the needle roller bearing, which is mounted between an intermediate eccentric ring and the outer ring. (→ **fig. 23 on page 12**)

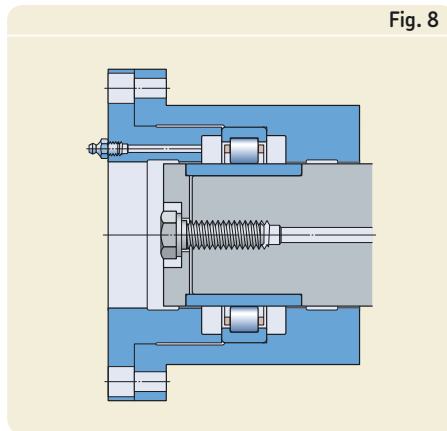
Benefits

- Simple design
- Easy to install and replace
- Wide range of sizes and choice of materials



Labyrinth seal

Gap-type seal in an oscillating bearing unit (OBU)



Wear sleeves



Excessive dirt, and lack of lubricant are the primary causes for a seal to wear a groove in a shaft to create a leak. When a seal groove reaches the point where a new seal will not compensate for the damage, there are only two options: replace/repair the shaft or install a SPEEDI-SLEEVE. (→ **fig. 10**).

SPEEDI-SLEEVE wear sleeves are the cost-effective alternative to resizing, metalizing or replacing damaged shafts. Unlike conventional wear sleeves that add bulk to the shaft, the ultra-thin SPEEDI-SLEEVE does not require an oversized seal or other modifications. When installed properly, these cost-effective sleeves provide a snug, leak-proof fit.



O-rings

SPEEDI-SLEEVE



Features

- Thin-walled, hardened sleeve with appropriate surface roughness
- High quality surface excellent for shaft seals

Benefits

- Simple, reliable and cost-effective
- Eliminates expensive shaft rework
- Quick and easy to install

For additional information see the SKF Wear sleeves catalogue or the SKF Interactive Engineering Catalogue.



Mechatronics

The area of mechatronics brings mechanics and electronics together to solve age-old mechanical problems with the latest technology. Using this technology, SKF mechatronic solutions can integrate sensors and software with either single components, or complete mechanical systems, to create innovative, environmentally friendly solutions for the printing industry.

Oscillating drive system (ODS)



In many industrial applications there has been a gradual tendency toward electro-mechanical actuation and away from mechanical, hydraulic and pneumatic actuation

The oscillating drive system (→ **fig. 1**) is an actuator solution that drives oscillating rollers for inking and dampening in printing presses. These rollers must oscillate axially as they rotate so that ink and dampening fluid can be transported and distributed evenly as the press operates. With an ODS, rotational speed, oscillating frequency and stroke length can be adjusted and controlled independently to provide greater machine flexibility.

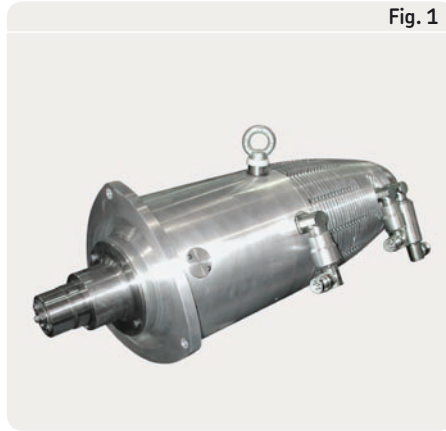
Features

- Direct drive and control system consists of motors, encoders, rolling bearings, seals, ball screw
- Rotational speed, oscillating frequency and stroke length can be adjusted and controlled independently

Benefits

- Improved flexibility for small production runs
- Shorter make-ready times
- Less paper waste
- Easy and quick mounting and dismounting
- Reduced maintenance

Fig. 1



Oscillating drive system (ODS)

Servo drive units – Scandrive series



Based on its innovative and patented design of reduction gears, SKF develops and manufactures components for printing presses aimed at improving the quality of colour printing.

Characteristics

- Reduction ratio in one step up to 250:1
- Low backlash, typically less than 1 min of arc
- Output torque: 1,5 Nm to 14 500 Nm
- Input power: 5W to 10 kW
- High acceleration with modest motor input power due to the low inertia of the input shaft
- Extremely compact design
- High stiffness owing to non-deflecting design and multiple-meshing teeth
- Maintenance-free

Register units



Bright, sharp colour printing at high speed requires precision positioning of the ink on paper. Adjusting the sidelay, circumferential or diagonal (cocking) position of a printing cylinder within 1/100 mm, despite vibration from the press, is a critical operation.

Scandrive series register units are designed and built for exactly this purpose. High resolution, minimal backlash and high stiffness are the primary features of these units. In addition to single registers (→ **fig. 3**) used for adjusting either sidelay, circumferential or cocking position, a double register, that combines two separate register movements, is also available (→ **fig. 4**).

Features and benefits

- Position feedback via a potentiometer or an inductive gauge indicates the zero position
- Customized solutions available
- Robust stepper motor, shielded from oil, dust and electromagnetic interference
- Distinct mechanical end stops (prevent jamming if accidentally run outside the range)
- Synchronous or asynchronous motors available
- 2-function actuator for separate sidelay and circumferential registration to each of the two halves of the shell plate cylinder in double-width presses optionally available
- Delivered as ready-to-install unit
- Supports "zero error" production

Self-oscillating rollers



Printers today demand true versatility from their press investments. Running newspapers at night is followed by commercial printing during the day. Making the switch from one type of paper to another can require very different settings. The switch also brings different challenges. One of those challenges that is typically found on a 4-colour web press is ghosting. Ghosting can occur for a number of reasons. However, when the primary cause is build-up on the blanket, SKF has a solution – The Scandrive R 55 and the Scandrive R 84.



Fig. 3

Scandrive single register unit



Fig. 5

Scandrive self-oscillating roller (single circumference)



Fig. 4

Scandrive double register unit



Fig. 6

Scandrive self-oscillating roller (double circumference)

Scandrive R55 (single circumference → **fig. 5**) and Scandrive R84 (double circumference → **fig. 6**) are built to correct this problem. The Scandrive R55 and Scandrive R84 units are designed to be the core of a self-oscillating form or rider roller on high-speed web offset presses. The pure sinusoidal axial oscillation needed to rub out the ink or water is generated entirely inside the Scandrive R55 and Scandrive R84 units.

Benefits

- Easy to add on existing presses
- Offers the possibility to eliminate external reduction gears and crank or cam follower mechanism
- Suitable for high operating speeds
- Different oscillating frequency ratios and various strokes available, customized designs on demand
- Enhanced print quality
- Reduces ghosting
- Calm motion
- Totally self-contained

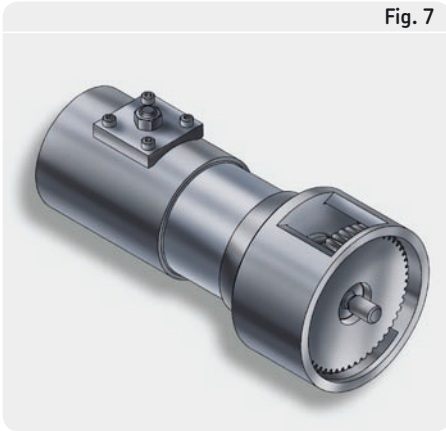


Fig. 7

Scandrive external oscillator

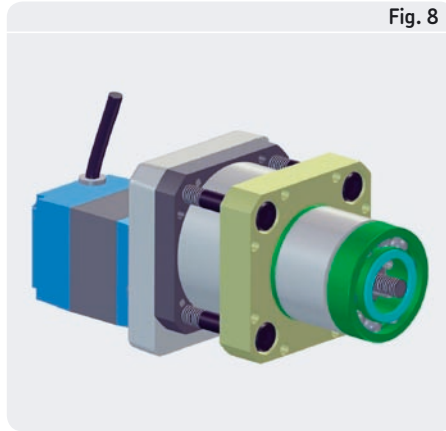


Fig. 8

Scandrive ductor drive unit

External oscillators



Traditionally oscillators are driven by the main press drives through worm gears and cranks. This places great limitations on the layout of modern presses and takes up valuable space. It also requires a large oil bath. Also the oscillators need to be located on the drive side.

SKF's external oscillator (→ fig. 7) overcomes all these problems. The design is based on SKF's proven eccentric gears which provide very high reduction ratios, plus a follower in a deep, precision milled, sinusoidal track.

Features and benefits

- Compact unit easy to install
- Self-contained unit independent of the drive system
- Installation possible on operator side or drive side
- "Sealed for life" mechanisms.
- Different reduction ratios and stroke lengths available, customized designs on request
- Oil or grease lubrication possible

Ductor drive unit



Speed control of the ductor roller is important in modern printing presses and justifies a separate speed controller. By default the roller follows the press speed proportionally. When a correction of the ink density across the full web width is required, the most convenient solution is to adjust ductor speed, rather than adjusting all the ink keys.

In some cases the press designer may specify a curvilinear ductor speed/press speed ratio. In many situations mechanical drives direct from the main motor are no longer adequate.

SKF's Ductor drive unit Scandrive V30 (→ fig. 8) provides the complete solution to this problem.

Features and benefits

- Compact, sealed and ready-to-install unit
- Unit contains a brushless DC motor, speed reducer and an integrated controller
- Integrated encoder delivers a speed feedback signal to the press control system

Linear motion offer portfolio









The requirements on linear motion solutions for the printing industry vary widely. However, the broad assortment of SKF's standard products can meet most of the printing industry's need to drive, guide and position. The wide assortment, availability and customer support make SKF linear solutions "Easy to buy".

The product range includes

- actuation systems (linear and rotary actuators)
- ball and roller screws
- guiding systems (shaft guidings incl. linear ball bearings, precision and profile rail guides, slides)
- tables and positioning systems
- spindles.

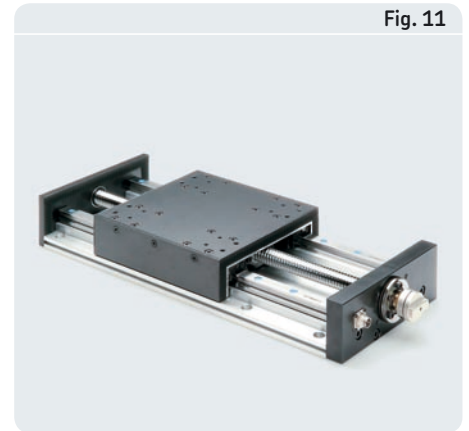
For additional information, contact your local SKF representative or visit the website www.linearmotion.skf.com.

Examples where linear motion products are used

- Linear actuators used for tilting the ink fountain when changing colours (→ **fig. 9**) 
- High-precision ground ball screws used for accurate positioning during plate making process (→ **fig. 10**) 
- Profile rail guides used for adjustment of turner bars (→ **fig. 11**) 
- Linear actuators with a potentiometer to control the position used for the chuck movement in a reel stand (→ **fig. 9**) 
- Preloaded ball screws for positioning the printing cylinders in a flexographic printing machine, guided by profile rail guides and precision rail guides (→ **fig. 10**) 
- Precision rail guides and magnetic bearings used for moving the computer to plate (CtP) system (→ **figs. 12 and 13**) 



Linear actuator



Profile rail guide slides



Ball and roller screws



Rail guides



Magnetic bearing



Fig. 14

Spandau pumps

VOGEL Spandau pumps



With Spandau pumps from Vogel, (a member of the SKF Group) SKF can offer manufacturers high-pressure pumps and sealless immersion pumps (→ **fig. 14**) for a wide range of applications found in the printing, finishing, converting and packaging industries.

These quiet, smooth running pumps can accommodate dirty environments as well as extremely hot or cold fluids. Their compact, space saving design provides a high degree of efficiency and reliability within a compact envelope. Spandau pumps are available standard or they can be designed to meet the needs of a specific application. Quick installation and dismantling enable easy cleaning and reduced maintenance costs. Their greatest advantage is that they can be used to pump liquids containing particulates and there is no danger if these pumps are run dry.

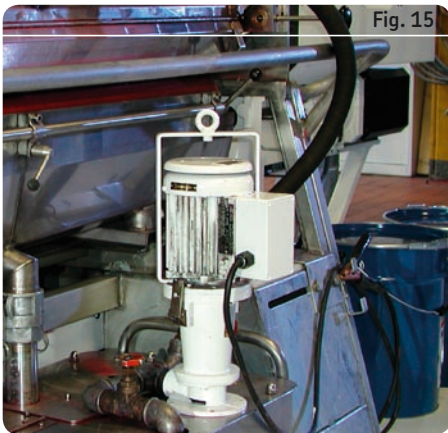


Fig. 15

Centrifugal pump for ink

Centrifugal pumps for ink

These pumps (→ **fig. 15**) are typically used in rotogravure and flexographic presses. They are also used on presses used to print magazines, packaging material, foil and other flexible materials, envelopes, playing cards, wrapping paper and wall paper.

Benefits

- Circulates ink in a closed loop system (reservoir-press-reservoir)
- Delivers a constant flow without pulsations
Can accommodate highly viscous, special solution inks
- Minimal heat transfer to the ink
- Customized solutions – flexible or permanent built-in solutions



Fig. 16

Centrifugal pump with open impeller

Centrifugal pumps with an open impeller

Characteristics

- Submersible pump fits in the tank, to save space (→ **fig. 16**). Easy to install
- Sealless design, reduced need for maintenance – lower operating cost
- Discharge is placed above the reservoir for fast, easy connections
No additional connections through the reservoir lid are necessary
- Stainless steel version, easy to handle during ink change



Offline instruments



SKF Asset Efficiency Optimization



Online monitoring

Services

Our complete offering of world-class services and technologies are combined and delivered through our SKF Asset Efficiency Optimization process.

Integrated solutions

Our extensive range of hardware and software components have been designed to work together – with each other, and with your facility's computerized maintenance management system (CMMS). And one common software platform enables collaboration between your maintenance, operations and reliability teams.

Online systems

Our on-line systems are excellent for continuous monitoring of critical plant equipment or equipment where access is difficult, or where user safety is at risk.

Portable systems

Our portable monitoring solutions enable maintenance personnel to identify on the spot problems, and collect dynamic machine data that can be analysed offline using our SKF @ptitude Monitoring Suite of software products.

Software

Consisting of three modules – Analyst, Inspector, and Observer – the SKF @ptitude Monitoring Suite forms the basis for a completely integrated approach to condition monitoring. With a familiar Windows™ interface, this powerful software accepts data from the full range of SKF data collection devices and interfaces with SKF @ptitude Decision Support to facilitate consistent and reliable decision-making.

Scaleable

Whatever the size of your operations or the scope of your requirement, SKF can provide the right solution for you. And our solutions can be expanded as your needs develop.

Entry level condition monitoring

SKF offers a range of basic products designed for the user who wishes to begin a low-cost condition monitoring programme. Basic instruments assess and report on temperature, oil condition, speed, bearing condition, shaft alignment, noise, vibration and more.

Complete asset management solutions

Our solutions can meet the needs of the most sophisticated printing system, including consultancy services, custom solutions, 24/7 online monitoring and protection systems integrated with leading edge portable instruments for machinery and process data collection, and even wireless data collections and remote web-based monitoring.

Comprehensive

By delivering consultancy, services, maintenance and reliability programmes – combined with our world-class technologies – our comprehensive solutions make sure you get the best from your printing machinery.

Machine Support



Machine Support is a dedicated engineering service organization, which has been in operation for over 20 years. At present, the group consists of three companies with a wide network of affiliated dealers and services. During many successful years of operation, the company has developed a reputation of excellence in laser alignment services (→ **fig. 1**) and mounting solutions for different industries e.g. the printing industry.

Optimal alignment and correct mounting are equally vital in printing machinery to perform well over extended periods. Correct installation not only means good product quality but often reduced energy consumption as well.

Machine Support's long background of practical experience enables them to offer the best solution to alignment problems. The use of advanced laser alignment equipment (→ **fig. 2**) provides the highest standards of accuracy to be achieved in the shortest possible working time. Machine Support specializes in geometric alignments such as measuring the parallelism of machine rollers and presses. Also, for example, measurement services to measure parallelism and distances can be offered.

This broad range of alignment services, along with the use of the latest mounting techniques, give the company a unique niche in its industry sector.

For more information, please visit www.skf.com or www.machinesupport.com.

SKF Engineering Consultancy Service (ECS)



Working together with SKF Engineering Consultancy Services (ECS), the time to market for the next series of printing machinery can be reduced, making it more likely that machinery performance meets expectations. ECS engineers follow well-proven SKF processes for design optimization and verification as well as troubleshooting. These processes involve a systems approach and close cooperation. This, together with unique tools and competencies in dynamic simulations, material science and lubrication results in getting the right design from the beginning.

Fig. 1



Laser alignment mounting service

Fig. 2



Laser alignment equipment

How can Engineering Consultancy Service support?

It always starts by getting a clear understanding of customer needs early in a project. Only after that is done can ECS help to identify potential design improvements and solution products.

- Design optimization: ECS can help to evaluate ideas at an early stage when all options are still open. This team of experienced engineers can conduct innovative concept studies, run virtual application tests using proprietary SKF software or build and test solutions on "intelligent" test rigs. They can also conduct lubrication studies to evaluate lubricants for unique application requirements.
- Design verification: ECS can help to suggest test strategies to validate designs. Performance evaluation of tested components in a prototype or modelling parts of printing machinery with proprietary SKF simulation tools. Most importantly, ECS understands the results of these tests and can provide reliable recommendations.
- Troubleshooting: Customers can count on the ECS engineering team for expertise in component failure analysis. The approach combines theoretical analysis with material science and experience gained from similar applications. The results provide reliable solutions to a recurrent problem.

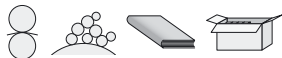
The Engineering Consultancy Service toolbox

- Advanced calculations: Use proprietary SKF software, to analyse bearing, shaft and housing systems as well as complete structures using the finite element method (FEM) (→ **fig. 3**).
- Dynamic solutions: Use proprietary calculation tools, to analyse dynamic system behaviours like noise and vibration levels (→ **fig. 4**).
- Lubrication engineering: Use test rigs to simulate real operating conditions to determine oil film thickness, wear properties of the lubricant, micro pitting behaviour and the lubricant delivery system, but also consult on lubrication selection.
- Material analysis: Utilize metallurgical competence and use special equipment like scanning electron microscopes or X-ray analysis to determine, for example, residual bearing life.
- Electrical analysis: Identify symptoms and root cause of current bearing leakage and recommend counteractions.

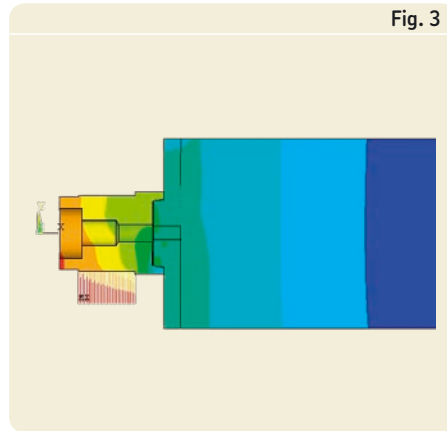
Accessories

SKF has a wide assortment of accessories, including gauges and tools, to make mounting components faster, easier and more accurate.

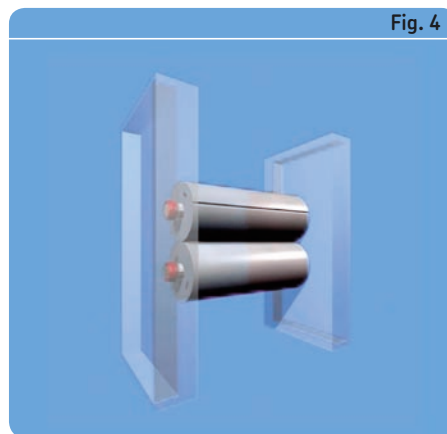
Lock nuts



SKF supplies lock nuts (→ **fig. 5**) in a wide range of sizes. They are used to locate bearings and other components onto shafts as well as to facilitate mounting and dismantling on tapered journals. They provide reliable locking for maximum bearing service life and can prevent bearing fitting damage. Precision lock nuts for very precise applications are also available.



Analysing a printing cylinder using FEM



Dynamic analysis for vibration of a print cylinder couple

Gauges



SKF has developed a range of gauges to check tapered shaft journals or the radial internal clearance of cylindrical roller bearings. They are designed to meet the requirements of high-precision applications.



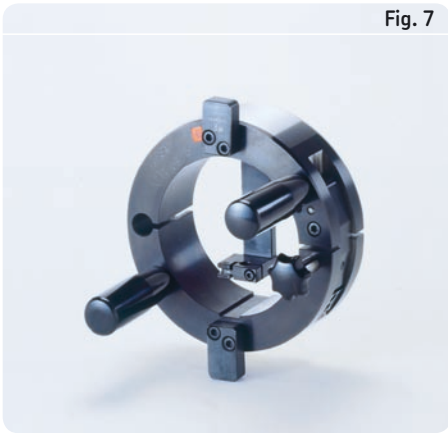
High-precision lock nuts



GB 30 series internal clearance gauge

GB series internal clearance gauges

Conventional measuring methods and instruments are not always suitable to measure the inside or outside envelope diameter of the roller set of a cylindrical roller bearing. Therefore, SKF has developed GB 30 (→ **fig. 6**) and GB 49 (→ **fig. 7**) series gauges specially designed to take accurate measurements that are necessary when mounting high-precision cylindrical roller bearings with a tapered bore.



GB 49 series internal clearance gauge



HKM internal clearance gauge



DMB series taper gauge

HKM radial internal clearance gauge

The HKM radial internal clearance gauge (→ fig. 8) was developed to measure radial clearance when replacing a printing cylinder bearing unit (PCU). When an HKM gauge is used, the printing cylinder does not need to be removed as would be typical.

Ring gauges, taper gauges

Gauges to check a tapered shaft seating are available in different executions. Ring gauges in the GRA 30 series (→fig. 9), taper gauges in the 9205 series (→ fig. 10) or taper gauges in the DMB series (→ fig. 11) are available for 1:12 and 1:30 tapers. For additional information about gauges, see www.skf.com.

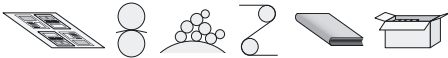


GRA 30 series ring gauge



TIH 030m induction heater

Tools for mounting and dismounting



SKF maintenance tools are designed to optimize mounting and dismounting bearings. As part of the entire SKF Maintenance Products assortment, a variety of mechanical tools, heaters (→ fig. 12) and hydraulic tools (→ fig. 13) (oil injection equipment) are available.

For more information, see www.skf.com and www.mapro.skf.com.



9205 series taper gauge



TMJL 50 hydraulic pump

Lubrication systems

Proper lubrication is essential for maximum bearing service life

Friction inside a bearing is created when two contact surfaces are in relative motion without an adequate lubricant film to separate them. In most industrial applications, the lubricant is grease or oil. However, there are applications that use other media as a lubricant. In addition to reducing friction, mineral oil based lubricants prevent wear and corrosion and, in some cases, help protect the application from the ingress of contaminants.

In a bearing, the oil film between the rolling elements and raceways can range in thickness from one-tenth of a micron to 1 micron. For such a thin film of lubricant to be effective, the type of lubricant and the lubricant delivery system must be selected carefully, taking a number of variables into account. Some of these variables include, but are not limited to the following

- bearing type
- bearing size
- loads
- application speed
- operating temperature
- vibration levels
- operating environment.

Not only does the appropriate lubricant need to be selected. The reliable transport of the lubricant to the lubrication position is also of vital importance.

SKF today offers different lubrication systems, selected and engineered by experts to meet specific application requirements. This also includes also lubrication demands.

Grease lubrication



Grease can be used to lubricate rolling bearings under normal operating conditions in the majority of applications.

Grease has an advantage over oil in that it is more easily retained in the bearing arrangement, particularly where shafts are inclined or vertical, and it also contributes to sealing the arrangement against contaminants, moisture or water.

Excessive amounts of grease will cause the operating temperature within the bearing to rise rapidly, particularly when running at high speeds. As a general rule, when starting up, only the bearing should be completely filled, while the free space in the housing should be partly filled with grease. Before operating at full speed, the excess grease in the bearing must be enabled to settle or escape during a running-in period. At the end of the running-in period, the operating temperature will drop considerably, indicating that the grease has been distributed in the bearing arrangement.

However, where bearings are to operate at very low speeds and good protection against contaminants and corrosion is required, it is advisable to fill the housing completely with grease.

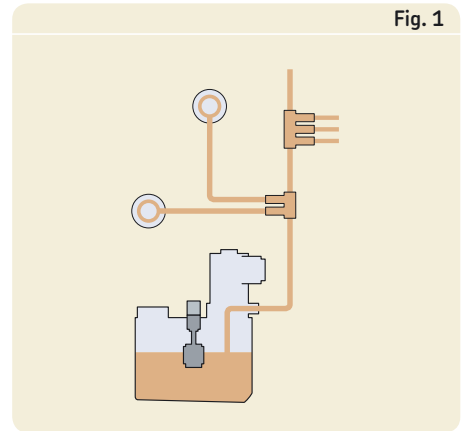
Oil lubrication

Oil is generally used for rolling bearing lubrication when high speeds or operating temperatures preclude the use of grease, when frictional or applied heat has to be removed from the bearing position, or when adjacent components (gears etc.) are lubricated with oil.

To increase bearing service life, all methods of bearing lubrication that use clean oil are preferred, i.e. well filtered circulating oil lubrication, oil jet method and the oil-spot method with filtered air and oil.

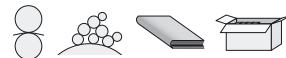
When using the circulating oil and oil-spot methods, adequately dimensioned ducts must be provided so that the oil flowing from the bearing can leave the arrangement.

Fig. 1



Vogel centralized lubrication system

VOGEL lubrication systems



Vogel (a member of the SKF Group) is the world leader in the field of centralized lubrication systems for industrial applications and rail vehicles. One industry in which they are a very strong player is the printing and converting industry.

Centralized lubrication systems (→ fig. 1) are used to deliver lubricant from a central source to various points on a machine. These systems can be used to relubricate gear drives, bearings, chains and any other machine components. VOGEL centralized lubrication systems require practically no maintenance. Servicing is limited to topping off the lubricant reservoir and occasionally inspecting the connections at each of the lubrication points.

Vogel designs and manufactures a full line of progressive lubrication systems, single-line lubrication systems or oil circulation systems like those typically found on printing presses.



Gear drives

The gear drives typically found on printing presses, folders and converting machines place a number of requirements on the lubricant and lubricant delivery system. In addition to reducing friction between mating gears, the lubricant must be able to reduce gear temperatures and keep contaminants from damaging the gears.

To meet these requirements, gear drives generally require circulating oil systems. These systems, which are available through Vogel, are designed and manufactured to exacting specifications so as to meet the specific needs of the application.

Circulating oil systems

Circulating oil systems (→ **figs. 2** and **3**) are used where an uninterrupted flow of oil is required for lubrication or cooling purposes. The oil is supplied by a gear, rotor, vane or piston pump and then portioned out. The lubricant is optimally fed to various points in metered quantities.

Benefits

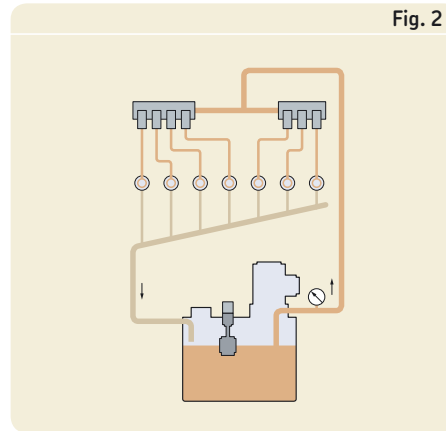
- Reduces heat and filters lubricant
- Reliably lubricates bearings and gears
- Delivers large volumes of lubricant

Applications

- Bearings and gears in big sheet fed offset and web offset presses
- Small gearboxes for stand alone drives
- Folders for web and gravure presses

System components

- Gear, rotor or piston pump
- Metering unit (e.g. volume limiter, progressive feeder)
- Filter
- Additional components (e.g. valves, cooler, water sensor)



Circulating oil system



Circulating oil system

Bearings

Bearings generally require a precisely metered quantity of lubricant. VOGEL delivers single line systems as well as progressive systems for lubrication solutions. Oil or fluid grease can be used as a lubricant. VOGEL has developed a strong customer base among printing and converting machine manufacturers. End users rely on the high product quality of VOGEL products.

Single-line lubrication systems for oil and fluid grease

Single-line lubrication systems (→ **fig. 4**) are used to supply relatively small amounts of lubricant to replace precisely the amount consumed. They work on an intermittent basis. Distribution is done with single-line distributors (→ **fig. 5**).

Benefits

- Lubrication not only for bearings but also for chains, cam followers and gears with light loads
- Precisely metered quantity of lubricant (0,01 – 1,5 cm³)
- Flexible lay-out of lubrication system

Applications

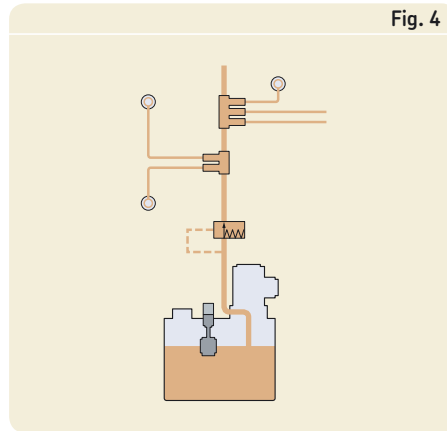
- Web, sheet fed, flexo and gravure presses
- Converting machines

System components

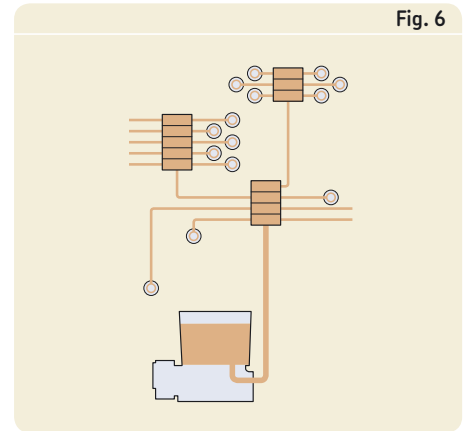
- Gear or piston pump
- Single line distributors
- Pressure switch

Progressive lubrication systems for oil or grease

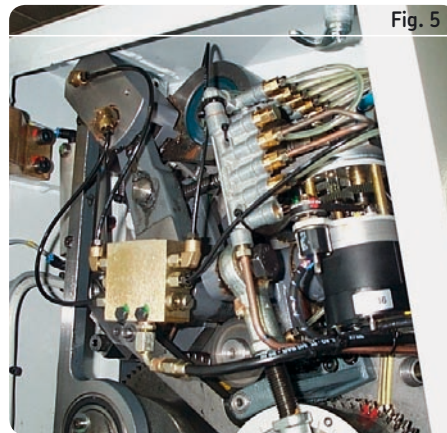
In a progressive lubrication system (→ **fig. 6**), the lubricant is precisely metered and delivered to each of the lubrication points, which can include bearings, gears and chains. This is done directly by a master feeder or indirectly via secondary feeders (→ **fig. 7**).



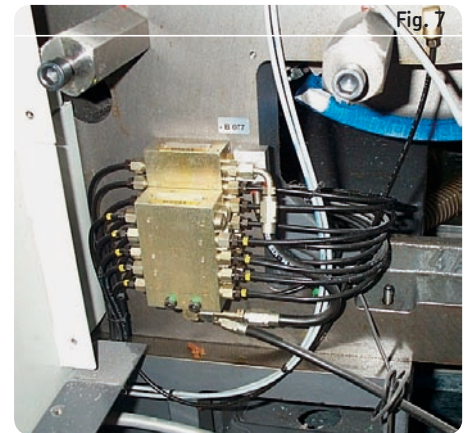
Single-line lubrication system



Progressive lubrication system



Single-line distributor



Progressive feeder

Benefits

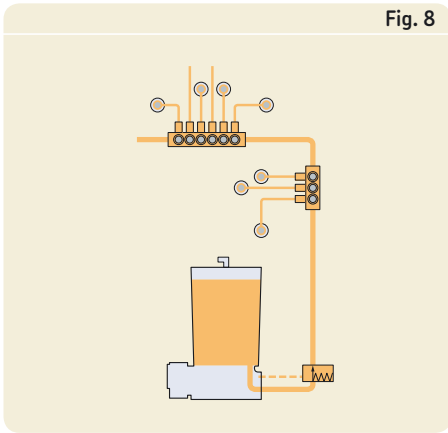
- Can be used for all lubricants (up to grease NLGI 2)
- Good monitoring capability
- Can be used for both oil circulating and total loss systems

Applications

- Printing presses
- Converting machines

System components

- Piston pump
- Progressive feeder



Single-line lubrication system



Single-line distributor

Special applications

In close cooperation with its customers, VOGEL has developed a unique solution of lubrication systems for the delivery chains on sheet fed presses, transport chains in die cutters and small gear drives on mobile folders.

Innovation

The latest innovation of Vogel automatic lubrication systems is the single-line system for grease. Flexible layout and low stress on grease are the main characteristics of this lubrication system.

Single-line grease lubrication systems

Single-line grease lubrication systems, which work on an intermittent basis, are used to replenish small amounts of grease (→ fig. 8). These systems use single-line distributors with an optical control (→ fig. 9).

Benefits

- Total loss system for grease up to NLGI 2
- Very low risk of oil separation of grease
- Precisely metered quantities of lubricant
- Good sealing function in combination with grease NLGI 2
- Flexible and modular layout

Applications

- Sheet fed offset and web presses
- Drive and operator sides

Designation suffixes

The following bearing designation suffixes can be found in this catalogue.

A	Deviating or modified internal design with the same boundary dimensions. As a rule, the significance of the letter is bound to the particular bearing or bearing series	DB	Two single row deep groove ball bearings, single row angular contact ball bearings or single row tapered roller bearings matched for mounting in a back-to-back arrangement. The letter(s) following the DB indicate the magnitude of the axial internal clearance or preload in the bearing before mounting. For paired tapered roller bearings, the design and arrangement of the intermediate rings between the inner and/or outer rings are identified by a two-figure number which follows immediately after DB A Light preload (angular contact ball bearings) B Preload greater than A (angular contact ball bearings) GA Light preload (deep groove ball bearings) GB Preload greater than GA	GB	Single row angular contact ball bearing for universal matching in a back-to-back or face-to-face arrangement; when mounted, the bearing pair will have a preload greater than GA
ACD	High-precision single row angular contact ball bearing, 25° contact angle, optimized internal design	DF	Two single row deep groove ball bearings, single row angular contact ball bearings or single row tapered roller bearings matched for mounting in a face-to-face arrangement. Supplementary designations for axial internal clearance and preload are explained under DB	K	Tapered bore; taper 1:12
ACE	High-precision single row angular contact ball bearing, 25° contact angle, optimized internal design, small size balls for very high speed and rigidity	DG	Two single row angular contact ball bearings for universal pairing, i.e. paired for mounting in a back-to-back, face-to-face or tandem arrangement. Supplementary designations for axial internal clearance and preload are explained under DB	P	Moulded cage of glass fibre reinforced polyamide 6,6
B	Deviating or modified internal design with the same boundary dimensions	E	Modified internal design with the same boundary dimensions; as a rule the significance of the letter is bound to the particular bearing or bearing series; usually indicates reinforced rolling element complement	PA9A	Dimensional and running accuracy according to ISO tolerance class 2, resp. ABMA tolerance class ABEC 9
BE	Single row angular contact ball bearing, 40° contact angle, optimized internal design	FB	High-precision single row angular contact ball bearing, 18° contact angle, optimized internal design	P4A	Dimensional accuracy to ISO tolerance class 4 and running accuracy to ABMA tolerance class ABEC 9
C	Deviating or modified internal design with the same boundary dimensions. As a rule, the significance of the letter is bound to the particular bearing	GA	Single row angular contact ball bearing for universal matching in a back-to-back or face-to-face arrangement; when mounted, the bearing pair will have a light preload	RS1	Acrylonitrile-butadiene rubber seal with sheet steel reinforcement, on one side of the bearing
CB	Single row angular contact ball bearing for universal matching in a back-to-back, face-to-face or tandem arrangement. When arranged back-to-back or face-to-face, there will be Normal axial internal clearance prior to mounting			RSL	Low-friction acrylonitrile-butadiene rubber seal with sheet steel reinforcement, on one side of the bearing
CC	C design spherical roller bearing but with enhanced roller guidance and correspondingly reduced friction			RSH	Acrylonitrile-butadiene rubber seal with sheet steel reinforcement, on one side of the bearing
CD	High-precision single row angular contact ball bearing, 15° contact angle, optimized internal design			RZ	Low-friction acrylonitrile-butadiene rubber seal with sheet steel reinforcement, on one side of the bearing
CE	High-precision single row angular contact ball bearing, 15° contact angle, optimized internal design, small size balls for very high speed and rigidity.			2RS1	RS1 seal on both sides of the bearing
CL7C	Tapered roller bearing for precision applications			2RSL	RSL seal on both sides of the bearing
				2RSH	RSH seal on both sides of the bearing
				2RZ	RZ seal on both sides of the bearing
				SP	Special precision class, dimensional accuracy approximately to ISO tolerance class 5 and running accuracy approximately to ISO tolerance class 4
				V	Full complement bearing (no cage)
				VAA	High-precision and preloaded spherical roller bearing
				VAB	High-precision and preloaded spherical roller bearing
				VAE	High-precision and preloaded spherical roller bearing



- VA751** High-precision and preloaded spherical roller bearing
- VA755** Additional specification for printing press bearings, special tolerances and inspections
- VA759** High-precision and preloaded spherical roller bearing
- W33** Annular groove and three lubrication holes in the outer ring
- Z** Shield of pressed steel on one side of the bearing
- 2Z** Z shield on both sides of the bearing

Application specific product assortment

For best performance

SKF manufactures a full range of different solutions suitable for a wide variety of printing applications. These products, which include bearing and bearing units, seals, lubricants and lubrication systems, mechatronics and linear motion devices, specialty products and services are available locally and globally.

In response to industry's ultimate need to produce more with less, SKF has combined its specific knowledge and experience with the latest technology to develop solutions for your specific applications.

Whether your goal is to design equipment that provides more customer value, or to increase overall profitability, with SKF experience and expertise you're likely to find a real solution.

SKF has selected application specific solutions from its comprehensive product assortment. Each product was carefully selected based on the experience of application engineers in the printing industry.

The products in this "Application specific product assortment" offer customers special solutions, which might not be found in the SKF General Catalogue or SKF Interactive Engineering Catalogue.

Benefits

- Long-term supply stability
- Worldwide availability
- Supply chain reliability
- Reduce time to market
- Reduce total cost
- Improve machine reliability

No two applications are the same. With SKF, you can rely on products and services that are designed to meet the unique demands of your application.

SKF's competence and our global presence is the base to be the best partner for the graphic arts industry worldwide.



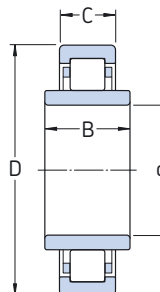


Cylindrical roller bearings for oscillating rollers

For detailed specifications contact the nearest SKF application engineering service

Bearing bore diameter, mm	Bearing bore diameter, mm									
	BC1-0160	BC1-0628	BC1-0216	BC1-0190	BC1-0809	BC1-0043	BC1-0454	BC1-0318	BC1-0318 A	BC1-0846
15										
17										
20										
25										
30										
35										
40										
45										
50										
55										
60										
65										
70										
75										
80										
85										
90										

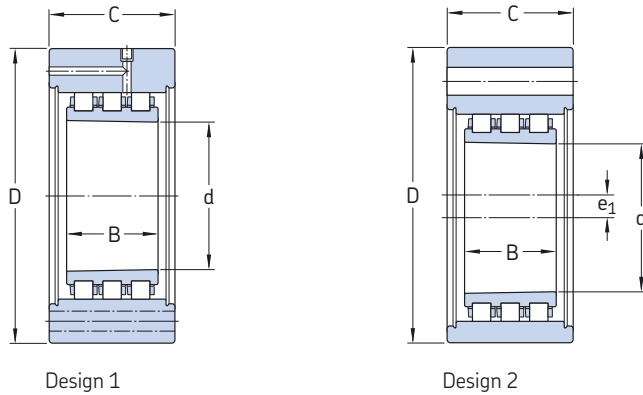
Designation	Principal dimensions				Stroke
	d	D	C	B	
-	mm				mm
BC1-0160	17	40	16	57,5	+22
BC1-0628	40	68	15	71	+30
BC1-0216	45	75	16	42	+12,5
BC1-0190	45	75	21	50	+17,5
BC1-0809	45	85	19	41	+12,2
BC1-0043	55	100	21	45	+13
BC1-0454	55	100	21	54	+17,5
BC1-0318	55	100	21	59	+20
BC1-0318 A	55	100	21	59	+21,3
BC1-0846	85	150	28	57	+16



Printing cylinder bearing units (PCU)

Designs 1 and 2

For additional information, visit [www.skf.com/Industries/Printing machines](http://www.skf.com/Industries/Printing_machines)
Below listed items only illustrate a part of the whole assortment.

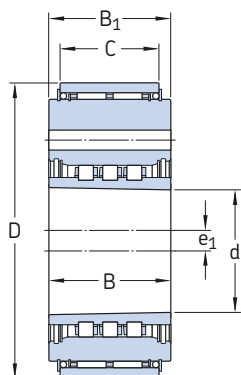


Dimensions					Designation	Design	Taper
d	D	B	C	e ₁			
mm					-	-	-
65	125	53	65,1	-	BC4B 326624	1	1:30
	130	40	70	-	BC3-7032 A	1	1:30
	160	36	52	16	BC2-7149	2	1:12
70	145	54	68	3	BC3-7043	2	1:30
	147	54	68	-	BC3-7016 B	1	1:30
75	160	60	60	-	BC2B 326773	1	1:30
	160	60	60	12,7	BC2B 326774	2	1:30
95	185	65	95	-	BC3-7014	1	1:30
	185	65	95	12,7	BC3-7013	2	1:30
	185	70	65	-	BC3-7030	1	1:30
105	150	71	71	-	BC4B 326634	1	1:30
	200	60	80	-	BC3-0001 BA	1	1:30
	200	64,5	80	-	BC2-7220 A	1	1:30
120	200	60	79	5	BC2-7189	2	1:12
125	180	100	90	-	BC4-0010	1	1:30
	258	68	94	-	BC3-7026	1	1:30
130	230	78	92	-	BC3-7040 A	1	1:30
	230	78	92	-	BC2-7221 A	1	1:30
170	235	78	88	-	BC4-7046	1	1:30
	277	78	88	5	BC4-7059 A	2	1:30
	277	78	88	5	BC4-7060 A	2	1:30
180	250	69	69	-	BC2-7124	1	-

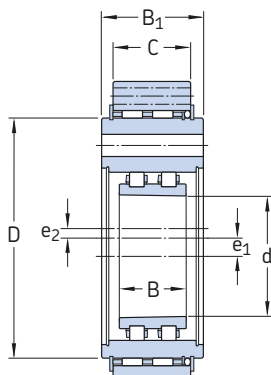
Printing cylinder bearing units (PCU)

Designs 3, 4 and 5

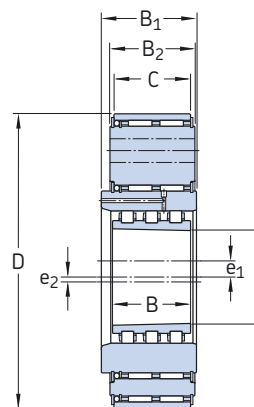
For additional information, visit www.skf.com/Industries/Printing machines
Below listed items only illustrate a part of the whole assortment.



Design 3



Design 4



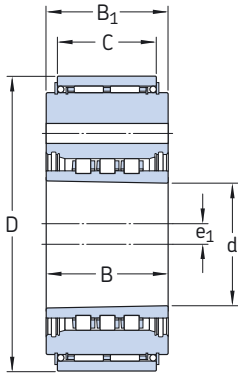
Design 5

Dimensions								Designation	Design	Taper
d	D	B	B ₁	B ₂	C	e ₁	e ₂			
mm										
50	120	23	70	–	42	4	–	BVT-7126	3	1:12
65	142	53	65,1	–	52	3,5	–	BVTB 326625 C	3	1:30
	142	53	65,1	–	52	3,5	–	BVTB 326625 CC	3	1:30
	142	53	65,1	–	52	3,5	–	BVTB 326625 CD	3	1:30
	150	40	55	–	48	10	–	BCT-0003 A	3	1:30
	150	40	70	–	48	10	–	BVT-7104 A	3	1:30
	150	53	65,1	–	52	7	–	BVTB 326627 AA	3	1:30
	160	36	56	–	52	16	–	BVT-7026 B	3	1:12
	180	40	101	–	60,5	7	12	BVT-7105	4	1:30
	180	36	56	52	51,8	12	3	BVN-7035	5	1:12
	205	53	65,1	59,5	52	7	14	BVNB 326628 A	5	1:30
70	205	53	65,1	59,5	52	3,5	14	BVNB 326626 C	5	1:30
	147	54	68	–	58	4	–	BVT-7047	3	1:30
	150	54	68	–	58	4	–	BVT-7127 A	3	1:30
	156	54	68	–	48	9	–	BVT-7048 C	3	1:30
	200	54	100	62	47	10	9	BVN-7053	5	1:30
75	180	60	60	–	52	12,7	–	BVTB-326772 A	3	1:30
95	205	65	95	–	58	12,7	–	BVT-7029 A	3	1:30
	205	70	65	–	58	8	–	BVT-7103	3	1:30
	270	65	95	70	54	12,7	12,7	BVN-7057	5	1:30
100	200	53,5	75,5	–	53	6	–	BVT-7035 B	3	–
	200	53,5	75,5	–	53	6	–	BVT-7038 B	3	–
	260	53,5	70,5	58	53	10	3,5	BVN-7041 B	5	–
	260	53,5	70,5	58	53	10	3,5	BVN-7042 B	5	–
105	240	60	80	–	68	12,7	0,5	BCT-7002 DA	4	1:30
	257	60	88	62	50	10	9	BVN-7063	5	1:30
	270	80	60	–	67	24	–	BVT-7056 A	3	1:30

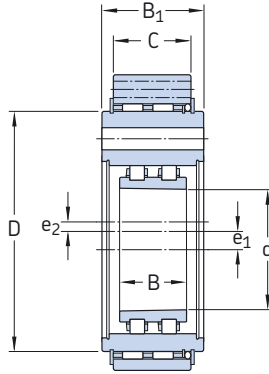
Printing cylinder bearing units (PCU)

Designs 3, 4 and 5

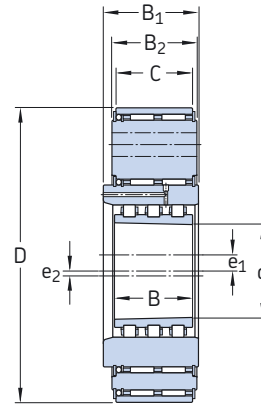
See SKF brochure Dd 7977 "The new printing performance standard" for detailed information
Below listed items only illustrate a part of the whole assortment.



Design 3



Design 4



Design 5

Dimensions								Designation	Design	Taper
d	D	B	B ₁	B ₂	C	e ₁	e ₂			
mm								-	-	-
120	260	60	79	-	60	20	-	BVT-7092	3	1:12
	320	55	75	68	67,8	30	5	BVN-7037	5	1:12
125	258	68	94	-	66	4	-	BVT-7099	3	1:30
130	290	78	97	-	64	20	1	BVT-7125 A	4	1:30
	290	78	97	-	64	20	1	BVT-7148 A	4	1:30
170	310	78	88	-	66	8,5	-	BVT-7078 A	3	1:30
	310	78	88	-	66	8,5	-	BVT-7084 A	3	1:30
	310	78	88	-	66	12	-	BCT-7001	3	1:30

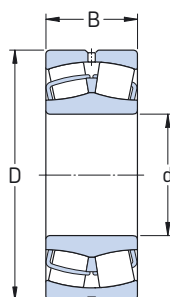
High-precision and preloaded spherical roller bearings

For detailed specifications contact the nearest SKF application engineering service

Bearing bore diameter, mm	Bearing size										
	231 ■ CCK/VA759	231 ■ VAA	232 ■ CCK/VA759	222 ■ CCK/VA759	222 ■ EK/VA751	222 ■ EK/VA759	222 ■ VAE	223 ■ CCK/VA759	223 ■ CCK/VA755	223 ■ EK/VA751	223 ■ EK/VA759
20											04
25											05
30											06
35											07
40											08
45											09
50											10
55											11
60											12
65											13
70											14
75											15
80											16
85											17
90											18
95											19
100											20
105											21
110											22
120											24
130											26
140											28
150											30
160											32

For detailed specifications contact the nearest SKF application engineering service

Bearing bore diameter, mm	Bearing size													
	450918 C	453538	467964	467304	466915 C/W33	458681	467418 C	466144 C/W33	468603 C	468043 CA/W33	454548	466816 C/W33	466817 C/W33	466713
20														
25														
30														
35														
40														
45														
50														
55														
60														
65														
70														
75														
80														
85														
90														
95														
100														
105														
110														
120														
130														
140														
150														
160														



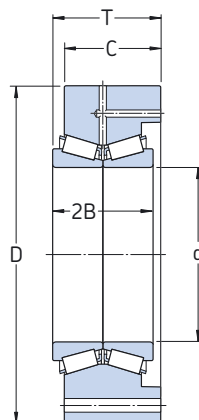
Designation	Principal dimensions		
	d	D	B
-	mm		
450918 C	45	100	36
453538	50	90	23
467964	50	110	40
467304	70	150	51
466915 C/W33	75	160	55
458681	85	150	36
467418 C	90	160	40
466144 C/W33	110	180	56
468603 C	110	200	53
468043 CA/W33	110	200	69,8
454548	130	210	64
466816 C/W33	130	230	80
466817 C/W33	140	250	88
466713	150	270	96

High-precision tapered roller bearings

For detailed specifications contact the nearest SKF application engineering service

Bearing bore diameter, mm	Designation							
	BT2B 328971 A/Q	BT2-0195	BT2-0067	BT2-0075	BT1-0112	BT2-0061	BT2-0032 A	BT2-0033 A
15								
17								
20								
25								
30								
35								
40	■							
45								
50								
55		■	■					
60								
65								
70								
75								
80				■				
85								
90								
95								
100								
105								
110								
120					■			
130								
140								
150								
155						■		
160								
170								
180							■	■

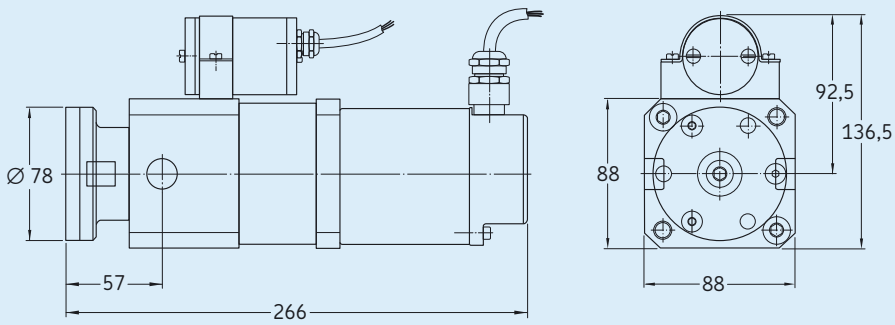
Designation	Principal dimensions				
	d	D	T	C	2B
–	mm				
BT2B 328971 A/Q	40	68	93	84	93
BT2-0195	55	100	60	43,5	60
BT2-0067	55	140	50	50	50
BT2-0075	80	175	61	57	59
BT1-0112	120	180	38	29	–
BT2-0061	155	200	66	54	66
BT2-0033 A	180	250	105	83	105
BT2-0032 A	180	250	205	183	205





Scandrive register unit

Scandrive register units



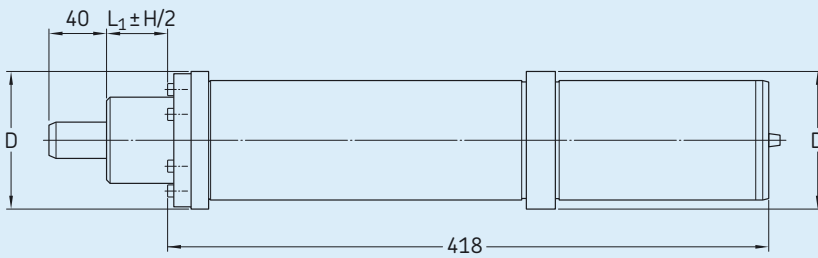
Designation	Max thrust force	Thrust bearing capacity		Mechanical stroke	Speed	Feedback	EMC shield
		C	C ₀				
–	kN	kN		mm	mm/s	–	–
AL30P	27	25	65	6	0–0,15	Potentiometer	Yes
AL20P	20	25	65	6	0–0,15	Potentiometer	Yes
AL05P	5	25	65	17	0–0,5	Potentiometer	Yes
AL05IND	5	25	65	12	0–0,5	Inductive	Optional
RGA	20	80	199	8	0–13	Dual potentiometer	No

For detailed specifications contact the nearest SKF application engineering service



Scandrive R84 internal oscillator

Scandrive R84 internal oscillators



Designation	Axial oscill. stroke H	Outer diameter D	Length L_1	Speed range	Axial oscill. at 1 000 r/min
–	mm	mm	mm	r/min	Hz
Ratio 34,00:1	7/11/16/25	84/91/96/101/110/114	17/41,5	0–2 500	0,5
Ratio 16,50:1	7/11/16/25	84/91/96/101/110/114	17/41,5	0–2 500	1,0
Ratio 10,67:1	7/11/16/25	84/91/96/101/110/114	17/41,5	0–2 500	1,6

For detailed specifications contact the nearest SKF application engineering service



Flameproof immersion pumps PAB and PNB

PAB and PNB sealless pumps can deliver paints containing solvents, varnishes as well as water-based. The PAB pump is characterized by a simple separation of motor and pump part, thus, improves efficiency in the printing process.

Features

- Sealless
- Single- and dual grade
- Open impellers
- ATEX approved
- Protection class EExe – “increased safety” or EExd – “flame-proof enclosure”
- Also for viscosities > 20 mm²/s
- Connection dimensions according to DIN 12157

Advantages

- High-strength and good chemical resistance
- Minimum weight
- High operational safety, low maintenance requirements
- PAB: Fast paint change by separating the motor from the pump

Performance

Delivery rate: Q_{\max} : 830 l/min

Delivery head: H_{\max} : 20 m

Catalogue

Additional information can be found in the Vogel publication: 1-6036 “Flameproof immersion pumps PAB and PNB”.



Oil circulation system

Pumps

Gerotor pumps are distinguished by quiet running and little pulsation. They have an internally geared delivery element (trochoid gearing). These pumps are well suited for the oil circulation systems on all types of printing presses and converting machines.

Volume: 0,85 l/min – 19 l/min (at 1 400 r/min)
Maximum back pressure: 20–50 bar

Additionally, SKF Lubrication Solutions offer gear pumps, cam pumps and complete pump units.

Catalogues

Additional information can be found in the Vogel publications: 1-1200 “Gear, gerotor and cam pumps” and 1-1204 “Single- and multicircuit pumps”.



Metering and monitoring

Flow metering and monitoring is key to a well performing oil circulation station. Flow sensors monitor oil flow. Flow limiters do both, meter and monitor, a constant oil flow independent of oil viscosity and back pressure.

Volume: 0,09–8,18 l/min

Maximum back pressure: 5–200 bar

Catalogues

Additional information can be found in the Vogel publication:

1-1704 “Flow monitors and sensors” and Dsk 0-050-08 “Flow limiter SP/SMB8”.

Valves, filters, and fittings are described in the catalogue Vogel publication: 1-0103 “Accessories and fittings”.

SKF Lubrication Solutions has a renowned engineering department that designs customer specific oil circulation systems.



Single line systems

Pump units

SKF Lubrication Solutions has a complete product portfolio for oil and fluid grease applications. The pump range includes compact units as well as gear units with large reservoirs. The units have modular specifications; it is up to the customer to choose for example manometer, level switch, or pressure switch.

Volume: 0,1–0,5 l/min

Medium: Oil or fluid grease up to NLGI 00

Catalogues

Additional information can be found in the Vogel publications:

1-1203 "Compact units for oil"

1-0016 "Compact units for fluid grease"

1-1202 "Gear pump units".



Piston distributors

Piston distributors meter out and distribute the oil delivered by an intermittently actuated pump. The quantities of oil for the individual lubrication points are determined by exchangeable metering nozzles. The amount needed to cover the total oil demand can then be further regulated via the lubricating frequency.

SKF Lubrication Solutions offers several lines of piston distributors to meet all individual demands for volumes and flexibility, for oil and fluid grease applications.

Rated metered quantity: 0,01–1,5 cm³

Piston distributors are also available with quick connectors. These enable customers to reduce maintenance time and simplify logistics.

Catalogues

Additional information can be found in the Vogel publications:

1-5001 "Piston distributors, metering units"

1-5015 "Metering units and piston distributors with quick connector system".



Pressure switches

The pressure switch is a key element in single-line centralized lubrication systems. Pressure switches monitor the pressure in the system to regulate the pump units.

SKF Lubrication Solutions has a full product line of pressure switches that ranges from 0,2 to 100 bar system pressure.

Catalogue

Additional information can be found in the Vogel publication:

1-1701-US "Pressure switches".



Progressive systems

Pumps

KFA and KFG piston pumps have been developed by SKF Lubrication Solutions for grease applications. They are supplied with 1 to 3 pump elements. Reservoir size ranges from 1 to 6 kg, maximum back pressure is 300 bar.

Pump: KFA1-M-W

1 kg reservoir, level switch, 24 V, delivery 1–2 cm³/min depending on pump element.

Pump: KFG1-5W1-M

2 kg reservoir, level switch, 24 V, delivery 0,8–6 cm³/min depending on pump element.

Catalogue

Additional information can be found in the Vogel publication:
1-0107-2-US "Piston pumps".



Progressive feeders

The progressive feeder feeds pressurized lubricant to the connected lubrication points one after another in specified fractional amounts. The lubricant is dispensed as long as it is fed to the progressive feeder under pressure.

The SKF Lubrication Solutions product portfolio comprises 6 different types of progressive feeders. The feeders differentiate in volume, alternative outlet ports, sectional or block design, or built-in check valves. The dispensed volume per cycle and outlet ranges from 0,05 up to 3,2 cm³.

Catalogue

Additional information can be found in the Vogel publication:
1-0107-1-US "Progressive feeders".



Single line grease systems

Single line grease systems are modular, high-performance grease lubrication systems that are well adapted to printing applications. Modularity and low stress on grease are key characteristics that help solve oil/soap separation of NLGI 2 greases. The system fits in sheet fed and web presses as well as post-press equipment.

Pump: KFG1-5W1-S3+924

24 V, level switch, 3/2 electrical relieve valve, 2 kg reservoir, delivery 60 cm³/15 min.

Piston distributors: 3601/3602 distributors are available in different metering volumes and outlet port fittings. Distributors are available with 2, 4, or 6 outlets. Any combination of metering volumes in one distributor is possible.

Catalogue

Additional information can be found in the Vogel publication:
1-0017-US "Single line system for grease NLGI 2".



Compact greaser

The Compact greaser with up to 5 outlet ports is an innovative solution suited for small lubrication systems. This easy and low-cost system requires minimal maintenance and is suitable for grease up to NLGI 2. The Compact greaser delivers metered volume from 10 to 20 mm³ per cycle. These units are typically used to lubricate the main bearings in printing presses, small gear drives in folder units and the bearings in drive motors.

Catalogue

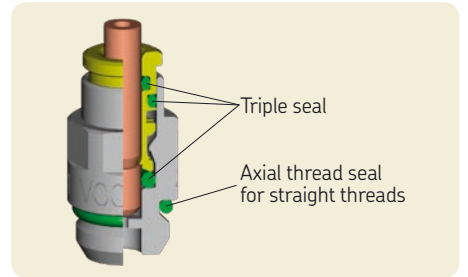
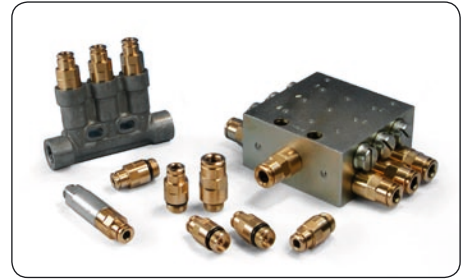
Additional information can be found in the Vogel publications:
1-0988-US "Compact Greaser".



Chain lubrication

SKF Lubrication solutions recommends a dedicated KFB pump for applications lubricated with high viscosity oils. These oils, which prevent printed sheets for becoming dirty, are typically used for lubricating the chains on sheet fed presses and die cutting machines. VPB or VPK progressive feeders can distribute the oil to various lubrication points.

Pump: KFB1-M-W-S1+924
24 V, level switch, 1 kg reservoir
maximum back pressure 38 bar.



Quick connect couplings

The novel seal and locking concept, which meets the "zero leakage" requirement of industrial users, is insensitive to dirt, easy to install and can be disconnected with the touch of a finger. These easy to use connectors can reduce installation and maintenance time, making them very suitable for use in printing presses.

Quick connectors are available in various sizes for piston distributors and progressive feeders.

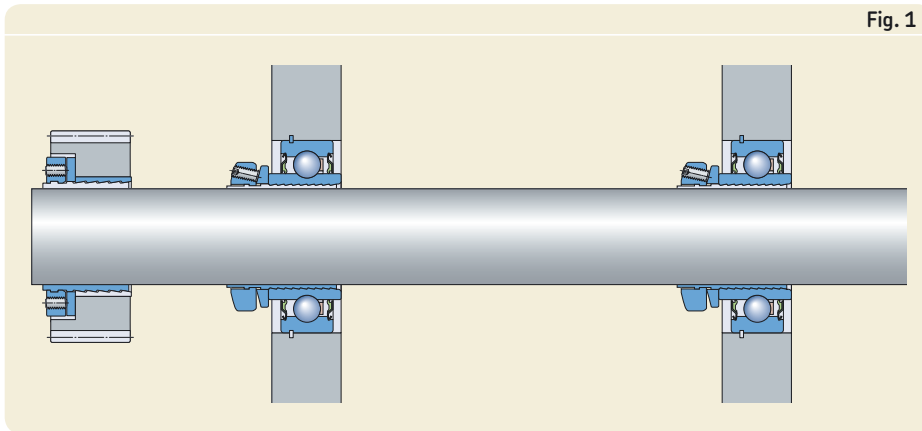
Catalogue

Additional information can be found in the Vogel publication:
1-0103-1-US "Connection system".

Application examples

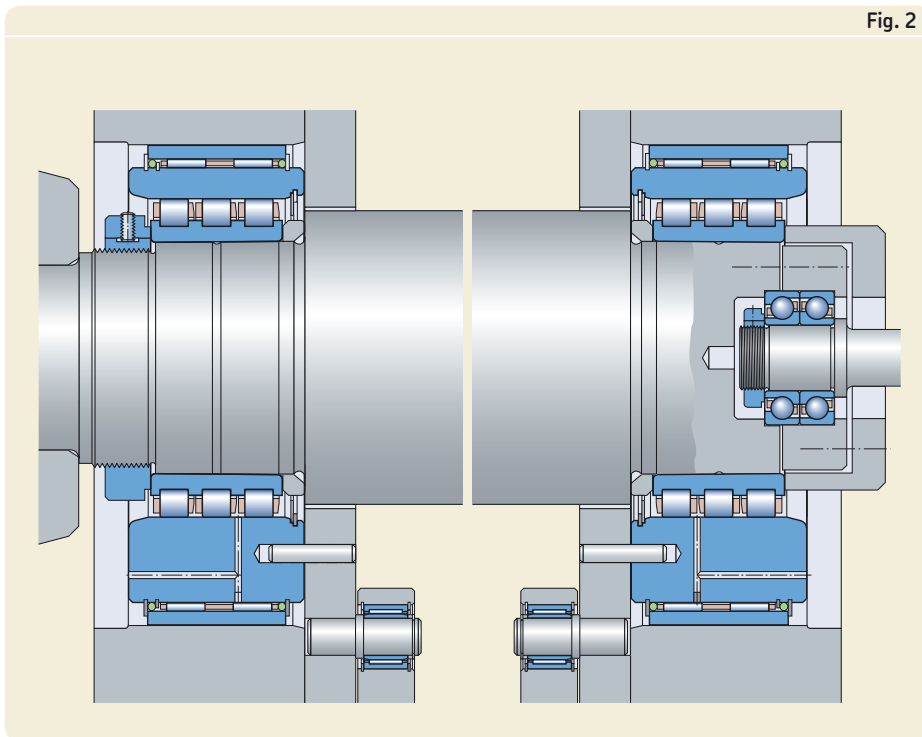


Fig. 1



*Guiding rollers, book binding and print finishing,
paper converting, packaging*
SKF ConCentra example

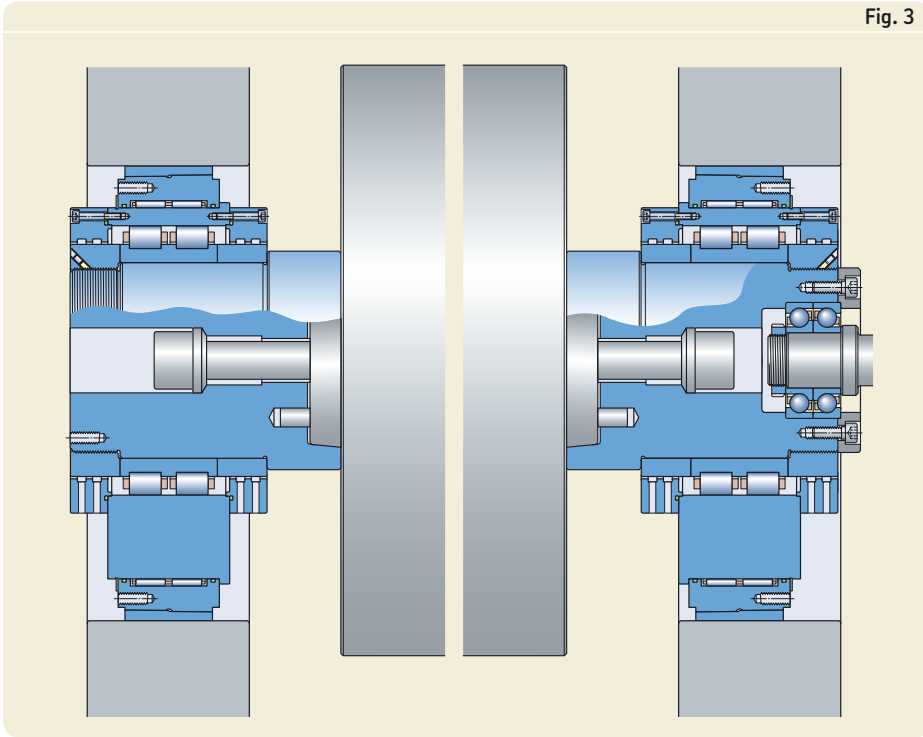
Fig. 2



Printing cylinder – non-locating solution
Typical printing cylinder arrangement “non-locating solution” with printing cylinder bearing units (PCU), high-precision lock nuts, matched single row angular contact ball bearings and needle roller bearings.

Very often used in web offset machines, both for newspapers and commercial printing, but also used in sheet fed offset machines and sometimes in flexographic machines for newspapers.

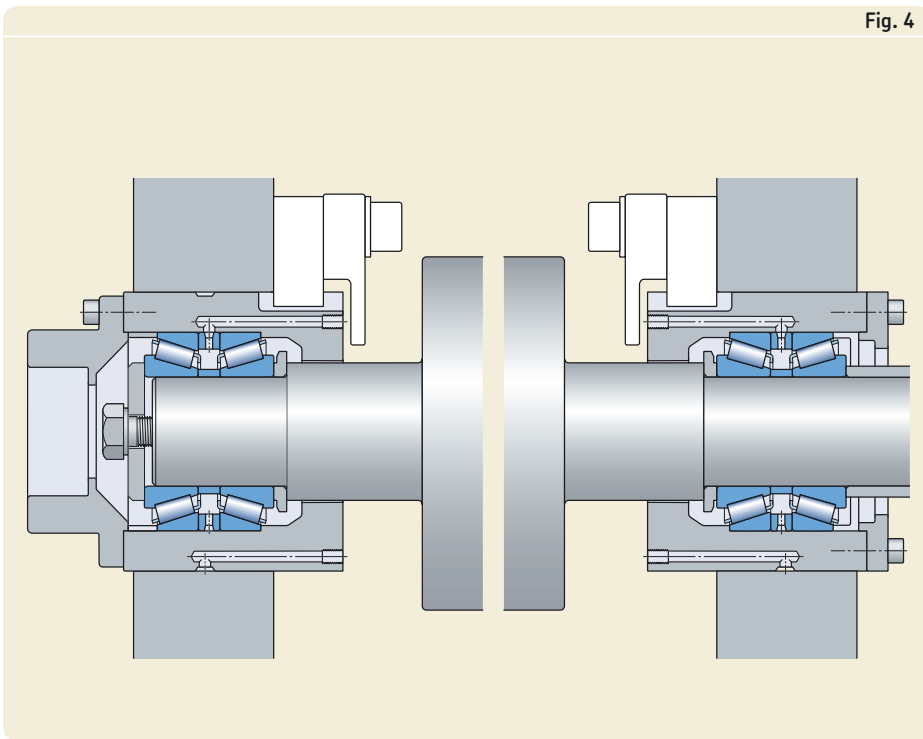
Fig. 3



Printing cylinder – non-locating solution

Typical printing cylinder arrangement “non-locating solution” with printing cylinder system (PCS, features → [page 12](#)), high-precision lock nuts and matched single row angular contact ball bearings

Fig. 4



Printing cylinder – locating solution

Typical printing cylinder arrangement “locating solution” with matched tapered roller bearing sets used in web and sheet fed offset machines

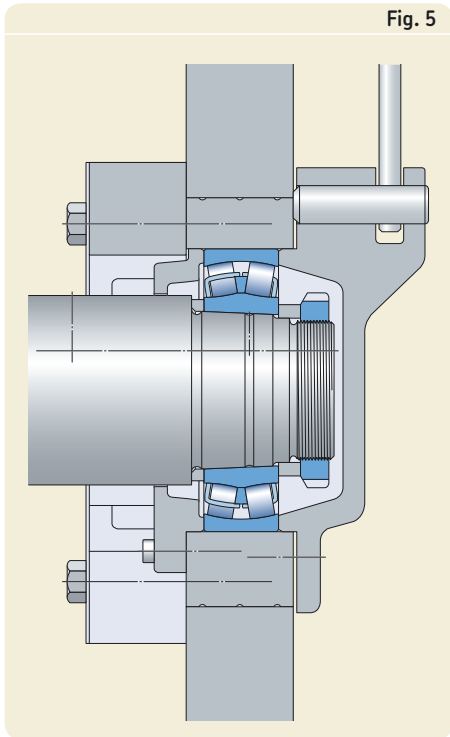


Fig. 5

Printing cylinder – locating solution

Typical printing cylinder arrangement “locating solution” with high-precision and preloaded spherical roller bearings used in web and sheet fed offset presses as well as flexographic and rotogravure presses

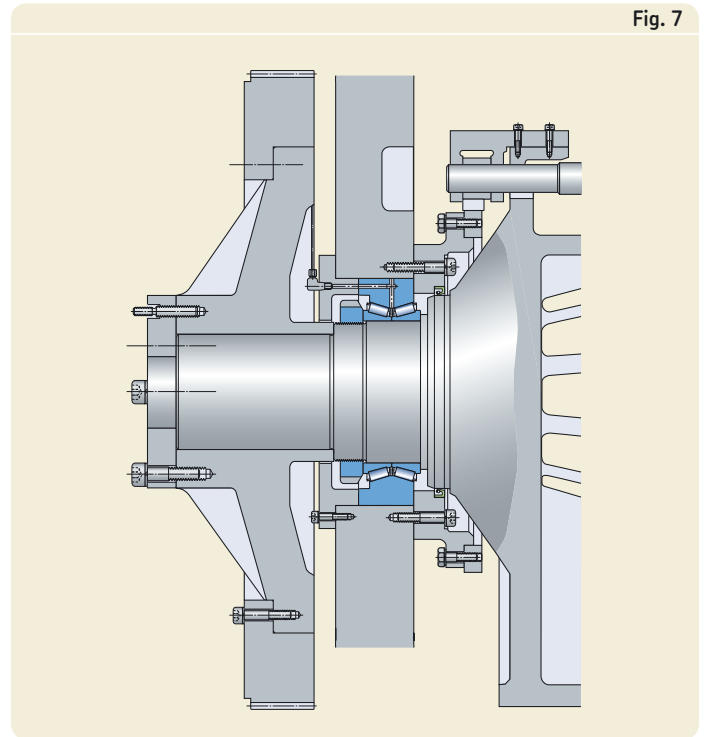


Fig. 7

Transfer cylinder – locating solution

Special tapered roller bearing in the locating position of a transfer cylinder in a sheet fed press

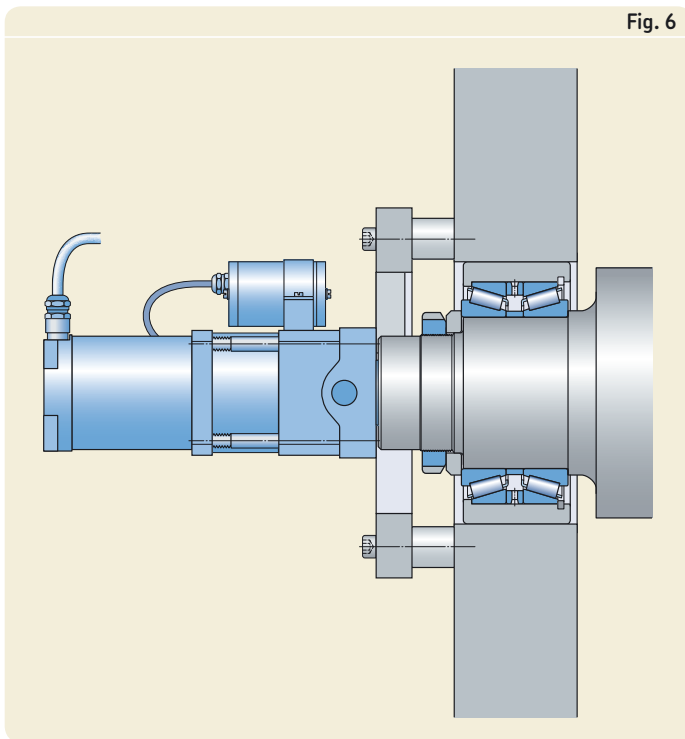


Fig. 6

Printing cylinder Scandrive sidelay register solution

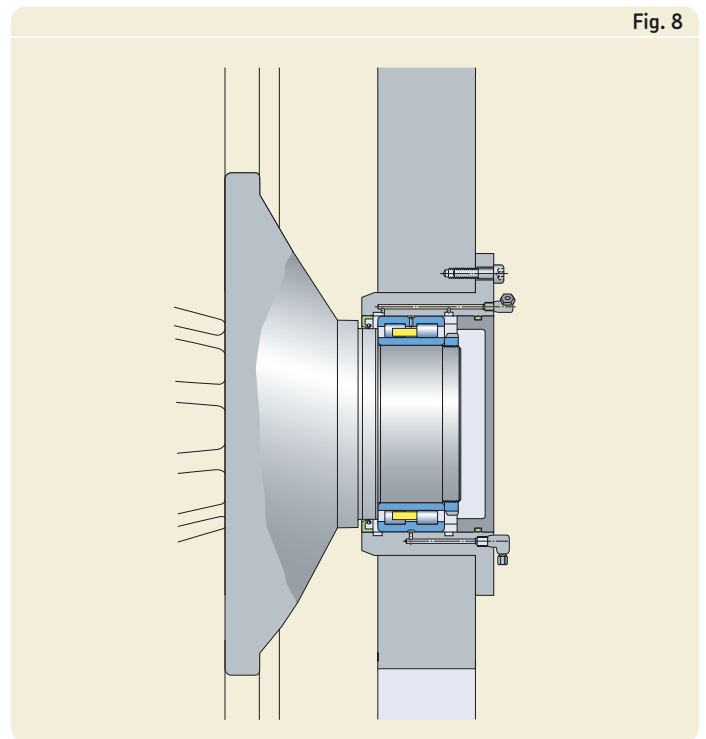
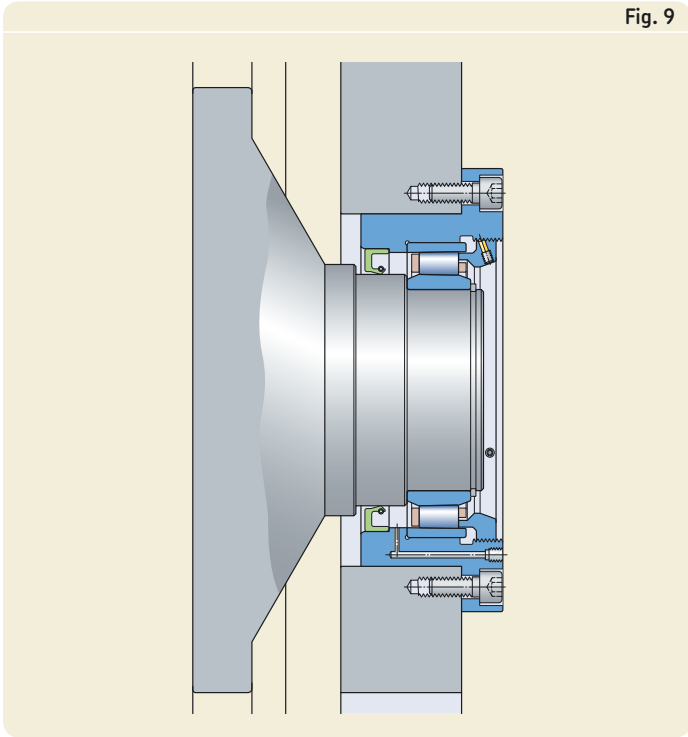


Fig. 8

Transfer cylinder – non-locating solution

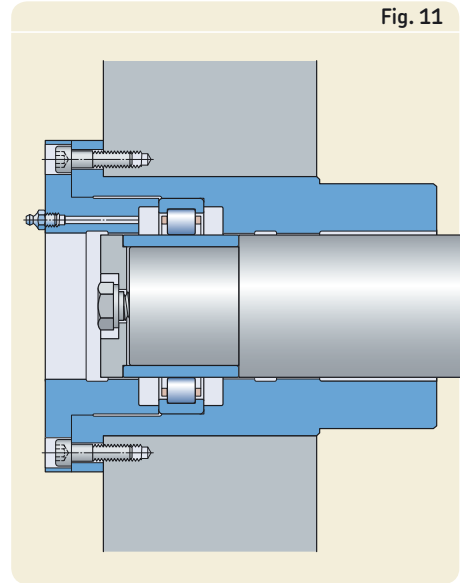
High-precision cylindrical roller bearing in the non-locating position of a transfer cylinder in a sheet fed press

Fig. 9



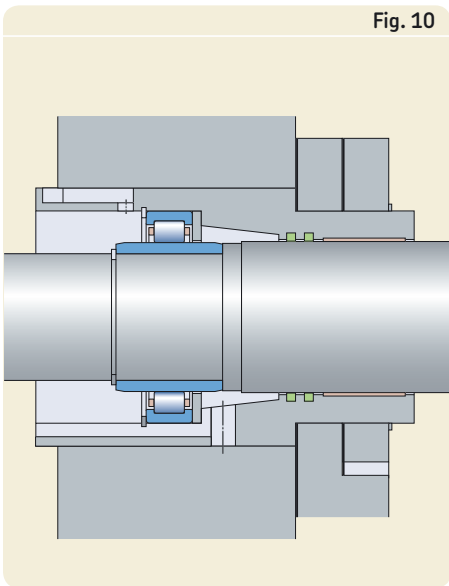
Transfer cylinder – non-locating solution
 PANLOC in the non-locating position of a transfer cylinder in a sheet fed press

Fig. 11



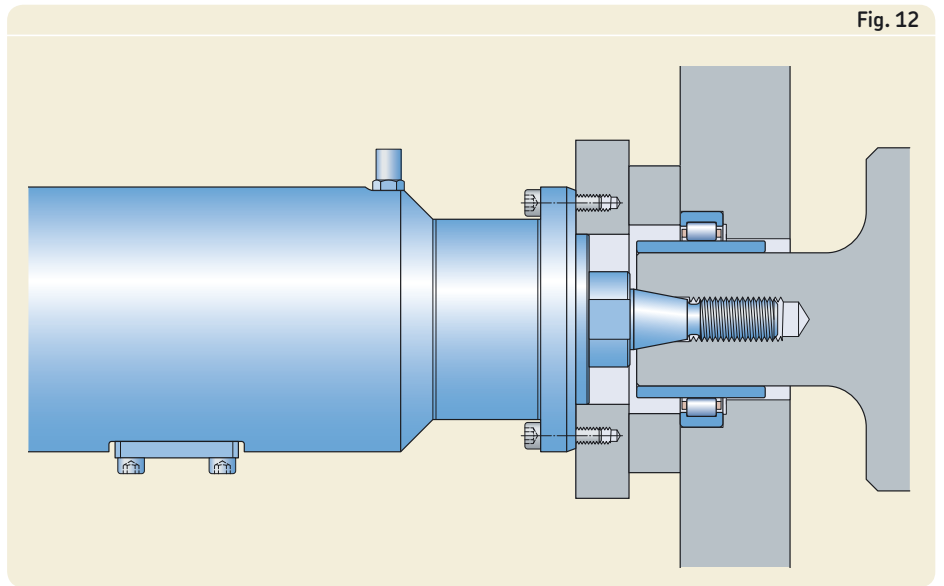
Oscillating inking roller
 Oscillating roller of an inking system fitted with an oscillating bearing unit (OBU)

Fig. 10



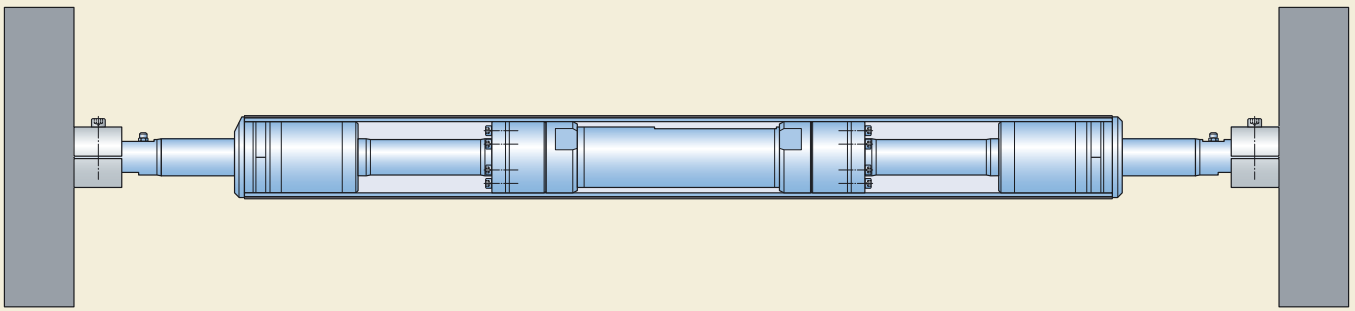
Oscillating inking roller
 Oscillating roller of an inking system using a cylindrical roller bearing with an extended inner ring

Fig. 12



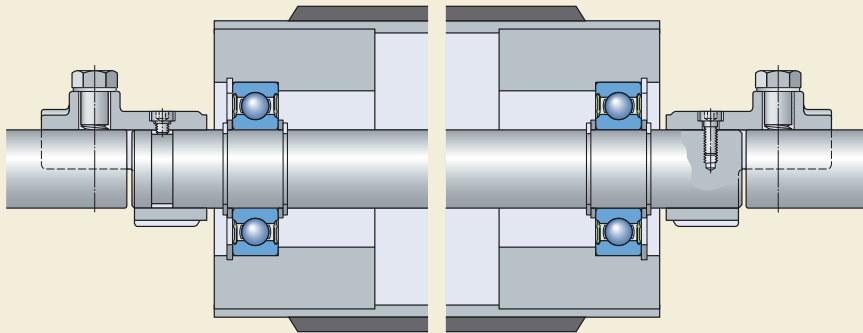
Oscillating inking roller
 Oscillating roller of an inking system equipped with a Scandrive external oscillator

Fig. 13



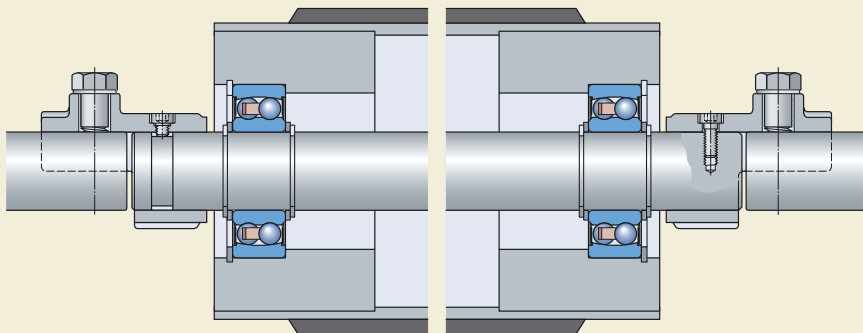
Oscillating inking roller
Application example of a Scandrive self-oscillating roller

Fig. 14



Web guiding roller
Bearing arrangement of a web guiding roller using sealed deep groove ball bearings

Fig. 15



Web guiding roller
Bearing arrangement of a web guiding roller using sealed self-aligning ball bearings

Printing problems and their solutions

Register problem

Even in this day and age of computer-to-plate technology, problems with registration can still occur.

The solution

The SKF register solutions provide these functionalities (circumferential, side lay and cocking register) to meet your customer print quality requirements (→ **fig. 1**). For more information on register units → **page 20**.

Register problem

Colour dots are not in position



Fig. 1

Scandrive
single register unit

Stripes and ghosting problems

Problems with colour balance and ink density leads to stripes and ghosting, but also vibration. This vibration occurs both at printing cylinders and inking/dampening rollers.

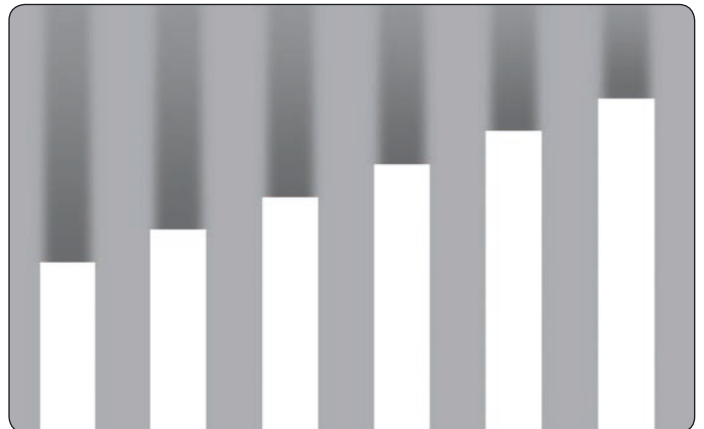
Stripes

Stripes caused by vibration, colour balance or ink density



Ghosting problems

Ghosting is often seen in offset presses and is difficult to eliminate





Vibration

Vibration is directly visible on the print. Vibration emerges from gap related impact of printing cylinders but also due to the complex machine design. Stiff and clearance free bearing arrangements at all machine conditions are extensively influencing the vibration behaviour of the complete machine structure.

The solution

SKF offers high performance bearing solutions specifically designed for the printing industry to safeguard clearance free and stiff conditions combined with high-precision (→ figs. 2 and 3).

For more information on PCU and PCS → page 12, for SKF PANLOC → page 11.

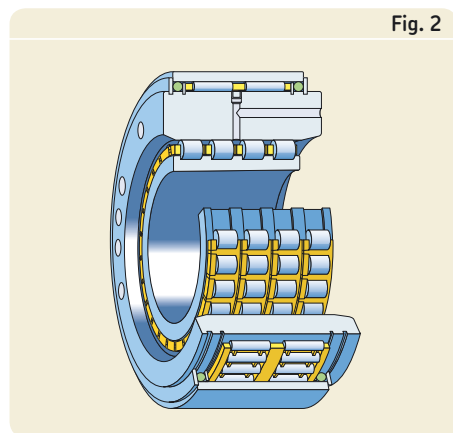


Fig. 2

Printing cylinder bearing unit (PCU)

SKF PANLOC

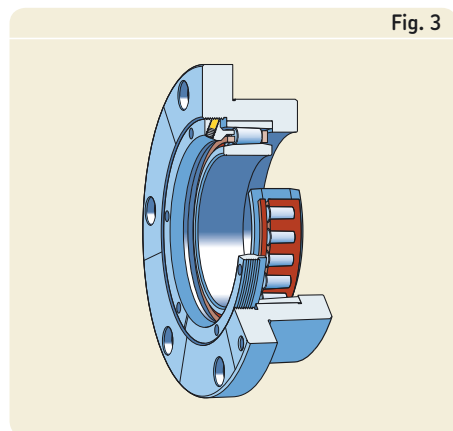


Fig. 3

Colour balance

Stripes, cloudy colour density and ghosting on a printed piece can be caused by an improper balance of ink, water and alcohol.

The oscillating function inside inking and dampening systems are key for this colour balance.

The solution

SKF offers excellent solutions for oscillating functions in inking and dampening systems, both for friction or gear driven mechanisms (→ figs. 4 and 5).

For more information on oscillators → pages 20 and 21.



Fig. 4

Scandrive external oscillator

Scandrive self-oscillating roller (single or double circumference)



Fig. 5

Ink density

The balance of ink and water should be constant over all printing speeds. Ink quantity instead must be adjusted to the printing speed. Ink keys are perfect to adjust the ink demand along the printing width whereas the SKF ductor drive unit safeguards the ink quantity related to all print speeds.

The solution

The SKF ductor drive unit adjusts the ductor speed corresponding to the press speed (→ fig. 6).

For more information on the SKF ductor drive unit → page 21.

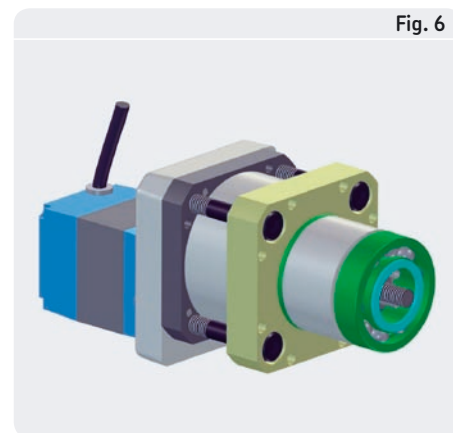


Fig. 6

Scandrive ductor drive unit

SKF – the knowledge engineering company

From the company that invented the self-aligning ball bearing more than 100 years ago, SKF has evolved into a knowledge engineering company that is able to draw on five technology platforms to create unique solutions for its customers. These platforms include bearings, bearing units and seals, of course, but extend to other areas including: lubricants and lubrication systems, critical for long bearing life in many applications; mechatronics that combine mechanical and electronics knowledge into systems for more effective linear motion and sensorized solutions; and a full range of services, from design and logistics support to conditioning monitoring and reliability systems.

Though the scope has broadened, SKF continues to maintain the world's leadership in the design, manufacture and marketing of rolling bearings, as well as complementary products such as radial seals. SKF also holds an increasingly important position in the market for linear motion products, high-precision aerospace bearings, machine tool spindles and plant maintenance services.

The SKF Group is globally certified to ISO 14001:2004, the international standard for environmental management, as well as OHSAS 18001, the health and safety management standard. Individual divisions have been approved for quality certification in accordance with either ISO 9001:2000 or ISO/TS 16949:2002.

With some 100 manufacturing sites worldwide and sales companies in 70 countries, SKF is a truly international corporation. In addition, our distributors and dealers in some 15 000 locations around the world, an e-business marketplace and a global distribution system put SKF close to customers for the supply of both products and services. In essence, SKF solutions are available wherever and whenever customers need them. Overall, the SKF brand and the corporation are stronger than ever. As the knowledge engineering company, we stand ready to serve you with world-class product competencies, intellectual resources, and the vision to help you succeed.

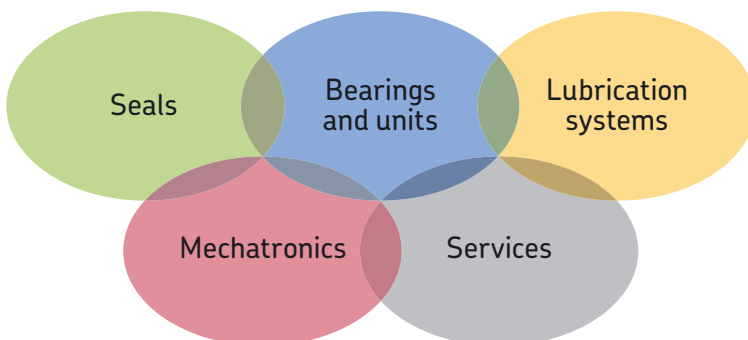


© Airbus – photo: e'm company, H. Goussé

Evolving by-wire technology

SKF has a unique expertise in fast-growing by-wire technology, from fly-by-wire, to drive-by-wire, to work-by-wire. SKF pioneered practical fly-by-wire technology and is a close working partner with all aerospace industry leaders. As an example, virtually all aircraft of the Airbus design use SKF by-wire systems for cockpit flight control.

SKF is also a leader in automotive by-wire technology, and has partnered with automotive engineers to develop two concept cars, which employ SKF mechatronics for steering and braking. Further by-wire development has led SKF to produce an all-electric forklift truck, which uses mechatronics rather than hydraulics for all controls.





Harnessing wind power

The growing industry of wind-generated electric power provides a source of clean, green electricity. SKF is working closely with global industry leaders to develop efficient and trouble-free turbines, providing a wide range of large, highly specialized bearings and condition monitoring systems to extend equipment life of wind farms located in even the most remote and inhospitable environments.



Working in extreme environments

In frigid winters, especially in northern countries, extreme sub-zero temperatures can cause bearings in railway axleboxes to seize due to lubrication starvation. SKF created a new family of synthetic lubricants formulated to retain their lubrication viscosity even at these extreme temperatures. SKF knowledge enables manufacturers and end user customers to overcome the performance issues resulting from extreme temperatures, whether hot or cold. For example, SKF products are at work in diverse environments such as baking ovens and instant freezing in food processing plants.



Developing a cleaner cleaner

The electric motor and its bearings are the heart of many household appliances. SKF works closely with appliance manufacturers to improve their products' performance, cut costs, reduce weight, and reduce energy consumption. A recent example of this cooperation is a new generation of vacuum cleaners with substantially more suction. SKF knowledge in the area of small bearing technology is also applied to manufacturers of power tools and office equipment.



Maintaining a 350 km/h R&D lab

In addition to SKF's renowned research and development facilities in Europe and the United States, Formula One car racing provides a unique environment for SKF to push the limits of bearing technology. For over 50 years, SKF products, engineering and knowledge have helped make Scuderia Ferrari a formidable force in F1 racing. (The average racing Ferrari utilizes more than 150 SKF components.) Lessons learned here are applied to the products we provide to auto-makers and the aftermarket worldwide.



Delivering Asset Efficiency Optimization

Through SKF Reliability Systems, SKF provides a comprehensive range of asset efficiency products and services, from condition monitoring hardware and software to maintenance strategies, engineering assistance and machine reliability programmes. To optimize efficiency and boost productivity, some industrial facilities opt for an Integrated Maintenance Solution, in which SKF delivers all services under one fixed-fee, performance-based contract.



Planning for sustainable growth

By their very nature, bearings make a positive contribution to the natural environment, enabling machinery to operate more efficiently, consume less power, and require less lubrication. By raising the performance bar for our own products, SKF is enabling a new generation of high-efficiency products and equipment. With an eye to the future and the world we will leave to our children, the SKF Group policy on environment, health and safety, as well as the manufacturing techniques, are planned and implemented to help protect and preserve the earth's limited natural resources. We remain committed to sustainable, environmentally responsible growth.



© SKF, PANLOC, SPEEDI-SLEEVE and VOGEL are registered trademarks of the SKF Group.

™ SKF Explorer and ICOS are trademarks of the SKF Group.

© SKF Group 2008

The contents of this publication are the copyright of the publisher and may not be reproduced (even extracts) unless permission is granted. Every care has been taken to ensure the accuracy of the information contained in this publication but no liability can be accepted for any loss or damage whether direct, indirect or consequential arising out of the use of the information contained herein.

Publication **6130 EN** · February 2008

This publication supersedes publication 4781 E.

Printed in Sweden on environmentally friendly paper.

www.skf.com