

CHAPTER 3

[Www.iepnu.ir](http://www.iepnu.ir)



PROBLEM 3.1

3.1 Determine the torque T which causes a maximum shearing stress of 70 MPa in the steel cylindrical shaft shown.

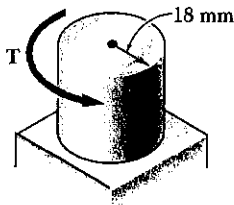

SOLUTION

$$\tau_{max} = \frac{Tc}{J} \quad J = \frac{\pi}{2}c^4$$

$$T = \frac{\pi}{2}c^3\tau_{max} = \frac{\pi}{2}(0.018)^3(70 \times 10^6) = 641 \text{ N}\cdot\text{m} \quad \blacktriangleleft$$

PROBLEM 3.2

3.2 Determine the maximum shearing stress caused by a torque of magnitude $T = 800 \text{ N}\cdot\text{m}$.

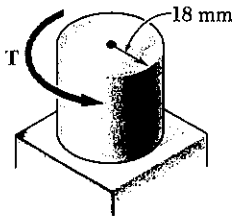

SOLUTION

$$\tau_{max} = \frac{Tc}{J} \quad J = \frac{\pi}{2}c^4$$

$$\tau_{max} = \frac{2T}{\pi c^3} = \frac{(2)(800)}{\pi(0.018)^3} = 87.3 \times 10^6 \text{ Pa}$$

$$87.3 \text{ MPa} \quad \blacktriangleleft$$

PROBLEM 3.3

3.3 Knowing that the internal diameter of the hollow shaft shown is $d = 0.9 \text{ in.}$, determine the maximum shearing stress caused by a torque of magnitude $T = 9 \text{ kip}\cdot\text{in.}$

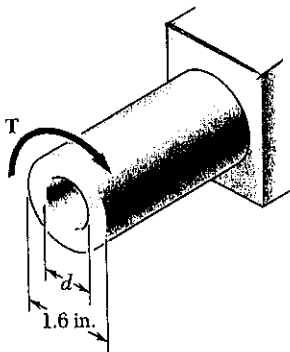

SOLUTION

$$c_2 = \frac{1}{2}d_2 = \left(\frac{1}{2}\right)(1.6) = 0.8 \text{ in.} \quad c = 0.8 \text{ in.}$$

$$c_1 = \frac{1}{2}d_1 = \left(\frac{1}{2}\right)(0.9) = 0.45 \text{ in.}$$

$$J = \frac{\pi}{2}(c_2^4 - c_1^4) = \frac{\pi}{2}(0.8^4 - 0.45^4) = 0.5790 \text{ in}^4$$

$$\tau_{max} = \frac{Tc}{J} = \frac{(9)(0.8)}{0.5790} = 12.44 \text{ ksi} \quad \blacktriangleleft$$

PROBLEM 3.4

3.4 Knowing that $d = 1.2 \text{ in.}$, determine the torque T which causes a maximum shearing stress of 7.5 ksi in the hollow shaft shown.

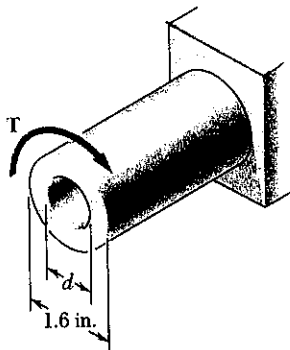

SOLUTION

$$c_2 = \frac{1}{2}d_2 = \left(\frac{1}{2}\right)(1.6) = 0.8 \text{ in.} \quad c = 0.8 \text{ in.}$$

$$c_1 = \frac{1}{2}d_1 = \left(\frac{1}{2}\right)(1.2) = 0.6 \text{ in.}$$

$$J = \frac{\pi}{2}(c_2^4 - c_1^4) = \frac{\pi}{2}(0.8^4 - 0.6^4) = 0.4398 \text{ in}^4$$

$$\tau_{max} = \frac{Tc}{J}$$

$$T = \frac{J\tau_{max}}{c} = \frac{(0.4398)(7.5)}{0.8} = 4.12 \text{ kip}\cdot\text{in.} \quad \blacktriangleleft$$

PROBLEM 3.5

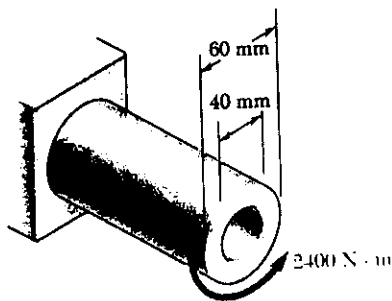

3.5 (a) For the hollow shaft and loading shown, determine the maximum shearing stress. (b) Determine the diameter of a solid shaft for which the maximum shearing stress is the same as in part a.

SOLUTION

$$c_1 = \frac{1}{2}d_1 = \left(\frac{1}{2}\right)(0.040) = 0.020 \text{ m}$$

$$c_2 = \frac{1}{2}d_2 = \left(\frac{1}{2}\right)(0.060) = 0.030 \text{ m} \quad c = 0.030 \text{ m}$$

$$J = \frac{\pi}{2}(c_2^4 - c_1^4) = \frac{\pi}{2}(0.030^4 - 0.020^4) \\ = 1.0210 \times 10^{-6} \text{ m}^4$$

$$(a) \tau_{\max} = \frac{Tc}{J} = \frac{(2400)(0.03)}{1.0210 \times 10^{-6}} = 70.52 \times 10^6 \text{ Pa}$$

$$70.5 \text{ MPa} \quad \blacktriangleleft$$

$$(b) \tau = \frac{Tc_3}{J}, \quad J = \frac{\pi}{2}c_3^4, \quad \tau = \frac{2T}{\pi c_3^3}$$

$$c_3^3 = \frac{2T}{\pi\tau} = \frac{(2)(2400)}{\pi(70.52 \times 10^6)} = 21.67 \times 10^{-6} \text{ m}^3$$

$$c_3 = 27.88 \times 10^{-3} \text{ m} \quad d_3 = 2c_3 = 55.8 \times 10^{-3} \text{ m}$$

$$55.8 \text{ mm} \quad \blacktriangleleft$$

PROBLEM 3.6

3.6 (a) Determine the torque which may be applied to a solid shaft of 90-mm outer diameter without exceeding an allowable shearing stress of 75 MPa. (b) Solve part a, assuming that the solid shaft is replaced by a hollow shaft of the same mass and of 90-mm inner diameter.

SOLUTION

$$(a) \text{ For the solid shaft } c = \frac{1}{2}d = \left(\frac{1}{2}\right)(0.090) = 0.045 \text{ m}$$

$$\frac{J}{c} = \frac{\pi}{2}c^3 = \frac{\pi}{2}(0.045)^3 = 143.14 \times 10^{-6} \text{ m}^3$$

$$\tau_{\max} = \frac{Tc}{J} \therefore T = \frac{\tau_{\max}J}{c} = \frac{(75 \times 10^6)(143.14 \times 10^{-6})}{0.045} = 10.74 \times 10^3 \text{ N}\cdot\text{m}$$

$$10.74 \text{ kN}\cdot\text{m} \quad \blacktriangleleft$$

$$(b) \text{ Hollow shaft } c_1 = \frac{1}{2}d_i = \left(\frac{1}{2}\right)(0.090) = 0.045 \text{ m}$$

For equal masses the cross sectional areas must be equal

$$A = \pi c^2 = \pi(c_2^2 - c_1^2) \quad \text{or} \quad c_2 = \sqrt{c_1^2 + c^2}$$

$$c_2 = \sqrt{0.045^2 + 0.045^2} = 0.0636396 \text{ m}$$

$$J = \frac{\pi}{2}(c_2^4 - c_1^4) = 19.3237 \times 10^{-6} \text{ m}^4$$

$$T = \frac{\tau_{\max}J}{c_2} = \frac{(75 \times 10^6)(19.3237 \times 10^{-6})}{0.0636396} = 22.77 \times 10^3 \text{ N}\cdot\text{m}$$

$$22.8 \text{ kN}\cdot\text{m} \quad \blacktriangleleft$$

PROBLEM 3.7

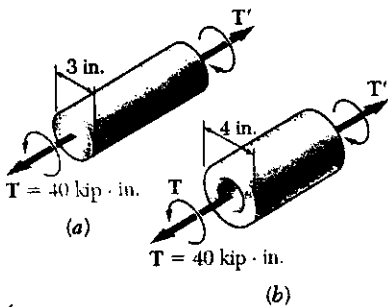

3.7 (a) For the 3-in.-diameter solid cylinder and loading shown, determine the maximum shearing stress. (b) Determine the inner diameter of the hollow cylinder, of 4-in. outer diameter, for which the maximum stress is the same as in part a.

SOLUTION

(a) Solid shaft $c = \frac{1}{2}d = \frac{1}{2}(3.0) = 1.5 \text{ in.}$

$$\tau_{\max} = \frac{Tc}{J} = \frac{2T}{\pi c^3} = \frac{(2)(40)}{\pi(1.5)^3} = 7.545 \text{ ksi} \quad \blacktriangleleft$$

(b) Hollow shaft $c_2 = \frac{1}{2}d = \frac{1}{2}(4.0) = 2.0 \text{ in.}$

$$\frac{J}{c_2} = \frac{\frac{\pi}{2}(c_2^4 - c_1^4)}{c_2} = \frac{T}{\tau_{\max}}$$

$$c_1^4 = c_2^4 - \frac{2Tc_2}{\pi \tau_{\max}} = 2.0^4 - \frac{(2)(40)(2.0)}{\pi(7.545)} = 9.25 \text{ in}^4$$

$$c_1 = 1.74395 \text{ in} \quad d_1 = 2c_1 = 3.49 \text{ in} \quad \blacktriangleleft$$

PROBLEM 3.8

3.8 (a) Determine the torque which may be applied to a solid shaft of 0.75-in. diameter without exceeding an allowable shearing stress of 10 ksi. (b) Solve part a, assuming that the solid shaft has been replaced by a hollow shaft of the same cross-sectional area and with an inner diameter equal to half its outer diameter..

SOLUTION

(a) Solid shaft: $c = \frac{1}{2}d = (\frac{1}{2})(0.75) = 0.375 \text{ in.}$

$$J = \frac{\pi}{2}c^4 = \frac{\pi}{2}(0.375)^4 = 0.031063 \text{ in}^4 \quad \tau_{\max} = 10 \text{ ksi}$$

$$T = \frac{J\tau_{\max}}{c} = \frac{(0.031063)(10)}{0.375} = 0.828 \text{ kip}\cdot\text{in} \text{ or } 828 \text{ lb}\cdot\text{in} \quad \blacktriangleleft$$

(b) Hollow shaft

For the same area as the solid shaft

$$A = \pi(c_2^2 - c_1^2) = \pi\left[c_2^2 - \left(\frac{1}{2}c_2\right)^2\right] = \frac{3}{4}\pi c_2^2 = \pi c^2$$

$$c_2 = \frac{2}{\sqrt{3}}c = \frac{2}{\sqrt{3}}(0.375) = 0.433013 \text{ in}$$

$$c_1 = \frac{1}{2}c_2 = 0.216506$$

$$J = \frac{\pi}{2}(c_2^4 - c_1^4) = \frac{\pi}{2}(0.433013^4 - 0.216506^4) = 0.051772 \text{ in}^4$$

$$T = \frac{\tau_{\max}J}{c_2} = \frac{(10)(0.051772)}{0.433013} = 1.196 \text{ kip}\cdot\text{in} \text{ or } 1196 \text{ in}\cdot\text{lb.} \quad \blacktriangleleft$$

PROBLEM 3.9

3.9 The torques shown are exerted on pulleys *A* and *B*. Knowing that each shaft is solid, determine the maximum shearing stress (*a*) in shaft *AB*, (*b*) in shaft *BC*.

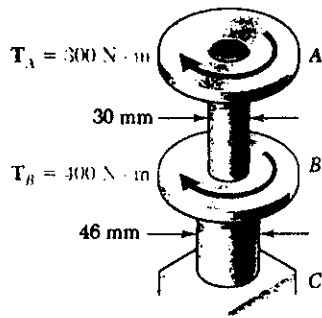

SOLUTION

Shaft *AB*: $T_{AB} = 300 \text{ N}\cdot\text{m}$, $d = 0.030 \text{ m}$, $c = 0.015 \text{ m}$

$$\tau_{\max} = \frac{Tc}{J} = \frac{2T}{\pi c^3} = \frac{(2)(300)}{\pi (0.015)^3}$$

$$= 56.588 \times 10^6 \text{ Pa} = 56.6 \text{ MPa} \quad \blacktriangleleft$$

Shaft *BC*: $T_{BC} = 300 + 400 = 700 \text{ N}\cdot\text{m}$

$d = 0.046 \text{ m}$, $c = 0.023 \text{ m}$

$$\tau_{\max} = \frac{Tc}{J} = \frac{2T}{\pi c^3} = \frac{(2)(700)}{\pi (0.023)^3}$$

$$= 36.626 \times 10^6 \text{ Pa} = 36.6 \text{ MPa} \quad \blacktriangleleft$$

PROBLEM 3.10

3.10 The torques shown are exerted on pulleys *A* and *B* which are attached to solid circular shafts *AB* and *BC*. In order to reduce the total mass of the assembly, determine the smallest diameter of shaft *BC* for which the largest shearing stress in the assembly is not increased.

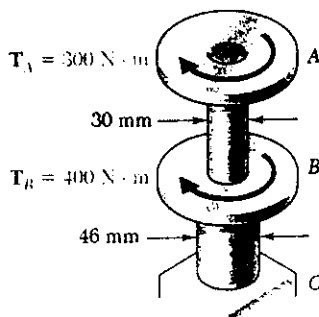

SOLUTION

Shaft *AB*: $T_{AB} = 300 \text{ N}\cdot\text{m}$, $d = 0.030 \text{ m}$, $c = 0.015 \text{ m}$

$$\tau_{\max} = \frac{Tc}{J} = \frac{2T}{\pi c^3} = \frac{(2)(300)}{\pi (0.015)^3}$$

$$= 56.588 \times 10^6 \text{ Pa} = 56.6 \text{ MPa}$$

Shaft *BC*: $T_{BC} = 300 + 400 = 700 \text{ N}\cdot\text{m}$

$d = 0.046 \text{ m}$, $c = 0.023 \text{ m}$

$$\tau_{\max} = \frac{Tc}{J} = \frac{2T}{\pi c^3} = \frac{(2)(700)}{\pi (0.023)^3}$$

$$= 36.626 \times 10^6 \text{ Pa} = 36.6 \text{ MPa}$$

The largest stress ($56.588 \times 10^6 \text{ Pa}$) occurs in portion AB

Reduce the diameter of *BC* to provide the same stress.

$$T_{BC} = 700 \text{ N}\cdot\text{m} \quad \tau_{\max} = \frac{Tc}{J} = \frac{2T}{\pi c^3}$$

$$c^3 = \frac{2T}{\pi \tau_{\max}} = \frac{(2)(700)}{\pi (56.588 \times 10^6)} = 7.875 \times 10^{-6} \text{ m}^3$$

$$c = 19.895 \times 10^{-3} \text{ m} \quad d = 2c = 39.79 \times 10^{-3} \text{ m} \quad 39.8 \text{ mm} \quad \blacktriangleleft$$

PROBLEM 3.11

3.11 Knowing that each portion of the shaft AD consists of a solid circular rod, determine (a) the portion of the shaft in which the maximum shearing stress occurs, (b) the magnitude of that stress.

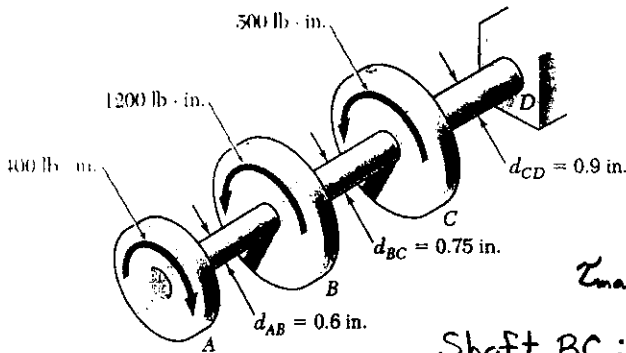

SOLUTION

Shaft AB: $T = 400 \text{ lb}\cdot\text{in}$

$c = \frac{1}{2}d = 0.30 \text{ in}$

$\tau_{\max} = \frac{Tc}{J} = \frac{2T}{\pi c^3}$

$\tau_{\max} = \frac{(2)(400)}{\pi (0.30)^3} = 9431 \text{ psi}$

Shaft BC: $T = -400 + 1200 = 800 \text{ lb}\cdot\text{in}$

$c = \frac{1}{2}d = 0.375 \text{ in}$ $\tau_{\max} = \frac{Tc}{J} = \frac{2T}{\pi c^3} = \frac{(2)(800)}{\pi (0.375)^3} = 9658 \text{ psi}$

Shaft CD: $T = -400 + 1200 + 500 = 1300 \text{ lb}\cdot\text{in}$

$c = \frac{1}{2}d = 0.45 \text{ in}$ $\tau_{\max} = \frac{Tc}{J} = \frac{2T}{\pi c^3} = \frac{(2)(1300)}{\pi (0.45)^3} = 9082 \text{ psi}$

Answers: (a) shaft BC (b) 9.66 ksi

PROBLEM 3.12

3.12 Knowing that a 0.30-in.-diameter hole has been drilled through each portion of shaft AD , determine (a) the portion of the shaft in which the maximum shearing stress occurs, (b) the magnitude of that stress.

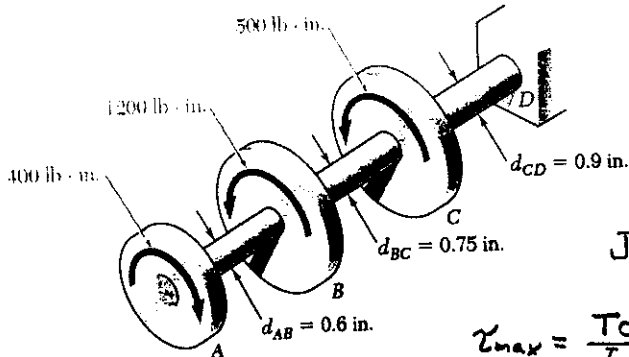

SOLUTION

Hole: $c_1 = \frac{1}{2}d_1 = 0.15 \text{ in}$

Shaft AB: $T = 400 \text{ lb}\cdot\text{in}$

$c_2 = \frac{1}{2}d_2 = 0.30 \text{ in}$

$J = \frac{\pi}{2}(c_2^4 - c_1^4) = \frac{\pi}{2}(0.30^4 - 0.15^4) = 0.011928 \text{ in}^4$

$\tau_{\max} = \frac{Tc_2}{J} = \frac{(400)(0.30)}{0.011928} = 10600 \text{ psi}$

Shaft BC: $T = -400 + 1200 = 800 \text{ lb}\cdot\text{in}$ $c_2 = \frac{1}{2}d_2 = 0.375 \text{ in}$

$J = \frac{\pi}{2}(c_2^4 - c_1^4) = \frac{\pi}{2}(0.375^4 - 0.15^4) = 0.030268 \text{ in}^4$

$\tau_{\max} = \frac{Tc_2}{J} = \frac{(800)(0.375)}{0.030268} = 9911 \text{ psi}$

Shaft CD: $T = -400 + 1200 + 500 = 1300 \text{ lb}\cdot\text{in}$ $c_2 = \frac{1}{2}d_2 = 0.45 \text{ in}$

$J = \frac{\pi}{2}(c_2^4 - c_1^4) = \frac{\pi}{2}(0.45^4 - 0.15^4) = 0.063617 \text{ in}^4$

$\tau_{\max} = \frac{Tc_2}{J} = \frac{(1300)(0.45)}{0.063617} = 9196 \text{ psi}$

Answers: (a) shaft AB (b) 10.06 ksi

PROBLEM 3.13

3.13 Under normal operating conditions, the electric motor exerts a torque of 2.4 kN·m at A. Knowing that each shaft is solid, determine the maximum shearing stress (a) in shaft AB, (b) in shaft BC, (c) in shaft CD.

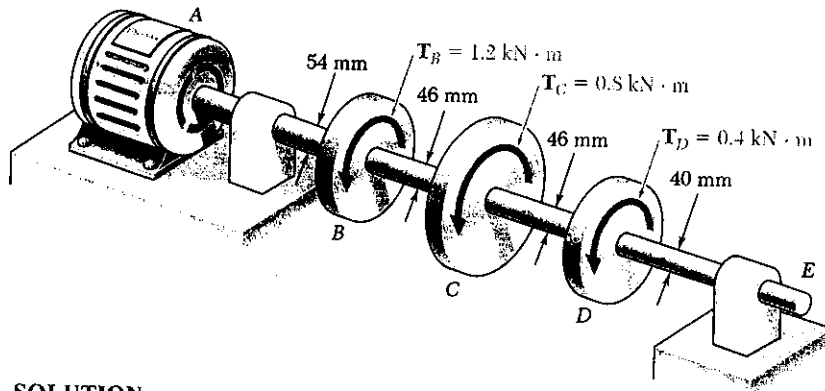

SOLUTION

Shaft AB: $T_{AB} = 2.4 \times 10^3 \text{ N}\cdot\text{m}$, $c = \frac{1}{2}d = 0.027 \text{ m}$

$$\tau_{AB} = \frac{Tc}{J} = \frac{2T}{\pi c^3} = \frac{(2)(2.4 \times 10^3)}{\pi (0.027)^3} = 77.625 \times 10^6 \text{ Pa} \quad 77.6 \text{ MPa} \blacktriangleleft$$

Shaft BC: $T_{BC} = 2.4 \text{ kN}\cdot\text{m} - 1.2 \text{ kN}\cdot\text{m} = 1.2 \text{ kN}\cdot\text{m}$, $c = \frac{1}{2}d = 0.023 \text{ m}$

$$\tau_{BC} = \frac{Tc}{J} = \frac{2T}{\pi c^3} = \frac{(2)(1.2 \times 10^3)}{\pi (0.023)^3} = 62.788 \times 10^6 \text{ Pa} \quad 62.8 \text{ MPa} \blacktriangleleft$$

Shaft CD: $T_{CD} = 0.4 \times 10^3 \text{ N}\cdot\text{m}$, $c = \frac{1}{2}d = 0.023 \text{ m}$

$$\tau_{CD} = \frac{Tc}{J} = \frac{2T}{\pi c^3} = \frac{(2)(0.4 \times 10^3)}{\pi (0.023)^3} = 20.929 \times 10^6 \text{ Pa} \quad 20.9 \text{ MPa} \blacktriangleleft$$

PROBLEM 3.14

3.14 Under normal operating conditions, the electric motor exerts a torque of 2.4 kN·m at A. In order to reduce the mass of the assembly, determine the smallest diameter of shaft BC for which the largest shearing stress in the assembly is not increased.

SOLUTION

See solution to problem 3.13 for figure and for maximum shearing stresses in portions AB, BC, and CD of the shaft. The largest value is $\tau_{max} = 77.625 \times 10^6 \text{ Pa}$ occurring in AB.

Adjust diameter of BC to obtain the same value of stress

$$\tau = \frac{Tc}{J} = \frac{2T}{\pi c^3}$$

$$c^3 = \frac{2T}{\pi \tau} = \frac{(2)(1.2 \times 10^3)}{\pi (77.625 \times 10^6)} = 9.8415 \times 10^{-6} \text{ m}^3$$

$$c = 21.43 \times 10^{-3} \text{ m} \quad d = 2c = 42.8 \times 10^{-3} \text{ m} \quad 42.8 \text{ mm} \blacktriangleleft$$

PROBLEM 3.15

3.15 The allowable stress is 15 ksi in the 1.5-in.-diameter rod *AB* and 8 ksi in the 1.8-in.-diameter rod *BC*. Neglecting the effect of stress concentrations, determine the largest torque that may be applied at *A*.

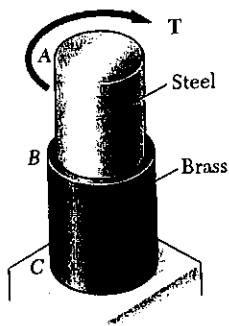

SOLUTION

$$\tau_{max} = \frac{Tc}{J}, \quad J = \frac{\pi}{2} c^4, \quad T = \frac{\pi}{2} c^3 \tau_{max}$$

Shaft *AB*: $\tau_{max} = 15 \text{ ksi}$ $c = \frac{1}{2}d = 0.75 \text{ in}$

$$T = \frac{\pi}{2} (0.75)^3 (15) = 9.94 \text{ kip}\cdot\text{in}$$

Shaft *BC*: $\tau_{max} = 8 \text{ ksi}$ $c = \frac{1}{2}d = 0.90 \text{ in}$

$$T = \frac{\pi}{2} (0.90)^3 (8) = 9.16 \text{ kip}\cdot\text{in}$$

The allowable torque is the smaller value

$$T = 9.16 \text{ kip}\cdot\text{in} \quad \blacktriangleleft$$

PROBLEM 3.16

3.16 The allowable stress is 15 ksi in the steel rod *AB* and 8 ksi in the brass rod *BC*. Knowing that a torque $T = 10 \text{ kip}\cdot\text{in}$. is applied at *A*, determine the required diameter of (a) rod *AB*, (b) for *BC*.

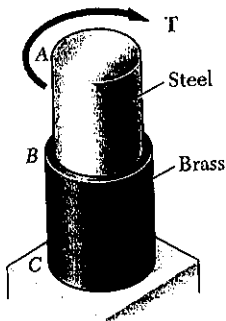

SOLUTION

$$\tau_{max} = \frac{Tc}{J}, \quad J = \frac{\pi}{2} c^4, \quad c^3 = \frac{2T}{\pi \tau_{max}}$$

Shaft *AB*: $T = 10 \text{ kip}\cdot\text{in}$ $\tau_{max} = 15 \text{ ksi}$

$$c^3 = \frac{(2)(10)}{\pi (15)} = 0.4244 \text{ in}^3$$

$$c = 0.7515 \text{ in} \quad d = 2c = 1.503 \text{ in} \quad \blacktriangleleft$$

Shaft *BC*: $T = 10 \text{ kip}\cdot\text{in}$ $\tau_{max} = 8 \text{ ksi}$

$$c^3 = \frac{(2)(10)}{\pi (8)} = 0.79577 \text{ in}^3$$

$$c = 0.9267 \text{ in} \quad d = 2c = 1.853 \text{ in} \quad \blacktriangleleft$$

PROBLEM 3.17

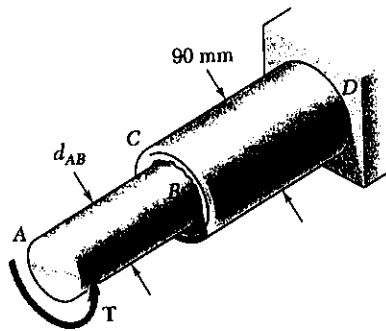

3.17 The solid rod AB has a diameter $d_{AB} = 60$ mm. The pipe CD has an outer diameter of 90 mm and a wall thickness of 6 mm. Knowing that both the rod and the pipe are made of a steel for which the allowable shearing stress is 75 MPa, determine the largest torque T which may be applied at A .

SOLUTION

$$\tau_{all} = 75 \times 10^6 \text{ Pa} \quad T_{all} = \frac{J \tau_{all}}{c}$$

$$\text{Rod } AB: c = \frac{1}{2}d = 0.030 \text{ m}, \quad J = \frac{\pi}{2}c^4$$

$$T_{all} = \frac{\pi}{2}c^3 \tau_{all} = \frac{\pi}{2}(0.030)^3(75 \times 10^6) \\ = 3.181 \times 10^3 \text{ N}\cdot\text{m}$$

$$\text{Pipe } CD: c_2 = \frac{1}{2}d_2 = 0.045 \text{ m} \quad c_1 = c_2 - t = 0.045 - 0.006 = 0.039 \text{ m}$$

$$J = \frac{\pi}{2}(c_2^4 - c_1^4) = \frac{\pi}{2}(0.045^4 - 0.039^4) = 2.8073 \times 10^{-6} \text{ m}^4$$

$$T_{all} = \frac{(2.8073 \times 10^{-6})(75 \times 10^6)}{0.045} = 4.679 \times 10^3 \text{ N}\cdot\text{m}$$

Allowable torque is the smaller value ($3.18 \times 10^3 \text{ N}\cdot\text{m}$) $3.18 \text{ kN}\cdot\text{m}$ ◀

PROBLEM 3.18

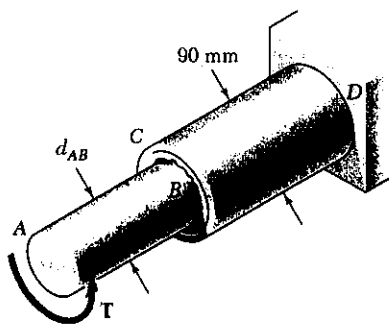

3.18 The solid rod AB has a diameter $d = 60$ mm and is made of a steel for which the allowable shearing stress is 85 MPa. The pipe CD has an outer diameter of 90 mm and a wall thickness of 6 mm; it is made of an aluminum for which the allowable shearing stress is 54 MPa. Determine the largest torque T which may be applied at A .

SOLUTION

$$\text{Rod } AB: \tau_{all} = 85 \times 10^6 \text{ Pa}, \quad c = \frac{1}{2}d = 0.030 \text{ m}$$

$$T_{all} = \frac{J \tau_{all}}{c} = \frac{\pi}{2}c^3 \tau_{all}$$

$$= \frac{\pi}{2}(0.030)^3(85 \times 10^6) = 3.605 \times 10^3 \text{ N}\cdot\text{m}$$

$$\text{Pipe } CD: \tau_{all} = 54 \times 10^6 \text{ Pa} \quad c_2 = \frac{1}{2}d_2 = 0.045 \text{ m}$$

$$c_1 = c_2 - t = 0.045 - 0.006 = 0.039 \text{ m}$$

$$J = \frac{\pi}{2}(c_2^4 - c_1^4) = \frac{\pi}{2}(0.045^4 - 0.039^4) = 2.8073 \times 10^{-6} \text{ m}^4$$

$$T_{all} = \frac{J \tau_{all}}{c_2} = \frac{(2.8073 \times 10^{-6})(54 \times 10^6)}{0.045} = 3.369 \times 10^3 \text{ N}\cdot\text{m}$$

Allowable torque is smaller value $T_{all} = 3.369 \times 10^3 \text{ N}\cdot\text{m}$

$3.37 \text{ kN}\cdot\text{m}$ ◀

PROBLEM 3.19

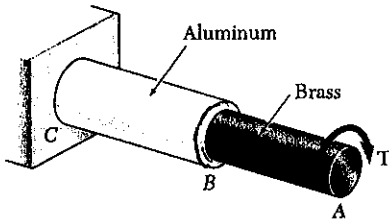

3.19 The allowable stress is 50 MPa in the brass rod *AB* and 25 MPa in the aluminum rod *BC*. Knowing that a torque $T = 1250 \text{ N}\cdot\text{m}$ is applied at *A*, determine the required diameter of (a) rod *AB*, (b) for *BC*.

SOLUTION

$$\tau_{\max} = \frac{Tc}{J} \quad J = \frac{\pi}{2} c^4 \quad c^3 = \frac{2T}{\pi \tau_{\max}}$$

$$\text{Rod AB: } c^3 = \frac{(2)(1250)}{\pi(50 \times 10^6)} = 15.915 \times 10^{-6} \text{ m}^3$$

$$c = 25.15 \times 10^{-3} \text{ m} = 25.15 \text{ mm} \quad d_{AB} = 2c = 50.3 \text{ mm} \quad \blacktriangleleft$$

$$\text{Rod BC: } c^3 = \frac{(2)(1250)}{\pi(25 \times 10^6)} = 31.831 \times 10^{-6} \text{ m}^3$$

$$c = 31.69 \times 10^{-3} \text{ m} = 31.69 \text{ mm} \quad d_{BC} = 2c = 63.4 \text{ mm} \quad \blacktriangleleft$$

PROBLEM 3.20

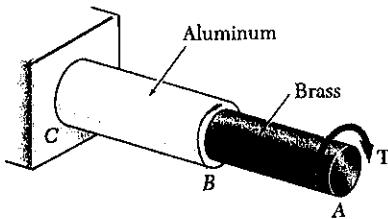

3.20 The solid rod *BC* has a diameter of 30 mm and is made an aluminum for which the allowable shearing stress is 25 MPa. Rod *AB* is hollow and has an outer diameter of 25 mm; it is made a brass for which the allowable shearing stress is 50 MPa. Determine (a) the largest inner diameter of rod *AB* for which the factor of safety is the same for each rod, (b) the largest torque that may be applied at *A*.

SOLUTION

$$\text{Solid rod BC: } \tau = \frac{Tc}{J} \quad J = \frac{\pi}{2} c^4$$

$$\tau_{\text{all}} = 25 \times 10^6 \text{ Pa} \quad c = \frac{1}{2} d = 0.015 \text{ m}$$

$$T_{\text{all}} = \frac{\pi}{2} c^3 \tau_{\text{all}} = \frac{\pi}{2} (0.015)^3 (25 \times 10^6) = 132.536 \text{ N}\cdot\text{m}$$

$$\text{Hollow rod AB: } \tau_{\text{all}} = 50 \times 10^6 \text{ Pa} \quad T_{\text{all}} = 132.536 \text{ N}\cdot\text{m}$$

$$c_2 = \frac{1}{2} d_2 = \frac{1}{2} (0.025) = 0.0125 \text{ m} \quad c_1 = ?$$

$$T_{\text{all}} = \frac{J \tau_{\text{all}}}{c_2} = \frac{\pi}{2} (c_2^4 - c_1^4) \frac{\tau_{\text{all}}}{c_2}$$

$$c_1^4 = c_2^4 - \frac{2T_{\text{all}} c_2}{\pi \tau_{\text{all}}} = 0.0125^4 - \frac{(2)(132.536)(0.0125)}{\pi(50 \times 10^6)} = 3.3203 \times 10^{-9} \text{ m}^4$$

$$c_1 = 7.59 \times 10^{-3} \text{ m} = 7.59 \text{ mm} \quad d_1 = 2c_1 = 15.18 \text{ mm} \quad \blacktriangleleft$$

$$\text{Allowable torque } T_{\text{all}} = 132.5 \text{ N}\cdot\text{m} \quad \blacktriangleleft$$

PROBLEM 3.21

3.21 A torque of magnitude $T = 1000 \text{ N}\cdot\text{m}$ is applied at D as shown. Knowing that the diameter of shaft AB is 56 mm and the diameter of shaft CD is 42 mm , determine the maximum shearing stress in (a) shaft AB , (b) shaft CD .

SOLUTION

$$T_{CD} = 1000 \text{ N}\cdot\text{m}$$

$$T_{AB} = \frac{r_B}{r_C} T_{CD} = \frac{100}{40} (1000) = 2500 \text{ N}\cdot\text{m}$$

Shaft AB : $c = \frac{1}{2}d = 0.028 \text{ m}$

$$\tau = \frac{Tc}{J} = \frac{2T}{\pi c^3} = \frac{(2)(2500)}{\pi (0.028)^3} = 72.50 \times 10^6 \quad 72.5 \text{ MPa} \blacktriangleleft$$

Shaft BC : $c = \frac{1}{2}d = 0.020 \text{ m}$

$$\tau = \frac{Tc}{J} = \frac{2T}{\pi c^3} = \frac{(2)(1000)}{\pi (0.020)^3} = 68.7 \times 10^6 \quad 68.7 \text{ MPa} \blacktriangleleft$$

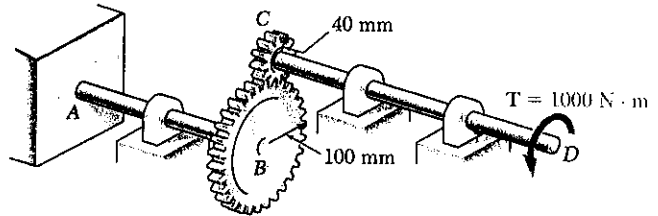

PROBLEM 3.22

3.22 A torque of magnitude $T = 1000 \text{ N}\cdot\text{m}$ is applied at D as shown. Knowing that the allowable shearing stress is 60 MPa in each shaft, determine the required diameter of (a) shaft AB , (b) shaft CD .

SOLUTION

$$T_{CD} = 1000 \text{ N}\cdot\text{m}$$

$$T_{AB} = \frac{r_B}{r_C} T_{CD} = \frac{100}{40} (1000) = 2500 \text{ N}\cdot\text{m}$$

Shaft AB : $\tau_{all} = 60 \times 10^6 \text{ Pa}$

$$\tau = \frac{Tc}{J} = \frac{2T}{\pi c^3} \quad c^3 = \frac{2T}{\pi \tau} = \frac{(2)(2500)}{\pi (60 \times 10^6)} = 26.526 \times 10^{-6} \text{ m}^3$$

$$c = 29.82 \times 10^{-3} = 29.82 \text{ mm} \quad d = 2c = 59.6 \text{ mm} \quad \blacktriangleleft$$

Shaft CD : $\tau_{all} = 60 \times 10^6 \text{ Pa}$

$$\tau = \frac{Tc}{J} = \frac{2T}{\pi c^3} \quad c^3 = \frac{2T}{\pi \tau} = \frac{(2)(1000)}{\pi (60 \times 10^6)} = 10.610 \times 10^{-6} \text{ m}^3$$

$$c = 21.97 \times 10^{-3} \text{ m} = 21.97 \text{ mm} \quad d = 2c = 43.9 \text{ mm} \quad \blacktriangleleft$$

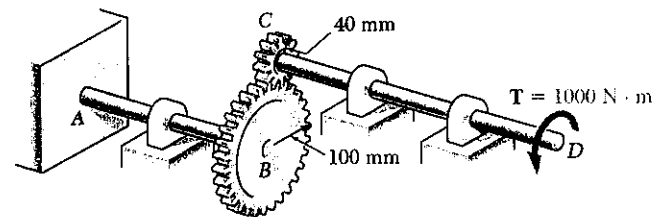

PROBLEM 3.23

3.23 and 3.24 Under normal operating conditions a motor exerts a torque of magnitude $T_F = 1200 \text{ lb}\cdot\text{in.}$ at F . Knowing that the allowable shearing stress is 10.5 ksi in each shaft, for the given data, determine the required diameter of (a) shaft CDE, (b) shaft FGH.

3.23 $r_D = 8 \text{ in.}, r_G = 3 \text{ in.}$

SOLUTION

$$T_F = 1200 \text{ lb}\cdot\text{in}$$

$$T_E = \frac{r_D}{r_G} T_F = \frac{8}{3} (1200) = 3200 \text{ lb}\cdot\text{in}$$

$$\tau_{\text{all}} = 10.5 \text{ ksi} = 10500 \text{ psi}$$

$$\tau = \frac{Tc}{J} = \frac{2T}{\pi c^3}, \quad c^3 = \frac{2T}{\pi \tau}$$

(a) Shaft CDE

$$c^3 = \frac{(2)(3200)}{\pi(10500)} = 0.194012 \text{ in}^3$$

$$c = 0.5789 \quad d_{DE} = 2c = 1.158 \text{ in.}$$

(b) Shaft FGH

$$c^3 = \frac{(2)(1200)}{\pi(10500)} = 0.072757 \text{ in}^3$$

$$c = 0.4174 \text{ in} \quad d_{FG} = 2c = 0.835 \text{ in}$$

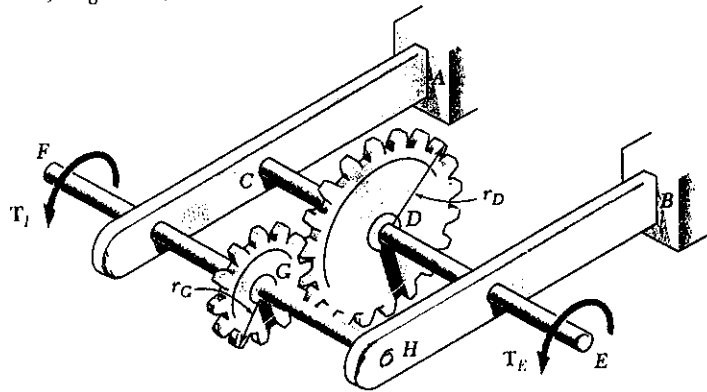

PROBLEM 3.24

3.23 and 3.24 Under normal operating conditions a motor exerts a torque of magnitude $T_F = 1200 \text{ lb}\cdot\text{in.}$ at F . Knowing that the allowable shearing stress is 10.5 ksi in each shaft, for the given data, determine the required diameter of (a) shaft CDE, (b) shaft FGH.

3.24 $r_D = 3 \text{ in.}, r_G = 8 \text{ in.}$

SOLUTION

$$T_F = 1200 \text{ lb}\cdot\text{in}$$

$$T_E = \frac{r_D}{r_G} T_F = \frac{3}{8} (1200) = 450 \text{ lb}\cdot\text{in.}$$

$$\tau_{\text{all}} = 10.5 \text{ ksi} = 10500 \text{ psi}$$

$$\tau = \frac{Tc}{J} = \frac{2T}{\pi c^3}, \quad c^3 = \frac{2T}{\pi \tau}$$

Shaft CDE

$$c^3 = \frac{(2)(450)}{\pi(10500)} = 0.027284 \text{ in}^3$$

$$c = 0.30105 \text{ in} \quad d_{DE} = 2c = 0.602 \text{ in}$$

Shaft FGH

$$c^3 = \frac{(2)(1200)}{\pi(10500)} = 0.072757 \text{ in}^3$$

$$c = 0.4174 \text{ in.} \quad d_{FG} = 2c = 0.835 \text{ in}$$

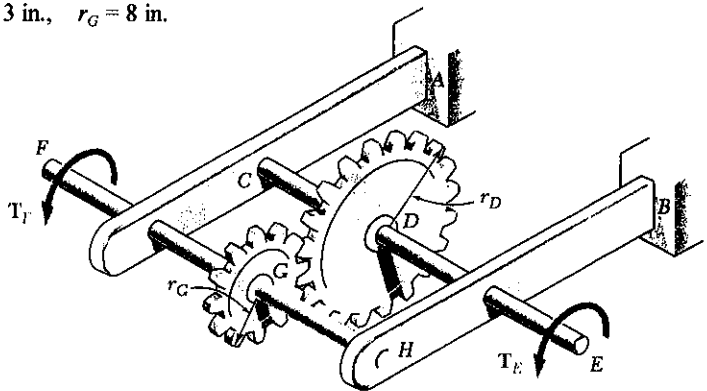

PROBLEM 3.25

3.25 Under normal operating conditions a motor exerts a torque of magnitude T_F at F . The shafts are made of a steel for which the allowable shearing stress is 12 ksi and have diameters of $d_{CDE} = 0.900$ in. and $d_{FGH} = 0.800$ in. Knowing that $r_D = 6.5$ in. and $r_G = 4.5$ in., determine the largest torque T_F which may be exerted at F .

SOLUTION

$$\tau_{all} = 12 \text{ ksi}$$

Shaft FG: $c = \frac{1}{2}d = 0.400$ in

$$T_{F,all} = \frac{J \tau_{all}}{c} = \frac{\pi}{2} c^3 \tau_{all}$$

$$= \frac{\pi}{2} (0.400)^3 (12) = 1.206 \text{ kip}\cdot\text{in.}$$

Shaft DE: $c = \frac{1}{2}d = 0.450$ in

$$T_{E,all} = \frac{\pi}{2} c^3 \tau_{all}$$

$$= \frac{\pi}{2} (0.450)^3 (12) = 1.7177 \text{ kip}\cdot\text{in}$$

$$T_F = \frac{r_G}{r_D} T_E \quad T_{F,all} = \frac{4.5}{6.5} (1.7177) = 1.189 \text{ kip}\cdot\text{in}$$

Allowable value of T_F is the smaller

$$T_{F,all} = 1.189 \text{ kip}\cdot\text{in} \blacktriangleleft$$

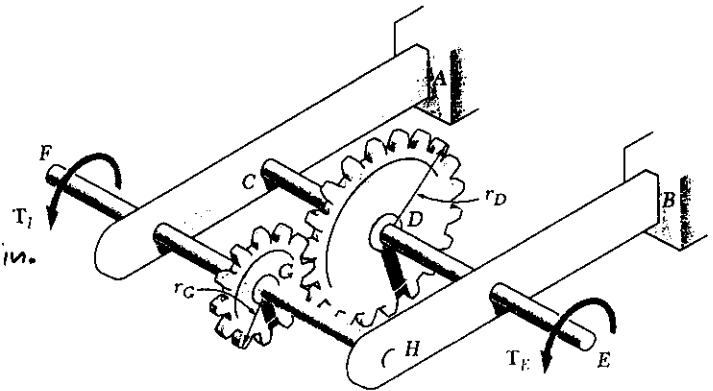

PROBLEM 3.26

3.26 The two solid shafts are connected by gears as shown and are made of a steel for which the allowable shearing stress is 60 MPa. Knowing that a 600 N·m-torque T_C is applied at C , determine the required diameter of (a) shaft BC, (b) shaft EF.

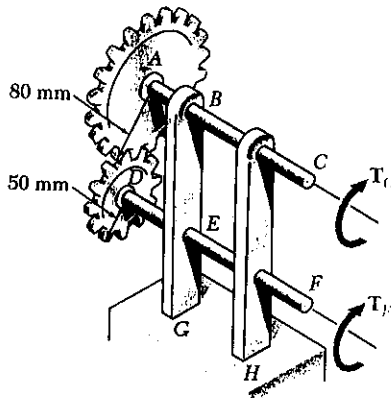

SOLUTION

Shaft BC: $T_C = 600 \text{ N}\cdot\text{m}$, $\tau_{max} = 60 \times 10^6 \text{ Pa}$

$$\tau = \frac{Tc}{J} = \frac{2T}{\pi c^3}$$

$$c^3 = \frac{2T}{\pi \tau} = \frac{(2)(600)}{\pi(60 \times 10^6)} = 6.3662 \times 10^{-6} \text{ m}^3$$

$$c = 18.53 \times 10^{-3} \text{ m} = 18.53 \text{ mm}, \quad d_{BC} = 2c = 37.1 \text{ mm} \blacktriangleleft$$

Shaft EF: $T_F = \frac{r_D}{r_A} T_C = \frac{50}{80} (600) = 375 \text{ N}\cdot\text{m}$

$$\tau = \frac{Tc}{J} = \frac{2T}{\pi c^3}$$

$$c^3 = \frac{2T}{\pi \tau} = \frac{(2)(375)}{\pi(60 \times 10^6)} = 3.9787 \times 10^{-6} \text{ m}^3$$

$$c = 15.85 \times 10^{-3} \text{ m} = 15.85 \text{ mm}, \quad d_{EF} = 2c = 31.7 \text{ mm} \blacktriangleleft$$

PROBLEM 3.27

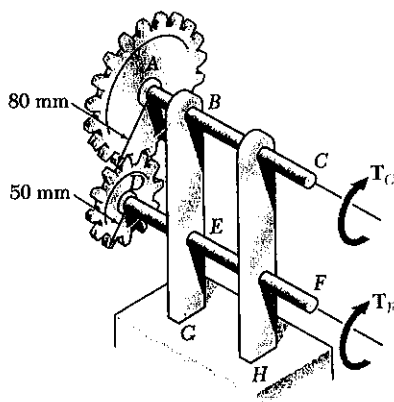

3.27 The two solid shafts are connected by gears as shown and are made of a steel for which the allowable shearing stress is 50 MPa. Knowing that the diameters of the two shafts are, respectively, $d_{BC} = 40$ mm and $d_{EF} = 32$ mm, determine the largest torque T_C which may be applied at C.

SOLUTION

Shaft AC: $\tau_{max} = 50 \times 10^6 \text{ Pa}$, $c = \frac{1}{2}d = 0.020 \text{ m}$
 $T_C = \frac{J\tau}{c} = \frac{\pi}{2}c^3\tau = \frac{\pi}{2}(0.020)^3(50 \times 10^6)$
 $= 628.3 \text{ N}\cdot\text{m}$

Shaft DF: $\tau_{max} = 50 \times 10^6 \text{ Pa}$, $c = \frac{1}{2}d = 0.016 \text{ m}$
 $T_F = \frac{J\tau}{c} = \frac{\pi}{2}c^3\tau = \frac{\pi}{2}(0.016)^3(50 \times 10^6)$
 $= 321.7 \text{ N}\cdot\text{m}$

From Statics: $T_C = \frac{r_A}{r_D} T_F = \frac{80}{50} (321.7) = 514.7 \text{ N}\cdot\text{m}$

Allowable value of T_C is the smaller, i.e. $T_F = 515 \text{ N}\cdot\text{m}$ ◀

PROBLEM 3.28

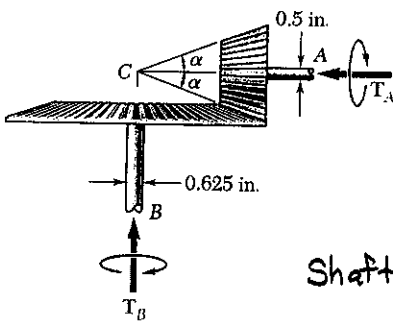

3.28 In the bevel-gear system shown $\alpha = 18.43^\circ$. Knowing that the allowable shearing stress is 8 ksi in each shaft, determine the largest torque T_A which may be applied at A.

SOLUTION

Shaft A: $\tau = 8 \text{ ksi}$ $c = \frac{1}{2}d = 0.25 \text{ in}$

$T_A = \frac{J\tau}{c} = \frac{\pi}{2}c^3\tau = \frac{\pi}{2}(0.25)^3(8) = 0.19635 \text{ kip}\cdot\text{in}$

Shaft B: $\tau = 8 \text{ ksi}$ $c = \frac{1}{2}d = 0.3125 \text{ in}$

$T_B = \frac{J\tau}{c} = \frac{\pi}{2}c^3\tau = \frac{\pi}{2}(0.3125)^3(8) = 0.3885 \text{ kip}\cdot\text{in}$

From Statics: $T_A = \frac{r_A}{r_B} T_B = (\tan \alpha) T_B = (\tan 18.43^\circ)(0.3885)$
 $= 0.12779 \text{ kip}\cdot\text{in}$

Allowable value of T_A is the smaller

$T_A = 0.1278 \text{ kip}\cdot\text{in} = 127.8 \text{ lb}\cdot\text{in}$ ◀

PROBLEM 3.29

3.29 (a) For a given allowable stress, determine the ratio T/w of the maximum allowable torque T and the weight per unit length w for the hollow shaft shown. (b) Denoting by $(T/w)_0$ the value of this ratio computed for a solid shaft of the same radius c_2 , express the ratio T/w for the hollow shaft in terms of $(T/w)_0$ and c_1/c_2 .

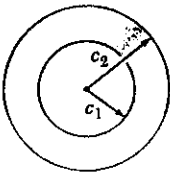

SOLUTION

w = weight per unit length, γ = specific weight

W = total weight, L = length

$$w = \frac{W}{L} = \frac{\gamma LA}{L} = \gamma A = \gamma \pi (c_2^2 - c_1^2)$$

$$T = \frac{J \tau_{al}}{c_2} = \frac{\pi}{2} \frac{c_2^4 - c_1^4}{c_2} \tau_{al} = \frac{\pi}{2} \frac{(c_2^2 + c_1^2)(c_2^2 - c_1^2)}{c_2} \tau_{al}$$

$$\left(\frac{T}{w}\right)_h = \frac{(c_2^2 + c_1^2) \tau_{al}}{2\gamma c_2} = \frac{c_2 \tau_{al}}{2\gamma} \left(1 + \frac{c_1^2}{c_2^2}\right) \quad (\text{hollow shaft}) \quad \blacktriangleleft$$

$$c_1 = 0 \text{ for solid shaft} \quad \left(\frac{T}{w}\right)_0 = \frac{c_2 \tau_{al}}{2\gamma} \quad (\text{solid shaft})$$

$$\frac{(T/w)_h}{(T/w)_0} = 1 + \frac{c_1^2}{c_2^2} \quad \left(\frac{T}{w}\right)_h = \left(\frac{T}{w}\right)_0 \left(1 + \frac{c_1^2}{c_2^2}\right) \quad \blacktriangleleft$$

PROBLEM 3.30

3.30 While the exact distribution of the shearing stresses in a hollow cylinder shaft is as shown in Fig. (1), an approximate value may be obtained for τ_{max} by assuming the stresses to be uniformly distributed over the area A of the cross section, as shown in Fig. (2), and then further assuming that all the elementary shearing forces act a distance from O equal to the mean radius $r_m = \frac{1}{2}(c_1 + c_2)$ of the cross section. This approximate value is $\tau_0 = T/Ar_m$, where T is the applied torque. Determine the ratio τ_{max}/τ_0 of the true value of the maximum shearing stress and its approximate value τ_0 for values of c_1/c_2 respectively equal to 1.00, 0.95, 0.75, 0.50, and 0.

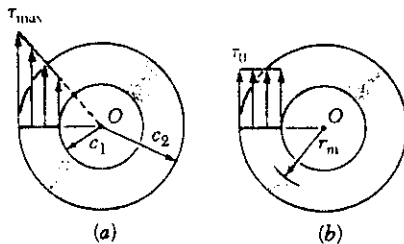

SOLUTION

$$\begin{aligned} \text{For a hollow shaft: } \tau_{max} &= \frac{Tc_2}{J} = \frac{2Tc_2}{\pi(c_2^4 - c_1^4)} = \frac{2Tc_2}{\pi(c_2^2 - c_1^2)(c_2^2 + c_1^2)} \\ &= \frac{2Tc_2}{A(c_2^2 + c_1^2)} \end{aligned}$$

$$\text{By definition } \tau_0 = \frac{T}{Ar_m} = \frac{2T}{A(c_2 + c_1)}$$

$$\text{Dividing } \frac{\tau_{max}}{\tau_0} = \frac{c_2(c_2 + c_1)}{c_2^2 + c_1^2} = \frac{1 + (c_1/c_2)}{1 + (c_1/c_2)^2} \quad \blacktriangleleft$$

c_1/c_2	1.0	0.95	0.75	0.5	0.0
τ_{max}/τ_0	1.0	1.025	1.120	1.200	1.0

PROBLEM 3.31

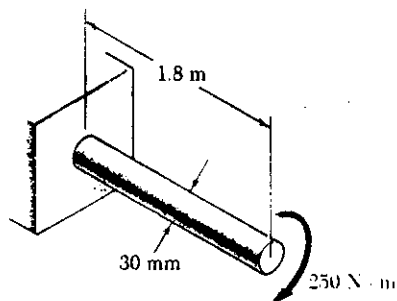

3.31 (a) For the solid steel shaft shown ($G = 77 \text{ GPa}$), determine the angle of twist at A . (b) Solve part a , assuming that the steel shaft is hollow with a 30-mm outer diameter and a 20-mm inner diameter.

SOLUTION

$$(a) \quad c = \frac{1}{2}d = 0.015 \text{ m}, \quad J = \frac{\pi}{2}c^4 = \frac{\pi}{2}(0.015)^4$$

$$J = 79.522 \times 10^{-9} \text{ m}^4, \quad L = 1.8 \text{ m}, \quad G = 77 \times 10^9 \text{ Pa}$$

$$T = 250 \text{ N}\cdot\text{m} \quad \phi = \frac{TL}{GJ}$$

$$\phi = \frac{(250)(1.8)}{(77 \times 10^9)(79.522 \times 10^{-9})} = 73.49 \times 10^{-3} \text{ rad}$$

$$\phi = \frac{(73.49 \times 10^{-3})180}{\pi} = 4.21^\circ$$

$$(b) \quad c_2 = 0.015 \text{ m}, \quad c_1 = \frac{1}{2}d_1 = 0.010 \text{ m}, \quad J = \frac{\pi}{2}(c_2^4 - c_1^4)$$

$$J = \frac{\pi}{2}(0.015^4 - 0.010^4) = 63.814 \times 10^{-9} \text{ m}^4 \quad \phi = \frac{TL}{GJ}$$

$$\phi = \frac{(250)(1.8)}{(77 \times 10^9)(63.814 \times 10^{-9})} = 91.58 \times 10^{-3} \text{ rad} = \frac{180}{\pi}(91.58 \times 10^{-3}) = 5.25^\circ$$

PROBLEM 3.32

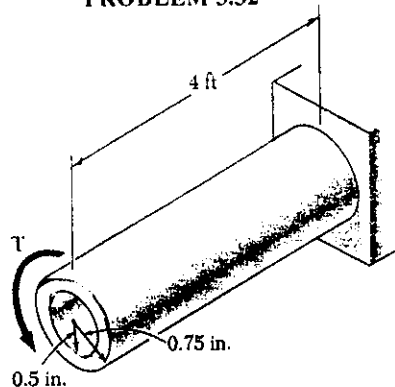

3.32 For the aluminum shaft shown ($G = 3.9 \times 10^6 \text{ psi}$), determine (a) the torque T which causes an angle of twist of 5° , (b) the angle of twist caused by the same torque T in a solid cylindrical shaft of the same length and cross-sectional area.

SOLUTION

$$(a) \quad \phi = \frac{TL}{GJ}, \quad T = \frac{GJ\phi}{L}$$

$$\phi = 5^\circ = 87.266 \times 10^{-3} \text{ rad}, \quad L = 4 \text{ ft} = 48 \text{ in}$$

$$J = \frac{\pi}{2}(c_2^4 - c_1^4) = \frac{\pi}{2}(0.75^4 - 0.5^4) = 0.39884 \text{ in}^4$$

$$T = \frac{(3.9 \times 10^6)(0.39884)(87.266 \times 10^{-3})}{48}$$

$$= 2.8279 \times 10^3 \text{ lb}\cdot\text{in} = 2.83 \text{ kip}\cdot\text{in}$$

(b) Hollow shaft $A = \pi(c_2^2 - c_1^2)$ Solid shaft $A = \pi c^2$

Matching areas $c^2 = c_2^2 - c_1^2 = 0.75^2 - 0.5^2 = 0.3125 \text{ in}^2$

$$c = 0.5590 \text{ in}, \quad J = \frac{\pi}{2}c^4 = \frac{\pi}{2}(0.5590)^4 = 153.398 \times 10^{-3} \text{ in}^4$$

$$\phi = \frac{TL}{GJ} = \frac{(2.8279 \times 10^3)(48)}{(3.9 \times 10^6)(153.398 \times 10^{-3})} = 226.89 \times 10^{-3} \text{ rad}$$

$$= 13.00^\circ$$

PROBLEM 3.33

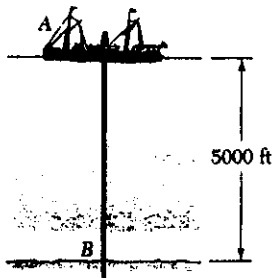

3.33 The ship at *A* has just started to drill for oil on the ocean floor at a depth of 5000 ft. Knowing that the top of the 8-in.-diameter steel drill pipe ($G = 11.2 \times 10^6$ psi) rotates through two complete revolutions before the drill bit at *B* starts to operate, determine the maximum shearing stress caused in the pipe by torsion.

SOLUTION

$$\phi = \frac{T L}{G J} \quad T = \frac{G J \phi}{L}$$

$$\tau = \frac{T c}{J} = \frac{G J \phi c}{J L} = \frac{G \phi c}{L}$$

$$\phi = 2 \text{ rev} = (2)(2\pi) = 12.566 \text{ rad}, \quad c = \frac{1}{2}d = 4.0 \text{ in}$$

$$L = 5000 \text{ ft} = 60000 \text{ in} \quad \tau = \frac{(11.2 \times 10^6)(12.566)(4.0)}{60000}$$

$$= 9.3826 \times 10^3 \text{ psi} = 9.38 \text{ ksi}$$

PROBLEM 3.34

3.34 Determine the largest allowable diameter of a 3-m-long steel rod ($G = 77$ GPa) if the rod is to be twisted through 30° without exceeding a shearing stress of 80 MPa.

SOLUTION

$$L = 3 \text{ m}, \quad \phi = \frac{30 \pi}{180} = 523.6 \times 10^{-3} \text{ rad}, \quad \tau = 80 \times 10^6 \text{ Pa}$$

$$\phi = \frac{T L}{G J}, \quad T = \frac{G J \phi}{L}, \quad \tau = \frac{T c}{J} = \frac{G J \phi c}{J L} = \frac{G \phi c}{L}, \quad c = \frac{\tau L}{G \phi}$$

$$c = \frac{(80 \times 10^6)(3.0)}{(77 \times 10^9)(523.6 \times 10^{-3})} = 5.953 \times 10^{-3} \text{ m} = 5.953 \text{ mm}$$

$$d = 2c = 11.91 \text{ mm}$$

PROBLEM 3.35

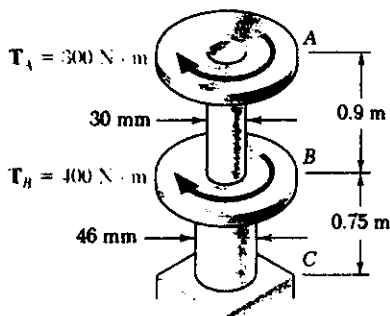

3.35 The torques shown are exerted on pulleys *A* and *B*. Knowing that the shafts are solid and made of aluminum ($G = 77$ GPa), determine the angle of twist between (a) *A* and *B*, (b) *A* and *C*.

SOLUTION

$$(a) \quad T_{AB} = 300 \text{ N}\cdot\text{m}, \quad L_{AB} = 0.9 \text{ m}, \quad c_{AB} = \frac{1}{2}d = 0.015 \text{ m}$$

$$J_{AB} = \frac{\pi}{2} (0.015)^4 = 79.522 \times 10^{-9} \text{ m}^4$$

$$\phi_{AB} = \frac{T_{AB} L_{AB}}{G J} = \frac{(300)(0.9)}{(77 \times 10^9)(79.522 \times 10^{-9})} = 44.095 \times 10^{-3} \text{ rad}$$

$$\phi_{AB} = 2.53^\circ$$

$$(b) \quad T_{BC} = 300 + 400 = 700 \text{ N}\cdot\text{m}, \quad L_{BC} = 0.75 \text{ m}, \quad c_{BC} = \frac{1}{2}d = 0.023 \text{ m}$$

$$J_{BC} = \frac{\pi}{2} (0.023)^4 = 439.573 \times 10^{-9} \text{ m}^4$$

$$\phi_{BC} = \frac{T_{BC} L_{BC}}{G J_{BC}} = \frac{(700)(0.75)}{(77 \times 10^9)(439.573 \times 10^{-9})} = 15.511 \times 10^{-3} \text{ rad}$$

$$\phi_{AC} = \phi_{AB} + \phi_{BC} = 59.606 \times 10^{-3} \text{ rad} = 3.42^\circ$$

PROBLEM 3.36

3.36 The torques shown are exerted on pulleys B, C and D. Knowing that the entire shaft is made of steel ($G = 27 \text{ GPa}$), determine the angle of twist between (a) C and B, (b) D and B.

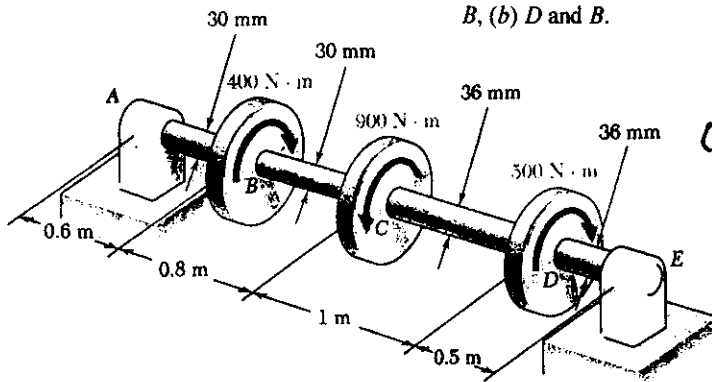

SOLUTION

(a) Shaft BC: $c = \frac{1}{2}d = 0.015 \text{ m}$
 $J_{BC} = \frac{\pi}{2}c^4 = 79.522 \times 10^{-9} \text{ m}^4$
 $L_{BC} = 0.8 \text{ m}, G = 27 \times 10^9 \text{ Pa}$
 $\phi_{BC} = \frac{TL}{GJ} = \frac{(400)(0.8)}{(27 \times 10^9)(79.522 \times 10^{-9})}$
 $= 0.149904 \text{ rad} = 8.54^\circ$

(b) Shaft CD: $c = \frac{1}{2}d = 0.018 \text{ m}$ $J_{CD} = \frac{\pi}{2}c^4 = 164.896 \times 10^{-9} \text{ m}^4$
 $L_{CD} = 1.0 \text{ m}$ $T_{CD} = 400 - 900 = -500 \text{ N}\cdot\text{m}$
 $\phi_{CD} = \frac{TL}{GJ} = \frac{(-500)(1.0)}{(27 \times 10^9)(164.896 \times 10^{-9})} = -0.11230 \text{ rad}$
 $\phi_{BD} = \phi_{BC} + \phi_{CD} = 0.14904 - 0.11230 = 0.03674 \text{ rad} = 2.11^\circ$

PROBLEM 3.37

3.37 The solid brass rod AB ($G = 39 \text{ GPa}$) is bonded to the solid aluminum rod BC ($G = 27 \text{ GPa}$). Determine the angle of twist (a) at B, (b) at A.

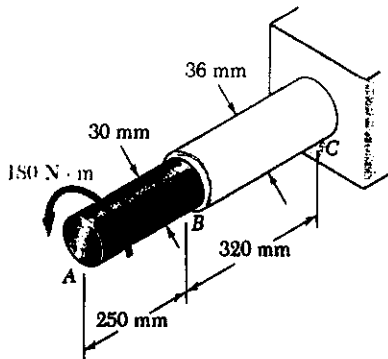

SOLUTION

Shaft AB: $c = \frac{1}{2}d = 0.015 \text{ m}$ $L = 0.250 \text{ m}$
 $G = 39 \times 10^9 \text{ Pa}$ $T = 180 \text{ N}\cdot\text{m}$
 $J = \frac{\pi}{2}c^4 = 79.522 \times 10^{-9} \text{ m}^4$

$\phi_{AB} = \frac{TL}{GJ} = \frac{(180)(0.250)}{(39 \times 10^9)(79.522 \times 10^{-9})} = 14.510 \times 10^{-3} \text{ rad}$

Shaft BC: $c = \frac{1}{2}d = 0.018 \text{ m}, L = 0.320 \text{ m}$
 $G = 27 \times 10^9 \text{ Pa}, T = 180 \text{ N}\cdot\text{m}$
 $J = \frac{\pi}{2}c^4 = 164.896 \times 10^{-9} \text{ m}^4$

$\phi_{BC} = \frac{(180)(0.320)}{(27 \times 10^9)(164.896 \times 10^{-9})} = 12.937 \times 10^{-3} \text{ rad}$

Answers: (a) $\phi_B = \phi_{BC} = 12.937 \times 10^{-3} \text{ rad} = 0.741^\circ$

(b) $\phi_A = \phi_{BC} + \phi_{AB} = 27.447 \times 10^{-3} \text{ rad} = 1.573^\circ$

PROBLEM 3.38

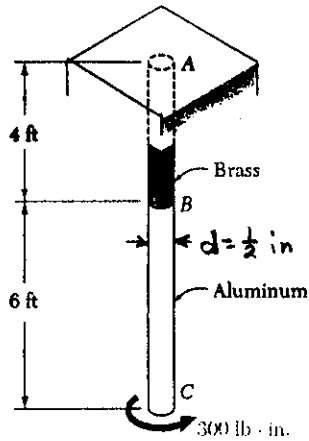

3.38 The brass rod AB ($G = 5.6 \times 10^6$ psi) is bonded to the aluminum rod BC ($G = 3.9 \times 10^6$ psi). Knowing that each rod is solid, determine the angle of twist (a) at B , (b) at C .

SOLUTION

Both portions $c = \frac{1}{2}d = 0.25$ in
 $J = \frac{\pi}{2}c^4 = 6.1359 \times 10^{-3}$ in⁴ $T = 300$ lb·in

Shaft AB : $G_{AB} = 5.6 \times 10^6$ psi $L_{AB} = 4$ ft = 48 in

$$\phi_B = \phi_{AB} = \frac{T L_{AB}}{G_{AB} J} = \frac{(300)(48)}{(5.6 \times 10^6)(6.1359 \times 10^{-3})}$$

$$= 0.419 \text{ rad} = 24.0^\circ$$

Shaft BC : $G = 3.9 \times 10^6$ psi $L_{BC} = 6$ ft = 72 in

$$\phi_{BC} = \frac{T L_{BC}}{G_{BC} J} = \frac{(300)(72)}{(3.9 \times 10^6)(6.1359 \times 10^{-3})}$$

$$= 0.903 \text{ rad} = 51.7^\circ$$

$$\phi_C = \phi_B + \phi_{BC}$$

$$= 0.417 + 0.903 = 1.320 \text{ rad} = 75.6^\circ$$

[Www.iepnu.ir](http://www.iepnu.ir)



PROBLEM 3.39

3.39 Two solid steel shafts ($G = 77 \text{ GPa}$) are connected by the gears shown. Knowing that the radius of gear B is $r_B = 20 \text{ mm}$, determine the angle through which end A rotates when $T_A = 75 \text{ N}\cdot\text{m}$.

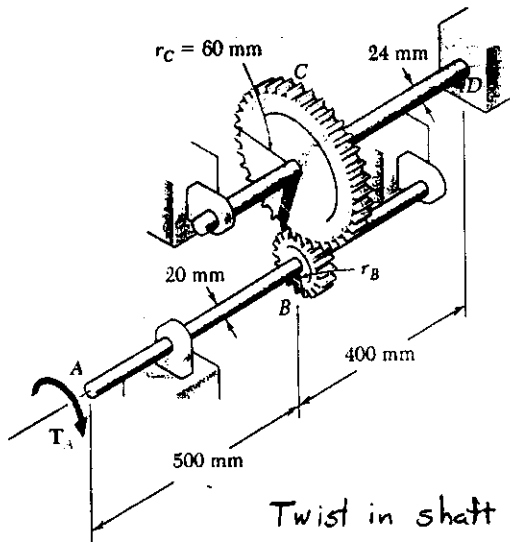

SOLUTION

Calculation of torques.

Circumferential contact force between gears B and C

$$F = \frac{T_{AB}}{r_B} = \frac{T_{CD}}{r_C} \quad \therefore T_{CD} = \frac{r_C}{r_B} T_{AB}$$

$$T_{AB} = T_A = 75 \text{ N}\cdot\text{m}$$

$$T_{CD} = \frac{0.060}{0.020} (75) = 225 \text{ N}\cdot\text{m}$$

Twist in shaft CD

$$J_{CD} = \frac{\pi}{2} C_{CD}^4 = \frac{\pi}{2} (0.012)^4 = 32.572 \times 10^{-9} \text{ m}^4, \quad L_{CD} = 0.400 \text{ m}$$

$$G = 77 \times 10^9 \text{ Pa}, \quad \phi_{CD} = \frac{TL}{GJ} = \frac{(225)(0.400)}{(77 \times 10^9)(32.572 \times 10^{-9})} = 35.885 \times 10^{-3} \text{ rad.}$$

Rotation angle at C $\phi_C = \phi_{CD} = 35.885 \times 10^{-3} \text{ rad}$

Circumferential displacement at contact points of gears B and C

$$s = r_C \phi_C = r_B \phi_B$$

Rotation angle at B: $\phi_B = \frac{r_C}{r_B} \phi_C = \frac{0.060}{0.020} (35.885 \times 10^{-3}) = 107.654 \times 10^{-3} \text{ rad}$

Twist in shaft AB:

$$J_{AB} = \frac{\pi}{2} C_{AB}^4 = \frac{\pi}{2} (0.010)^4 = 15.708 \times 10^{-9} \text{ m}^4, \quad L_{AB} = 0.500 \text{ m}$$

$$G = 77 \times 10^9 \text{ Pa}, \quad \phi_{AB} = \frac{TL}{GJ} = \frac{(75)(0.500)}{(77 \times 10^9)(15.708 \times 10^{-9})} = 31.004 \times 10^{-3} \text{ rad}$$

Rotation at A $\phi_A = \phi_B + \phi_{AB} = 138.7 \times 10^{-3} \text{ rad} = 7.94^\circ$

PROBLEM 3.40

3.40 Solve Prob. 3.39, assuming that a change in design of the assembly resulted in the radius of gear B being increased to 30 mm.

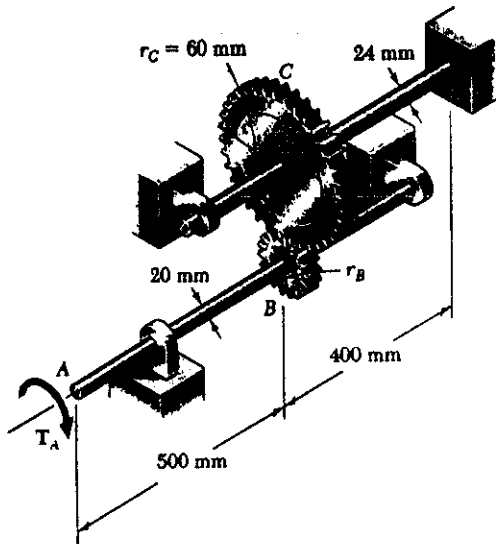

$G = 77 \text{ GPa}$, $r_B = 30 \text{ mm}$, $T_A = 75 \text{ N}\cdot\text{m}$
 Determine the angle through which end A rotates.

SOLUTION

Calculation of torques

Circumferential contact force between gears B and C

$$F = \frac{T_{AB}}{r_B} = \frac{T_{CO}}{r_C} \therefore T_{CO} = \frac{r_C}{r_B} T_{AB}$$

$$T_{AB} = T_A = 75 \text{ N}\cdot\text{m}$$

$$T_{CO} = \frac{0.060}{0.030} (75) = 150 \text{ N}\cdot\text{m}$$

Twist in shaft CD

$$J_{CD} = \frac{\pi}{2} C_{CD}^4 = \frac{\pi}{2} (0.012)^4 = 32.572 \times 10^{-9} \text{ m}^4, \quad L_{CD} = 0.400 \text{ m}$$

$$G = 77 \times 10^9 \text{ Pa}, \quad \phi_{CD} = \frac{TL}{GJ} = \frac{(150)(0.400)}{(77 \times 10^9)(32.572 \times 10^{-9})} = 23.923 \times 10^{-3} \text{ rad}$$

Rotation angle at C $\phi_C = \phi_{CD} = 23.923 \times 10^{-3} \text{ rad}$.

Circumferential displacement at contact points of gears B and C.

$$s = r_C \phi_C = r_B \phi_B$$

Rotation angle at B $\phi_B = \frac{r_C}{r_B} \phi_C = \frac{0.060}{0.030} (23.923 \times 10^{-3}) = 47.846 \times 10^{-3} \text{ rad}$

Twist in shaft AB

$$J_{AB} = \frac{\pi}{2} C_{AB}^4 = \frac{\pi}{2} (0.010)^4 = 15.708 \times 10^{-9} \text{ m}^4, \quad L_{AB} = 0.500 \text{ m}$$

$$G = 77 \times 10^9 \text{ Pa}, \quad \phi_{AB} = \frac{TL}{GJ} = \frac{(75)(0.500)}{(77 \times 10^9)(15.708 \times 10^{-9})} = 31.004 \times 10^{-3} \text{ rad}$$

Rotation at A $\phi_A = \phi_B + \phi_{AB} = 78.85 \times 10^{-3} \text{ rad} = 4.52^\circ$ ◀

PROBLEM 3.41

3.41 Two shafts, each of $\frac{3}{4}$ -in. diameter, are connected by the gears shown. Knowing that $G = 11.2 \times 10^6$ psi and that the shaft at F is fixed, determine the angle through which end A rotates when a 750 lb-in. torque is applied at A .

SOLUTION

Calculation of torques

Circumferential contact force between gears B and E

$$F = \frac{T_{AB}}{r_B} = \frac{T_{EF}}{r_E}$$

$$\therefore T_{EF} = \frac{r_E}{r_B} T_{AB} = \frac{4}{3} (750) = 1000 \text{ lb-in.}$$

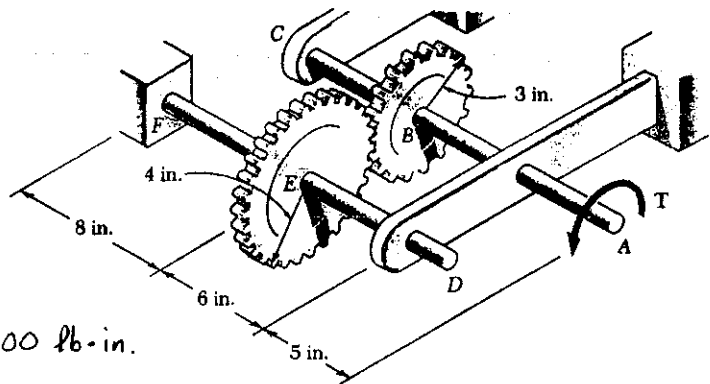

Twist in shaft FE

$$L_{FE} = 8 \text{ in.}, J_{FE} = \frac{\pi}{2} C^4 = \frac{\pi}{2} (0.375)^4 = 31.063 \times 10^{-3} \text{ in}^4, G = 11.2 \times 10^6 \text{ psi}$$

$$\phi_{FE} = \frac{T_{FE} L_{FE}}{G J_{FE}} = \frac{(1000)(8)}{(11.2 \times 10^6)(31.063 \times 10^{-3})} = 22.995 \times 10^{-3} \text{ rad}$$

Rotation at E $\phi_E = 22.995 \times 10^{-3} \text{ rad}$

Tangential displacement at gear circle $s = r_E \phi_E = r_B \phi_B$

Rotation at B $\phi_B = \frac{r_E}{r_B} \phi_E = \frac{4}{3} (22.995 \times 10^{-3}) = 30.660 \times 10^{-3} \text{ rad}$

Twist in shaft BA

$$L_{BA} = 6 + 5 = 11 \text{ in.}, J_{BA} = 31.063 \times 10^{-3} \text{ in}^4$$

$$\phi_{AB} = \frac{T_{AB} L_{BA}}{G J_{AB}} = \frac{(750)(11)}{(11.2 \times 10^6)(31.063 \times 10^{-3})} = 23.713 \times 10^{-3} \text{ rad}$$

Rotation at A

$$\phi_A = \phi_B + \phi_{AB} = 30.660 \times 10^{-3} + 23.713 \times 10^{-3} = 54.373 \times 10^{-3} \text{ rad}$$

$$= 3.12^\circ$$

PROBLEM 3.42

SOLUTION

Calculation of torques

Tangential contact force
between gears B and E

$$F = \frac{T_{AB}}{r_B} = \frac{T_{EF}}{r_E}$$

$$T_{EF} = \frac{r_E}{r_B} T_{AB} = \frac{3}{4} (750) = 562.5 \text{ lb}\cdot\text{in}$$

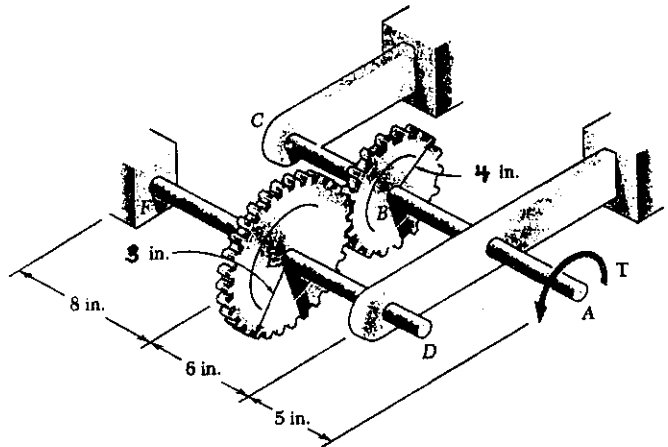

Twist in shaft FE

$$L_{FE} = 8 \text{ in.}, J_{FE} = \frac{\pi}{2} c^4 = \frac{\pi}{2} (0.375)^4 = 31.063 \times 10^{-3} \text{ in}^4 \quad G = 11.2 \times 10^6 \text{ psi}$$

$$\phi_{FE} = \frac{T_{FE} L_{FE}}{G J_{FE}} = \frac{(562.5)(8)}{(11.2 \times 10^6)(31.063 \times 10^{-3})} = 12.935 \times 10^{-3} \text{ rad}$$

Rotation at E $\phi_E = 12.935 \times 10^{-3} \text{ rad.}$

Tangential displacement at gear circle $S = r_E \phi_E = r_B \phi_B$

Rotation at B $\phi_B = \frac{r_E}{r_B} \phi_E = \frac{3}{4} (12.935 \times 10^{-3}) = 9.701 \times 10^{-3} \text{ rad}$

Twist shaft AB

$$L_{BA} = 6 + 5 = 11 \text{ in.}, J_{AB} = 31.063 \times 10^{-3} \text{ in}^4,$$

$$\phi_{AB} = \frac{T_{AB} L_{AB}}{G J_{AB}} = \frac{(750)(11)}{(11.2 \times 10^6)(31.063 \times 10^{-3})} = 23.713 \times 10^{-3} \text{ rad}$$

Rotation at A $\phi_A = \phi_B + \phi_{AB}$

$$= 9.701 \times 10^{-3} + 23.713 \times 10^{-3} = 33.414 \times 10^{-3} \text{ rad} = 1.914^\circ$$

PROBLEM 3.43

3.43 A coder F , used to record in digital form the rotation of shaft A , is connected to the shaft by means of the gear train shown, which consists of four gears and three solid steel shafts each of diameter d . Two of the gears have a radius r and the other two a radius nr . If the rotation of the coder F is prevented, determine in terms of T , l , G , J , and n the angle through which end A rotates.

SOLUTION

$$T_{AB} = T_A$$

$$T_{CD} = \frac{r_C}{r_B} T_{AB} = \frac{T_{AB}}{n} = \frac{T_A}{n}$$

$$T_{EF} = \frac{r_E}{r_D} T_{CD} = \frac{T_{CD}}{n} = \frac{T_A}{n^2}$$

$$\phi_E = \phi_{EF} = \frac{T_{EF} l_{EF}}{GJ} = \frac{T_A l}{n^2 GJ}$$

$$\phi_D = \frac{r_E}{r_D} \phi_E = \frac{\phi_E}{n} = \frac{T_A l}{n^3 GJ}$$

$$\phi_{CD} = \frac{T_{CD} l_{CD}}{GJ} = \frac{T_A l}{n GJ}$$

$$\phi_C = \phi_D + \phi_{CD} = \frac{T_A l}{n^3 GJ} + \frac{T_A l}{n GJ} = \frac{T_A l}{GJ} \left(\frac{1}{n^3} + \frac{1}{n} \right)$$

$$\phi_B = \frac{r_C}{r_B} \phi_C = \frac{\phi_C}{n} = \frac{T_A l}{GJ} \left(\frac{1}{n^4} + \frac{1}{n^2} \right)$$

$$\phi_{AB} = \frac{T_{AB} l_{AB}}{GJ} = \frac{T_A l}{GJ}$$

$$\phi_A = \phi_B + \phi_{AB} = \frac{T_A l}{GJ} \left(\frac{1}{n^4} + \frac{1}{n^2} + 1 \right)$$

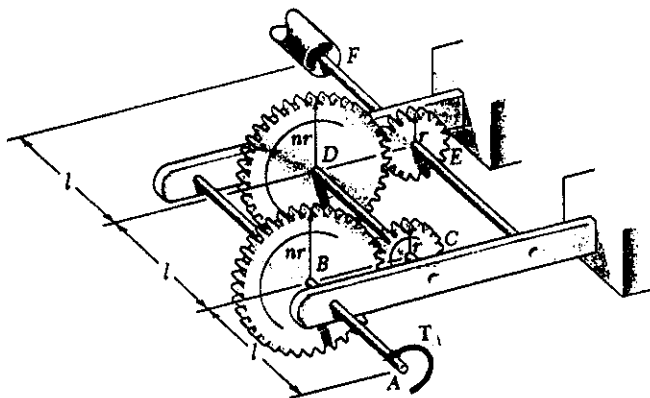

PROBLEM 3.44

3.43 A coder F , used to record in digital form the rotation of shaft A , is connected to the shaft by means of the gear train shown, which consists of four gears and three solid steel shafts each of diameter d . Two of the gears have a radius r and the other two a radius nr . If the rotation of the coder F is prevented, determine in terms of T , l , G , J , and n the angle through which end A rotates.

SOLUTION

See solution to PROBLEM 3.43 for development of equation for ϕ_A

3.44 For the gear train described in Prob. 3.43, determine the angle through which end A rotates when $T = 0.75 \text{ N}\cdot\text{m}$, $l = 60 \text{ mm}$, $d = 4 \text{ mm}$, $G = 77 \text{ GPa}$, and $n = 2$.

$$\phi_A = \frac{Tl}{GJ} \left(1 + \frac{1}{n^2} + \frac{1}{n^4} \right)$$

Data: $T = 0.75 \text{ N}\cdot\text{m}$, $l = 0.060 \text{ m}$, $c = \frac{1}{2}d = 0.002 \text{ m}$, $G = 77 \times 10^9 \text{ Pa}$

$n = 2$, $J = \frac{\pi}{2} c^4 = \frac{\pi}{2} (0.002)^4 = 25.133 \times 10^{-12} \text{ m}^4$

$$\phi_A = \frac{(0.75)(0.060)}{(77 \times 10^9)(25.133 \times 10^{-12})} \left(1 + \frac{1}{4} + \frac{1}{16} \right) = 30.52 \times 10^{-3} \text{ rad.}$$

$$= 1.749^\circ$$

PROBLEM 3.45

3.45 The design specifications of a 2-m-long solid circular transmission shaft require that the angle of twist of the shaft not exceed 3° when a torque of $9 \text{ kN}\cdot\text{m}$ is applied. Determine the required diameter of the shaft, knowing that the shaft is made of (a) a steel with an allowable shearing stress of 90 MPa and a modulus of rigidity of 77 GPa , (b) a bronze with an allowable shearing stress of 35 MPa and a modulus of rigidity of 42 GPa .

SOLUTION

$$\phi = 3^\circ = 52.360 \times 10^{-3} \text{ rad}, \quad T = 9 \times 10^3 \text{ N}\cdot\text{m} \quad L = 2.0 \text{ m}$$

$$\phi = \frac{TL}{GJ} = \frac{2TL}{\pi C^4 G} \quad \therefore C^4 = \frac{2TL}{\pi G \phi} \quad \text{based on twist angle}$$

$$\tau = \frac{Tc}{J} = \frac{2T}{\pi C^3} \quad \therefore C^3 = \frac{2T}{\pi \tau} \quad \text{based shearing stress}$$

(a) Steel shaft: $\tau = 90 \times 10^6 \text{ Pa}, \quad G = 77 \times 10^9 \text{ Pa}$

Based on twist angle $C^4 = \frac{(2)(9 \times 10^3)(2.0)}{\pi(77 \times 10^9)(52.360 \times 10^{-3})} = 2.842 \times 10^{-6} \text{ m}^4$

$$C = 41.06 \times 10^{-3} \text{ m} = 41.06 \text{ mm} \quad d = 2C = 82.1 \text{ mm}$$

Based on shearing stress $C^3 = \frac{(2)(9 \times 10^3)}{\pi(90 \times 10^6)} = 63.662 \times 10^{-6} \text{ m}^3$

$$C = 39.93 \times 10^{-3} \text{ m} = 39.93 \text{ mm} \quad d = 2C = 79.9 \text{ mm}$$

Required value of d is the larger: $d = 82.1 \text{ mm}$ ▶

(b) Bronze shaft: $\tau = 35 \times 10^6 \text{ Pa}, \quad G = 42 \times 10^9 \text{ Pa}$

Based on twist angle $C^4 = \frac{(2)(9 \times 10^3)(2.0)}{\pi(42 \times 10^9)(52.360 \times 10^{-3})} = 5.2103 \times 10^{-6} \text{ m}^4$

$$C = 47.78 \times 10^{-3} \text{ m} = 47.78 \text{ mm} \quad d = 2C = 95.6 \text{ mm}$$

Based on shearing stress $C^3 = \frac{(2)(9 \times 10^3)}{\pi(35 \times 10^6)} = 163.702 \times 10^{-6} \text{ m}^3$

$$C = 54.70 \times 10^{-3} \text{ m} = 54.70 \text{ mm} \quad d = 2C = 109.4 \text{ mm}$$

Required value of d is the larger $d = 109.4 \text{ mm}$ ▶

PROBLEM 3.46

3.46 The design specifications of a 4-ft-long solid circular transmission shaft require that the angle of twist of the shaft not exceed 4° when a torque of 6 kip·in. is applied. Determine the required diameter of the shaft, knowing that the shaft is made of a steel with an allowable shearing stress of 12 ksi and a modulus of rigidity of 11.2×10^6 psi.

SOLUTION

Based on twist angle $\phi = 4^\circ = 69.81 \times 10^{-3}$ rad. $L = 4 \text{ ft} = 48 \text{ in.}$

$$T = 6 \text{ kip}\cdot\text{in} = 6000 \text{ lb}\cdot\text{in.}, \quad G = 11.2 \times 10^6 \text{ psi}$$

$$\phi = \frac{TL}{GJ} = \frac{2TL}{\pi Gc^4} \quad c^4 = \frac{2TL}{\pi G\phi} = \frac{(2)(6000)(48)}{\pi(11.2 \times 10^6)(69.81 \times 10^{-3})} = 0.2345 \text{ in}^4$$

$$c = 0.696 \text{ in} \quad d = 2c = 1.392 \text{ in.}$$

Based on shearing stress $\tau = 12 \text{ ksi} = 12000 \text{ psi}$

$$\tau = \frac{Tc}{J} = \frac{2T}{\pi c^3} \quad c^3 = \frac{2T}{\pi\tau} = \frac{(2)(6000)}{\pi(12000)} = 0.3183 \text{ in}^3$$

$$c = 0.683 \text{ in} \quad d = 2c = 1.366 \text{ in.}$$

Required diameter is the larger $d = 1.392 \text{ in.}$ ◀

Www.iepnu.ir



PROBLEM 3.47

3.47 The design of the gear-and-shaft system shown requires that steel shafts of the same diameter be used for both AB and CD. It is further required that $\tau_{\max} < 60 \text{ MPa}$ and that the angle ϕ_D through which end D of shaft CD rotates not exceed 1.5° . Knowing that $G = 77 \text{ GPa}$, determine the required diameter of the shafts.

SOLUTION

$$T_{CB} = T_D = 1000 \text{ N}\cdot\text{m}$$

$$T_{AB} = \frac{r_B}{r_C} T_{CB} = \frac{100}{40} (1000) = 2500 \text{ N}\cdot\text{m}$$

For design based on stress, use larger torque $T_{AB} = 2500 \text{ N}\cdot\text{m}$

$$\gamma = \frac{TC}{J} = \frac{2T}{\pi C^3}$$

$$C^3 = \frac{2T}{\pi \gamma} = \frac{(2)(2500)}{\pi (60 \times 10^6)} = 26.526 \times 10^{-6} \text{ m}^3$$

$$C = 29.82 \times 10^{-3} \text{ m} = 29.82 \text{ mm}, \quad d = 2C = 59.6 \text{ mm}$$

Design based on rotation angle $\phi_D = 1.5^\circ = 26.18 \times 10^{-3} \text{ rad}$

Shaft AB: $T_{AB} = 2500 \text{ N}\cdot\text{m}$, $L = 0.4 \text{ m}$

$$\phi_{AB} = \frac{TL}{GJ} = \frac{(2500)(0.4)}{GJ} = \frac{1000}{GJ}$$

Gears $\left\{ \begin{array}{l} \phi_B = \phi_{AB} = \frac{1000}{GJ} \\ \phi_C = \frac{r_B}{r_C} \phi_B = \frac{100}{40} \cdot \frac{1000}{GJ} = \frac{2500}{GJ} \end{array} \right.$

Shaft CD $T_{CD} = 1000 \text{ N}\cdot\text{m}$, $L = 0.6 \text{ m}$

$$\phi_{CD} = \frac{TL}{GJ} = \frac{(1000)(0.6)}{GJ} = \frac{600}{GJ}$$

$$\phi_D = \phi_C + \phi_{CD} = \frac{2500}{GJ} + \frac{600}{GJ} = \frac{3100}{GJ} = \frac{3100}{G \frac{\pi}{2} C^4}$$

$$C^4 = \frac{(2)(3100)}{\pi G \phi_D} = \frac{(2)(3100)}{\pi (77 \times 10^9) (26.18 \times 10^{-3})} = 979.06 \times 10^{-9} \text{ m}^4$$

$$C = 31.46 \times 10^{-3} \text{ m} = 31.46 \text{ mm}, \quad d = 2C = 62.9 \text{ mm}$$

Design must use larger value for d

$$d = 62.9 \text{ mm}$$

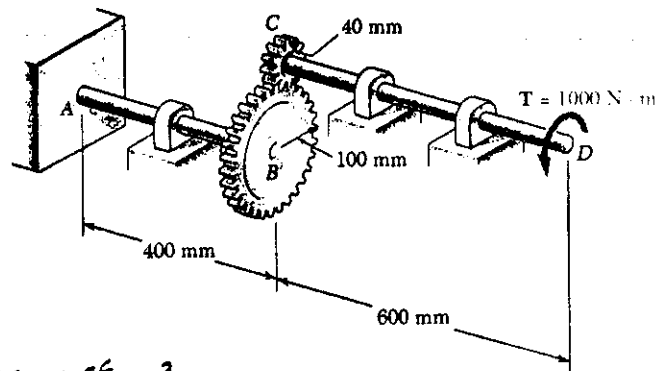

PROBLEM 3.48

3.48 The electric motor exerts a torque of 800 N·m on the steel shaft *ABCD* when it is rotating at constant speed. Design specifications require that the diameter of the shaft be uniform from *A* to *D* and that the angle of twist between *A* and *D* not exceed 1.5°. Knowing that $\tau_{\max} \leq 60$ MPa and $G = 77$ GPa, determine the minimum diameter shaft that may be used.

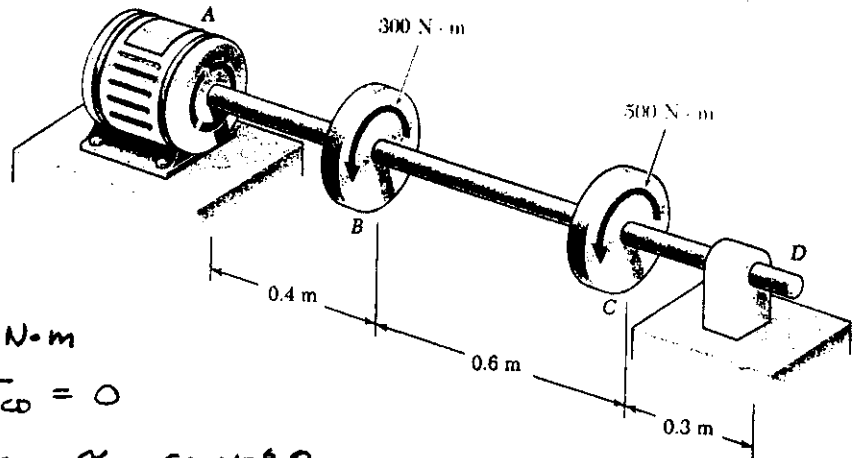

SOLUTION

Torques

$$T_{AB} = 300 + 500 = 800 \text{ N}\cdot\text{m}$$

$$T_{BC} = 500 \text{ N}\cdot\text{m}, \quad T_{CD} = 0$$

Design based on stress $\tau = 60 \times 10^6 \text{ Pa}$

$$\tau = \frac{Tc}{J} = \frac{2T}{\pi c^3} \quad c^3 = \frac{2T}{\pi \tau} = \frac{(2)(800)}{\pi(60 \times 10^6)} = 8.488 \times 10^{-6} \text{ m}^3$$

$$c = 20.40 \times 10^{-3} \text{ m} = 20.40 \text{ mm}, \quad d = 2c = 40.8 \text{ mm}$$

Design based on deformation $\phi_{D/A} = 1.5^\circ = 26.18 \times 10^{-3} \text{ rad}$

$$\phi_{D/C} = 0$$

$$\phi_{C/B} = \frac{T_{BC}L_{BC}}{GJ} = \frac{(500)(0.6)}{GJ} = \frac{600}{GJ}$$

$$\phi_{B/A} = \frac{T_{AB}L_{AB}}{GJ} = \frac{(800)(0.4)}{GJ} = \frac{320}{GJ}$$

$$\phi_{D/A} = \phi_{C/B} + \phi_{B/A} = \frac{620}{GJ} = \frac{620}{G \frac{\pi}{2} c^4} = \frac{(2)(620)}{\pi G c^4}$$

$$c^4 = \frac{(2)(620)}{\pi G \phi_{D/A}} = \frac{(2)(620)}{\pi(77 \times 10^9)(26.18 \times 10^{-3})} = 195.80 \times 10^{-9} \text{ m}^4$$

$$c = 21.04 \times 10^{-3} \text{ m} = 21.04 \text{ mm}, \quad d = 2c = 42.1 \text{ mm}$$

Design must use larger value of *d*

$$d = 42.1 \text{ mm}$$

PROBLEM 3.49

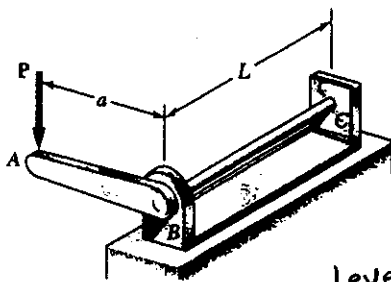

3.49 The solid cylindrical rod BC is attached to the rigid lever AB and to the fixed support at C . The vertical force P applied at A causes a small displacement Δ at point A . Show that the corresponding maximum shearing stress in the rod is

$$\tau = \frac{Gd}{2La} \Delta$$

where d is the diameter of the rod and G its modulus of rigidity.

SOLUTION

Lever AB turns through angle ϕ to position $A'B$ as shown in the auxiliary figure.

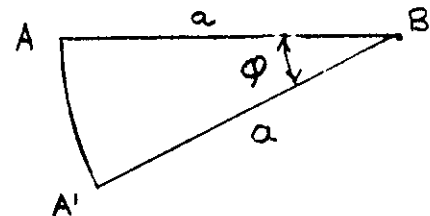

Vertical displacement is $\Delta = a \sin \phi$
 from which $\phi = \arcsin \frac{\Delta}{a}$

The maximum shearing stress in rod BC is

$$\tau_{\max} = G\gamma_{\max} = G \frac{C\phi}{L} = G \frac{d\phi}{2L} = \frac{Gd}{2L} \arcsin \frac{\Delta}{a}$$

For small $\frac{\Delta}{a}$, $\arcsin \frac{\Delta}{a} \approx \frac{\Delta}{a}$

$$\tau_{\max} = \frac{Gd\Delta}{2La}$$

PROBLEM 3.50

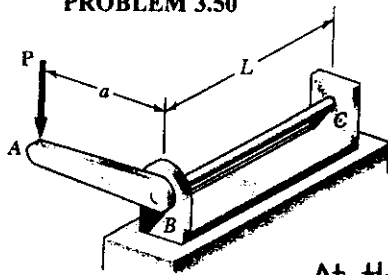

3.50 and 3.51 The solid cylindrical rod BC of length $L = 24$ in. is attached to the rigid lever AB of length $a = 15$ in. and to the support at C . When a 100-lb force P is applied at A , design specifications require that the displacement of A not exceed 1 in. when a 100-lb force P is applied at A . For the material indicated determine the required diameter of the rod.

3.50 Steel: $\tau_{all} = 15$ ksi, $G = 11.2 \times 10^6$ psi.

SOLUTION

At the allowable twist angle $\sin \phi = \frac{\Delta}{a} = \frac{1}{15} = 0.06667$
 $\phi = 3.8226^\circ = 0.066716$ rad.

$T = Pa \cos \phi = (100)(15) \cos 3.8226^\circ = 1496.7$ lb·in

Based on twist $\phi = \frac{TL}{GJ} = \frac{2TL}{\pi G C^4} \therefore C^4 = \frac{2TL}{\pi G \phi}$

$C^4 = \frac{(2)(1496.7)(24)}{\pi(11.2 \times 10^6)(0.066716)} = 30.603 \times 10^{-3} \text{ in}^4$ $C = 0.418$ in.

Based on stress $\tau = \frac{Tc}{J} = \frac{2T}{\pi C^3} \therefore C^3 = \frac{2T}{\pi \tau}$ ($\tau = 15000$ psi)

$C^3 = \frac{2(1496.7)}{\pi(15000)} = 63.522 \times 10^{-3} \text{ in}^3$ $C = 0.399$ in.

Use larger value for design $C = 0.399$ in $d = 2c = 0.837$ in. ◀

PROBLEM 3.51

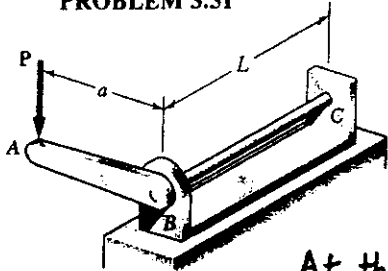

3.50 and 3.51 The solid cylindrical rod BC of length $L = 24$ in. is attached to the rigid lever AB of length $a = 15$ in. and to the support at C . When a 100-lb force P is applied at A , design specifications require that the displacement of A not exceed 1 in. when a 100-lb force P is applied at A . For the material indicated determine the required diameter of the rod.

3.51 Aluminum: $\tau_{all} = 10$ ksi, $G = 3.9 \times 10^6$ psi.

SOLUTION

At the allowable twist angle $\sin \phi = \frac{\Delta}{a} = \frac{1}{15} = 0.06667$
 $\phi = 3.8226^\circ = 0.066716$ rad.

$T = Pa \cos \phi = (100)(15) \cos 3.8226^\circ = 1496.7$ lb·in

Based on twist $\phi = \frac{TL}{GJ} = \frac{2TL}{\pi G C^4} \therefore C^4 = \frac{2TL}{\pi G \phi}$

$C^4 = \frac{(2)(1496.7)(24)}{\pi(3.9 \times 10^6)(0.066716)} = 87.888 \times 10^{-3} \text{ in}^4$ $C = 0.544$ in.

Based on stress $\tau = \frac{Tc}{J} = \frac{2T}{\pi C^3} \therefore C^3 = \frac{2T}{\pi \tau}$ ($\tau = 10000$ psi)

$C^3 = \frac{(2)(1496.7)}{\pi(10000)} = 95.283 \times 10^{-3} \text{ in}^3$ $C = 0.457$ in

Use larger value for design $C = 0.544$ in $d = 2c = 1.089$ in. ◀

PROBLEM 3.52

3.52 A 4-kN·m torque T is applied at end A of the composite shaft shown. Knowing that the modulus of rigidity is 77 GPa for the steel and 27 GPa for the aluminum, determine (a) the maximum shearing stress in the steel core, (b) the maximum shearing stress in the aluminum jacket, (c) the angle of twist at A .

SOLUTION

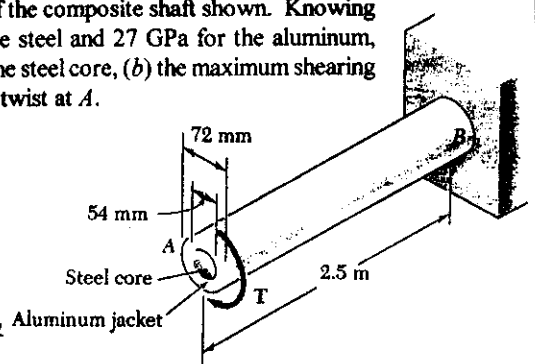

Steel core: $c_1 = \frac{1}{2} d_1 = 0.027 \text{ m}$

$$J_1 = \frac{\pi}{2} c_1^4 = \frac{\pi}{2} (0.027)^4 = 834.79 \times 10^{-9}$$

$$G_1 J_1 = (77 \times 10^9)(834.79 \times 10^{-9}) = 64.28 \times 10^3 \text{ N}\cdot\text{m}^2$$

Torque carried by steel core $T_1 = G_1 J_1 \phi / L$

Aluminum jacket: $c_1 = \frac{1}{2} d_1 = 0.027 \text{ m}$, $c_2 = \frac{1}{2} d_2 = 0.036 \text{ m}$

$$J_2 = \frac{\pi}{2} (c_2^4 - c_1^4) = \frac{\pi}{2} (0.036^4 - 0.027^4) = 1.80355 \times 10^{-6} \text{ m}^4$$

$$G_2 J_2 = (27 \times 10^9)(1.80355 \times 10^{-6}) = 48.70 \times 10^3 \text{ N}\cdot\text{m}^2$$

Torque carried by aluminum jacket $T_2 = G_2 J_2 \phi / L$

Total torque $T = T_1 + T_2 = (G_1 J_1 + G_2 J_2) \phi / L$

$$\frac{\phi}{L} = \frac{T}{G_1 J_1 + G_2 J_2} = \frac{4 \times 10^3}{64.28 \times 10^3 + 48.70 \times 10^3} = 35.406 \times 10^{-3} \text{ rad/m}$$

(a) Maximum shearing stress in steel core

$$\tau = G_1 \gamma = G_1 c_1 \frac{\phi}{L} = (77 \times 10^9)(0.027)(35.406 \times 10^{-3})$$

$$= 73.6 \times 10^6 \text{ Pa}$$

$$73.6 \text{ MPa}$$

(b) Maximum shearing stress in aluminum jacket

$$\tau = G_2 \gamma = G_2 c_2 \frac{\phi}{L} = (27 \times 10^9)(0.036)(35.406 \times 10^{-3})$$

$$= 34.4 \times 10^6 \text{ Pa}$$

$$34.4 \text{ MPa}$$

(c) Angle of twist

$$\phi = L \frac{\phi}{L} = (2.5)(35.406 \times 10^{-3}) = 88.5 \times 10^{-3} \text{ rad}$$

$$= 5.07^\circ$$

PROBLEM 3.53

3.53 The composite shaft shown is to be twisted by applying a torque T at end A . Knowing that the modulus of rigidity is 77 GPa for the steel and 27 GPa for the aluminum, determine the largest angle through which end A may be rotated if the following allowable stresses are not to be exceeded $\tau_{\text{steel}} = 60 \text{ MPa}$ and $\tau_{\text{aluminum}} = 45 \text{ MPa}$.

SOLUTION

$$\tau_{\text{max}} = G \gamma_{\text{max}} = G C_{\text{max}} \frac{\phi}{L}$$

$$\frac{\phi_{\text{all}}}{L} = \frac{\tau_{\text{all}}}{G C_{\text{max}}} \quad \text{for each material}$$

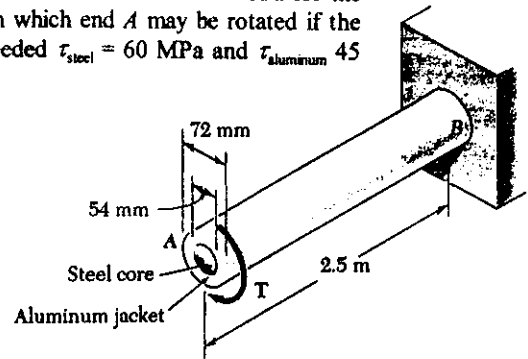

Steel core: $\tau_{\text{all}} = 60 \times 10^6 \text{ Pa}$, $C_{\text{max}} = \frac{1}{2}d = 0.027 \text{ m}$, $G = 77 \times 10^9 \text{ Pa}$

$$\frac{\phi_{\text{all}}}{L} = \frac{60 \times 10^6}{(77 \times 10^9)(0.027)} = 28.860 \times 10^{-3} \text{ rad/m}$$

Aluminum jacket: $\tau_{\text{all}} = 45 \times 10^6 \text{ Pa}$, $C_{\text{max}} = \frac{1}{2}d = 0.036 \text{ m}$, $G = 27 \times 10^9 \text{ Pa}$

$$\frac{\phi_{\text{all}}}{L} = \frac{45 \times 10^6}{(27 \times 10^9)(0.036)} = 46.296 \times 10^{-3} \text{ rad/m}$$

Smaller value governs

$$\frac{\phi_{\text{all}}}{L} = 28.860 \times 10^{-3} \text{ rad/m}$$

Allowable angle of twist

$$\begin{aligned} \phi_{\text{all}} &= L \frac{\phi_{\text{all}}}{L} = (2.5)(28.860 \times 10^{-3}) \\ &= 72.15 \times 10^{-3} \text{ rad} = 4.13^\circ \end{aligned}$$

www.iepnu.ir



PROBLEM 3.54

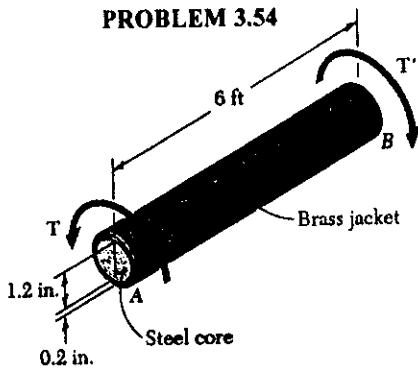

3.54 The composite shaft shown consists of a 0.2-in.-thick brass jacket ($G = 5.6 \times 10^6$ psi) bonded to a 1.2-in.-diameter steel core ($G = 11.2 \times 10^6$ psi). Knowing that the shaft is subjected to 5-kip-in. torques, determine (a) the maximum shearing stress in the brass jacket, (b) the maximum shearing stress in the steel core, (c) the angle of twist of end B relative to end A.

SOLUTION

Steel core: $c_1 = \frac{1}{2}d = 0.6$ in

$$J_1 = \frac{\pi}{2}c_1^4 = \frac{\pi}{2}(0.6)^4 = 0.203575 \text{ in}^4$$

$$G_1J_1 = (11.2 \times 10^6)(0.203575) = 2.2800 \times 10^6 \text{ lb}\cdot\text{in}^2$$

Torque carried by steel core $T_1 = G_1J_1 \frac{\phi}{L}$

Brass jacket: $c_2 = c_1 + t = 0.6 + 0.2 = 0.8$ in

$$J_2 = \frac{\pi}{2}(c_2^4 - c_1^4) = \frac{\pi}{2}(0.8^4 - 0.6^4) = 0.439823 \text{ in}^4$$

$$G_2J_2 = (5.6 \times 10^6)(0.439823) = 2.4630 \times 10^6 \text{ lb}\cdot\text{in}^2$$

Torque carried by brass jacket $T_2 = G_2J_2 \frac{\phi}{L}$

Total torque $T = T_1 + T_2 = (G_1J_1 + G_2J_2) \frac{\phi}{L}$

$$\frac{\phi}{L} = \frac{T}{G_1J_1 + G_2J_2} = \frac{5 \times 10^3}{2.2800 \times 10^6 + 2.4630 \times 10^6} = 1.0542 \times 10^{-3} \text{ rad/in}$$

(a) Maximum shearing stress in brass jacket

$$\tau_{\max} = G_2 \gamma_{\max} = G_2 c_2 \frac{\phi}{L} = (5.6 \times 10^6)(0.8)(1.0542 \times 10^{-3})$$

$$= 4.72 \times 10^3 \text{ psi}$$

$$4.72 \text{ ksi} \quad \blacktriangleleft$$

(b) Maximum shearing stress in steel core

$$\tau_{\max} = G_1 \gamma_{\max} = G_1 c_1 \frac{\phi}{L} = (11.2 \times 10^6)(0.6)(1.0542 \times 10^{-3})$$

$$= 7.08 \times 10^3 \text{ psi}$$

$$7.08 \text{ ksi} \quad \blacktriangleleft$$

(c) Angle of twist

$$(L = 6\text{ft} = 72 \text{ in})$$

$$\phi = L \frac{\phi}{L} = (72)(1.0542 \times 10^{-3}) = 75.9 \times 10^{-3} \text{ rad}$$

$$= 4.35^\circ \quad \blacktriangleleft$$

PROBLEM 3.55

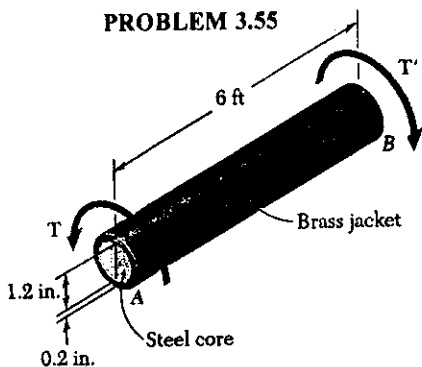

3.55 The composite shaft shown is to be twisted by applying the torques shown. Knowing that the modulus of rigidity is 11.2×10^6 psi for the steel and 5.6×10^6 psi for the brass, determine the largest angle of twist of end B relative to end A if the following allowable stresses are not to be exceeded $\tau_{\text{steel}} = 15$ ksi and $\tau_{\text{brass}} = 8$ ksi.

SOLUTION

$$\tau_{\text{max}} = G \gamma_{\text{max}} = G C_{\text{max}} \frac{\phi}{L}$$

$$\frac{\phi_{\text{all}}}{L} = \frac{\tau_{\text{all}}}{G C_{\text{max}}} \quad \text{for each material}$$

Steel core: $\tau_{\text{all}} = 15 \text{ ksi} = 15000 \text{ psi}$, $C_{\text{max}} = \frac{1}{2}d = 0.6 \text{ in}$

$$\frac{\phi_{\text{all}}}{L} = \frac{15000}{(11.2 \times 10^6)(0.6)} = 2.2321 \times 10^{-3} \text{ rad/in.}$$

Brass jacket: $\tau_{\text{all}} = 8 \text{ ksi} = 8000 \text{ psi}$, $C_{\text{max}} = 0.6 + 0.2 = 0.8 \text{ in}$

$$\frac{\phi_{\text{all}}}{L} = \frac{8000}{(5.6 \times 10^6)(0.8)} = 1.7857 \times 10^{-3} \text{ rad/in.}$$

Smaller value governs $\frac{\phi_{\text{all}}}{L} = 1.7857 \times 10^{-3} \text{ rad/in.}$

Allowable angle of twist

$$L = 6 \text{ ft} = 72 \text{ in}$$

$$\begin{aligned} \phi_{\text{all}} &= L \frac{\phi_{\text{all}}}{L} = (72)(1.7857 \times 10^{-3}) = 128.57 \times 10^{-3} \text{ rad} \\ &= 7.37^\circ \end{aligned}$$

PROBLEM 3.56

3.56 Two solid steel shafts are fitted with flanges which are then connected by fitted bolts so that there is no relative rotation between the flanges. Knowing that $G = 77$ GPa, determine the maximum shearing stress in each shaft when a 500 N·m torque is applied to flange B.

SOLUTION

Shaft AB

$$T = T_{AB}, L_{AB} = 0.6 \text{ m}, c = \frac{1}{2}d = 0.015 \text{ m}$$

$$J_{AB} = \frac{\pi}{2}c^4 = \frac{\pi}{2}(0.015)^4 = 79.52 \times 10^{-9} \text{ m}^4$$

$$\phi_B = \frac{T_{AB} L_{AB}}{G_{AB} J_{AB}}$$

$$T_{AB} = \frac{G_{AB} J_{AB}}{L_{AB}} \phi_B = \frac{(77 \times 10^9)(79.52 \times 10^{-9})}{0.6} \phi_B$$

$$= 10.205 \times 10^3 \phi_B$$

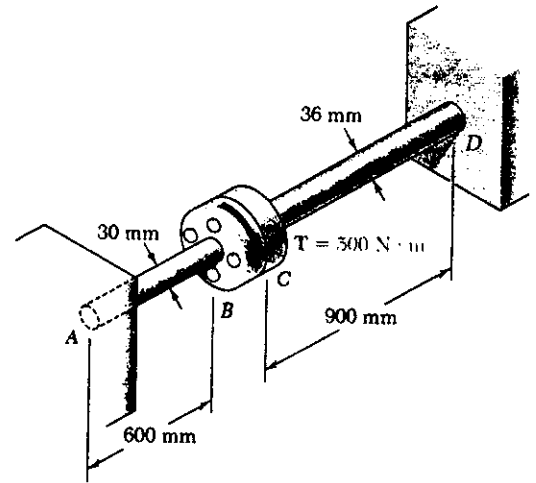

Shaft CD

$$T = T_{CD}, L_{CD} = 0.9 \text{ m}, c = \frac{1}{2}d = 0.018 \text{ m}, J_{CD} = \frac{\pi}{2}c^4 = \frac{\pi}{2}(0.018)^4$$

$$J_{CD} = 164.896 \times 10^{-9} \text{ m}^4$$

$$T_{CD} = \frac{G_{CD} J_{CD}}{L_{CD}} \phi_C = \frac{(77 \times 10^9)(164.896 \times 10^{-9})}{0.9} \phi_C = 14.108 \times 10^3 \phi_C$$

Matching rotation at the flanges $\phi_B = \phi_C = \phi$

Total torque on flanges $T = T_{AB} + T_{CD} = 500 \text{ N}\cdot\text{m}$

$$500 = (10.205 \times 10^3 + 14.108 \times 10^3) \phi \quad \therefore \phi = 20.565 \times 10^{-3} \text{ rad}$$

$$T_{AB} = (10.205 \times 10^3)(20.565 \times 10^{-3}) = 209.87 \text{ N}\cdot\text{m}$$

$$T_{CD} = (14.108 \times 10^3)(20.565 \times 10^{-3}) = 290.13 \text{ N}\cdot\text{m}$$

Maximum shearing stress in AB

$$\tau_{AB} = \frac{T_{AB} c}{J_{AB}} = \frac{(209.87)(0.015)}{79.52 \times 10^{-9}} = 39.59 \times 10^6 \text{ Pa} \quad 39.6 \text{ MPa} \quad \blacktriangleleft$$

Maximum shearing stress in CD

$$\tau_{CD} = \frac{T_{CD} c}{J_{CD}} = \frac{(290.13)(0.018)}{164.896 \times 10^{-9}} = 31.67 \times 10^6 \text{ Pa} \quad 31.7 \text{ MPa} \quad \blacktriangleleft$$

PROBLEM 3.57

3.57 and 3.58 Two solid steel shafts are fitted with flanges which are then connected by bolts as shown. The bolts are slightly undersized and permit a 1.5° rotation of one flange with respect to the other before the flanges begin to rotate as a single unit. Knowing that $G = 77 \text{ GPa}$, determine the maximum shearing stress in each shaft when a $500 \text{ N}\cdot\text{m}$ torque T is applied to the flange indicated.

3.57 The torque T is applied to flange B .

SOLUTION

Shaft AB

$$T = T_{AB}, \quad L = 0.6 \text{ m}, \quad c = \frac{1}{2}d = 0.015 \text{ m}$$

$$J_{AB} = \frac{\pi}{2}c^4 = \frac{\pi}{2}(0.015)^4 = 79.52 \times 10^{-9} \text{ m}^4$$

$$\phi_B = \frac{T_{AB} L_{AB}}{G_{AB} J_{AB}}$$

$$T_{AB} = \frac{G_{AB} J_{AB}}{L} \phi_B = \frac{(77 \times 10^9)(79.52 \times 10^{-9})}{0.6} \phi_B$$

$$= 10.205 \times 10^3 \phi_B$$

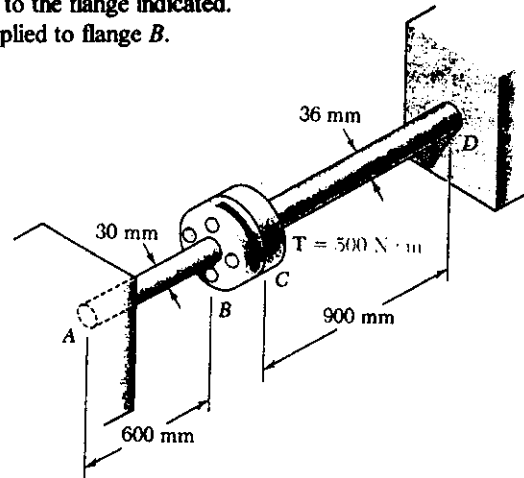

Shaft CD

$$T = T_{CD}, \quad L_{CD} = 0.9 \text{ m}, \quad c = \frac{1}{2}d = 0.018 \text{ m}, \quad J_{CD} = \frac{\pi}{2}c^4 = \frac{\pi}{2}(0.018)^4$$

$$J_{CD} = 164.896 \times 10^{-9} \text{ m}^4$$

$$T_{CD} = \frac{G_{CD} J_{CD}}{L_{CD}} \phi_C = \frac{(77 \times 10^9)(164.896 \times 10^{-9})}{0.9} \phi_C = 14.108 \times 10^3 \phi_C$$

Clearance rotation for flange B $\phi_B' = 1.5^\circ = 26.18 \times 10^{-3} \text{ rad}$

Torque to remove clearance: $T_{AB}' = (10.205 \times 10^3)(26.18 \times 10^{-3}) = 267.17 \text{ N}\cdot\text{m}$

Torque T'' to cause additional rotation ϕ'' : $T'' = 500 - 267.17 = 232.83 \text{ N}\cdot\text{m}$

$$T'' = T_{AB}'' + T_{CD}''$$

$$232.83 = (10.205 \times 10^3 + 14.108 \times 10^3) \phi'' \quad \therefore \quad \phi'' = 9.5765 \times 10^{-3} \text{ rad}$$

$$T_{AB}'' = (10.205 \times 10^3)(9.5765 \times 10^{-3}) = 97.73 \text{ N}\cdot\text{m}$$

$$T_{CD}'' = (14.108 \times 10^3)(9.5765 \times 10^{-3}) = 135.10 \text{ N}\cdot\text{m}$$

Maximum shearing stress in AB

$$\tau_{AB} = \frac{T_{AB} c}{J_{AB}} = \frac{(267.17 + 97.73)(0.015)}{79.52 \times 10^{-9}} = 68.8 \times 10^6 \text{ Pa} \quad 68.8 \text{ MPa} \quad \blacktriangleleft$$

Maximum shearing stress in CD

$$\tau_{CD} = \frac{T_{CD} c}{J_{CD}} = \frac{(135.10)(0.018)}{164.896 \times 10^{-9}} = 14.75 \times 10^6 \text{ Pa} \quad 14.75 \text{ MPa} \quad \blacktriangleleft$$

PROBLEM 3.58

3.57 and 3.58 Two solid steel shafts are fitted with flanges which are then connected by bolts as shown. The bolts are slightly undersized and permit a 1.5° rotation of one flange with respect to the other before the flanges begin to rotate as a single unit. Knowing that $G = 77 \text{ GPa}$, determine the maximum shearing stress in each shaft when a $500 \text{ N}\cdot\text{m}$ torque T is applied to the flange indicated.

3.58 The torque T is applied to flange C.

SOLUTION

Shaft AB

$$T = T_{AB}, L_{AB} = 0.6 \text{ m}, c = \frac{1}{2}d = 0.015 \text{ m}$$

$$J_{AB} = \frac{\pi}{2}c^4 = \frac{\pi}{2}(0.015)^4 = 79.52 \times 10^{-9} \text{ m}^4$$

$$\phi_B = \frac{T_{AB} L_{AB}}{G_{AB} J_{AB}}$$

$$T_{AB} = \frac{G_{AB} J_{AB}}{L_{AB}} \phi_B = \frac{(77 \times 10^9)(79.52 \times 10^{-9})}{0.6} \phi_B$$

$$= 10.205 \times 10^3 \phi_B$$

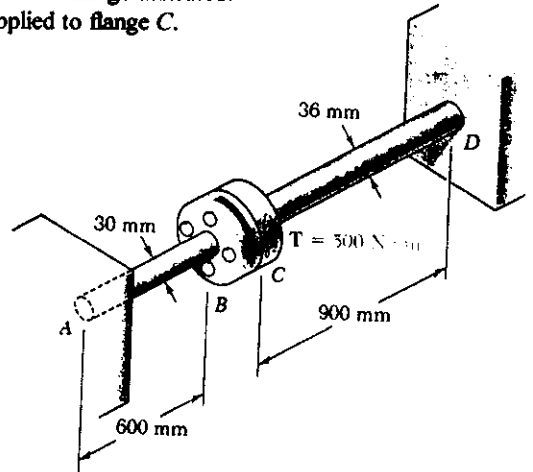

Shaft CD

$$T = T_{CD}, L_{CD} = 0.9 \text{ m}, c = \frac{1}{2}d = 0.018 \text{ m}, J_{CD} = \frac{\pi}{2}c^4 = \frac{\pi}{2}(0.018)^4$$

$$J_{CD} = 164.896 \times 10^{-9} \text{ m}^4$$

$$T_{CD} = \frac{G_{CD} J_{CD}}{L_{CD}} \phi_C = \frac{(77 \times 10^9)(164.896 \times 10^{-9})}{0.9} \phi_C = 14.108 \times 10^3 \phi_C$$

Clearance rotation for flange C $\phi_C' = 1.5^\circ = 26.18 \times 10^{-3} \text{ rad}$

Torque to remove clearance: $T_{CD}' = (14.108 \times 10^3)(26.18 \times 10^{-3}) = 369.35 \text{ N}\cdot\text{m}$

Torque T'' to cause additional rotation ϕ'' : $T'' = 500 - 369.35 = 130.65 \text{ N}\cdot\text{m}$

$$T'' = T_{AB}'' + T_{CD}''$$

$$130.65 = (10.205 \times 10^3 + 14.108 \times 10^3) \phi'' \quad \phi'' = 5.3737 \times 10^{-3} \text{ rad}$$

$$T_{AB}'' = (10.205 \times 10^3)(5.3737 \times 10^{-3}) = 54.84 \text{ N}\cdot\text{m}$$

$$T_{CD}'' = (14.108 \times 10^3)(5.3737 \times 10^{-3}) = 75.81 \text{ N}\cdot\text{m}$$

Maximum shearing stress in AB

$$\tau_{AB} = \frac{T_{AB} c}{J_{AB}} = \frac{(54.84)(0.015)}{79.52 \times 10^{-9}} = 10.34 \times 10^6 \text{ Pa} = 10.34 \text{ MPa}$$

Maximum shearing stress in CD

$$\tau_{CD} = \frac{T_{CD} c}{J_{CD}} = \frac{(369.35 + 75.81)(0.018)}{164.896 \times 10^{-9}} = 48.6 \times 10^6 \text{ Pa} = 48.6 \text{ MPa}$$

PROBLEM 3.59

3.59 At a time when rotation is prevented at the lower end of each shaft, a 50-N·m torque is applied to end A of shaft AB. Knowing that $G = 77 \text{ GPa}$ for both shafts, determine (a) the maximum shearing stress in shaft CD, (b) the angle of rotation at A.

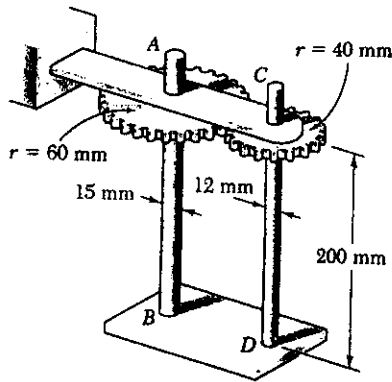

SOLUTION

Let $T_A =$ torque applied at A = 50 N·m

$T_{AB} =$ torque in shaft AB

$T_{CD} =$ torque in shaft CD

Statics

$$T_A - T_{AB} - Fr_A = 0$$

$$T_{CD} - Fr_c = 0$$

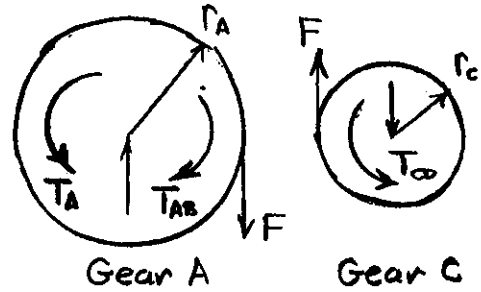

$$T_{CD} = \frac{r_c}{r_A} (T_A - T_{AB}) = \frac{2}{3} (T_A - T_{AB})$$

Kinematics: $r_A \phi_A = r_c \phi_c$ $\phi_A = \frac{r_c}{r_A} \phi_c = \frac{2}{3} \phi_c$

Angles of twist $\phi_A = \frac{T_{AB} L}{G J_{AB}}$ $\phi_c = \frac{T_{CD} L}{G J_{CD}} = \frac{2}{3} \frac{(T_A - T_{AB}) L}{G J_{CD}}$

$$\frac{T_{AB} L}{G J_{AB}} = \frac{2}{3} \cdot \frac{2}{3} \frac{(T_A - T_{AB}) L}{G J_{CD}}$$

$$\left(\frac{4}{9} + \frac{J_{CD}}{J_{AB}} \right) T_{AB} = \left(\frac{4}{9} + \left(\frac{12}{15} \right)^4 \right) T_{AB} = \frac{4}{9} T_A$$

$$T_{AB} = 0.5204 T_A = (0.5204)(50) = 26.02 \text{ N·m}$$

$$T_{CD} = \frac{2}{3} (50 - 26.02) = 15.99 \text{ N·m}$$

(a) Maximum shearing stress in shaft CD

$$\tau_{CD} = \frac{T_{CD} c}{J_{CD}} = \frac{2 T_{CD}}{\pi c^3} = \frac{(2)(15.99)}{\pi (0.006)^3} = 47.1 \times 10^6 \text{ Pa} = 47.1 \text{ MPa} \blacktriangleleft$$

(b) Angle of rotation at A

$$\phi_A = \frac{T_{AB} L}{G J_{AB}} = \frac{2 T_{AB} L}{\pi G C_{AB}^4} = \frac{(2)(26.02)(0.200)}{\pi (77 \times 10^9)(0.0075)^4} = 13.598 \times 10^{-3} \text{ rad} \\ = 0.779^\circ \blacktriangleleft$$

PROBLEM 3.60

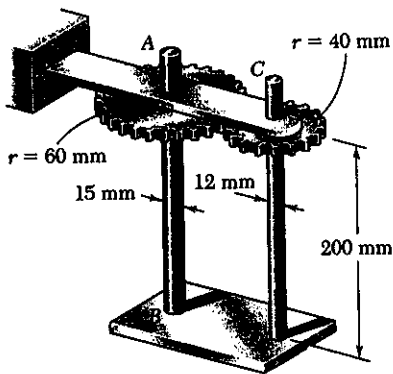

3.59 At a time when rotation is prevented at the lower end of each shaft, a 50-N·m torque is applied to end A of shaft AB. Knowing that $G = 77 \text{ GPa}$ for both shafts, determine (a) the maximum shearing stress in shaft CD, (b) the angle of rotation at A.
 3.60 Solve Prob. 3.59, assuming that the 50-N·m torque is applied to end C of shaft CD.

SOLUTION

Let $T_c =$ torque applied at C = 50 N·m
 $T_{CD} =$ torque in shaft CD
 $T_{AB} =$ torque in shaft AB

Statics.

$$T_{AB} - r_A F = 0$$

$$T_c - T_{CD} - r_c F = 0$$

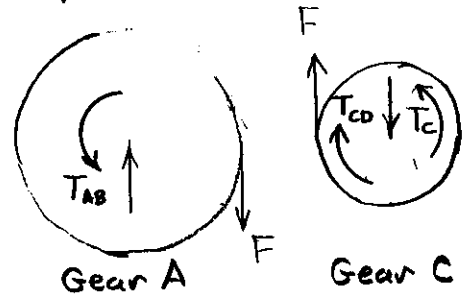

$$T_{AB} = \frac{r_A}{r_c} (T_c - T_{CD}) = \frac{3}{2} (T_c - T_{CD})$$

Kinematics: $r_A \phi_A = r_c \phi_c$ $\phi_c = \frac{r_A}{r_c} \phi_A = \frac{3}{2} \phi_A$

Angles of twist $\phi_c = \frac{T_{CD} L}{G J_{CD}}$ $\phi_A = \frac{T_{AB} L}{G J_{AB}} = \frac{3}{2} \frac{(T_c - T_{CD}) L}{G J_{AB}}$

$$\frac{T_{CD} L}{G J_{CD}} = \frac{3}{2} \cdot \frac{3}{2} \frac{T_c - T_{CD}}{G J_{AB}}$$

$$\left(\frac{J_{AB}}{J_{CD}} + \frac{9}{4} \right) T_{CD} = \left(\left(\frac{15}{12} \right)^4 + \frac{9}{4} \right) T_{CD} = \frac{9}{4} T_c$$

$$T_{CD} = 0.4796 T_c = (0.4796)(50) = 23.98 \text{ N}\cdot\text{m}$$

$$T_{AB} = \frac{3}{2} (50 - 23.98) = 39.03 \text{ N}\cdot\text{m}$$

(a) Maximum shearing stress in shaft CD

$$\tau_{CD} = \frac{T_{CD} c}{J} = \frac{2 T_{CD}}{\pi c^3} = \frac{(2)(23.98)}{\pi (0.006)^3} = 70.7 \times 10^6 \text{ Pa} = 70.7 \text{ MPa} \blacktriangleleft$$

(b) Angle of rotation at A

$$\phi_A = \frac{T_{AB} L}{G J_{AB}} = \frac{2 T_{AB} L}{\pi G c_{AB}^4} = \frac{(2)(39.03)(0.200)}{\pi (77 \times 10^9)(0.0075)^4} = 20.379 \times 10^{-3} \text{ rad} \\ = 1.169^\circ \blacktriangleleft$$

PROBLEM 3.61

3.61 The steel jacket *CD* has been attached to the 40-mm-diameter steel shaft *AE* by means of rigid flanges welded to the jacket and to the rod. The outer diameter of the jacket is 80 mm and its wall thickness is 4 mm. If 500-N·m torques are applied as shown, determine the maximum shearing stress in the jacket.

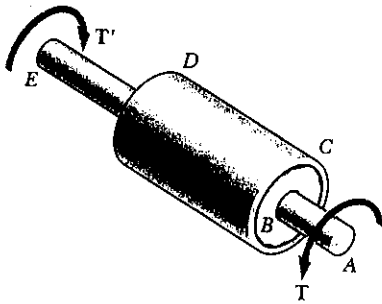

SOLUTION

Solid shaft: $c = \frac{1}{2}d = 0.020 \text{ m}$

$$J_s = \frac{\pi}{2}c^4 = \frac{\pi}{2}(0.020)^4 = 251.33 \times 10^{-9} \text{ m}^4$$

Jacket: $c_2 = \frac{1}{2}d = 0.040 \text{ m}$

$$c_1 = c_2 - t = 0.040 - 0.004 = 0.036 \text{ m}$$

$$J_J = \frac{\pi}{2}(c_2^4 - c_1^4) = \frac{\pi}{2}(0.040^4 - 0.036^4) = 1.3829 \times 10^{-6} \text{ m}^4$$

Torque carried by shaft $T_s = GJ_s \phi / L$

Torque carried by jacket $T_J = GJ_J \phi / L$

Total torque $T = T_s + T_J = (J_s + J_J)G \phi / L \therefore \frac{G\phi}{L} = \frac{T}{J_s + J_J}$

$$T_J = \frac{J_J}{J_s + J_J} T = \frac{(1.3829 \times 10^{-6})(500)}{1.3829 \times 10^{-6} + 251.33 \times 10^{-6}} = 423.1 \text{ N}\cdot\text{m}$$

Maximum shearing stress in jacket

$$\tau = \frac{T_J c}{J_J} = \frac{(423.1)(0.040)}{1.3829 \times 10^{-6}} = 12.24 \times 10^6 \text{ Pa} \quad 12.24 \text{ MPa} \blacktriangleleft$$

PROBLEM 3.62

3.62 The mass moment of inertia of a gear is to be determined experimentally by using a torsional pendulum consisting of a 6-ft steel wire. Knowing that $G = 11.2 \times 10^6$ psi, determine the diameter of the wire for which the torsional spring constant will be 4.27 lb·ft/rad.

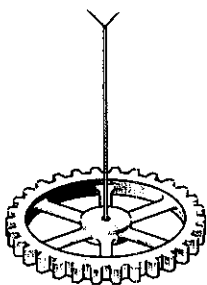

SOLUTION

Torsion spring constant $K = 4.27 \text{ lb}\cdot\text{ft}/\text{rad} = 51.24 \text{ lb}\cdot\text{in}/\text{rad}$

$$K = \frac{I}{\phi} = \frac{T}{TL/GJ} = \frac{GJ}{L} = \frac{\pi G c^4}{2L}$$

$$c^4 = \frac{2LK}{\pi G} = \frac{(2)(72)(51.24)}{\pi(11.2 \times 10^6)} = 209.7 \times 10^{-6} \text{ in}^4$$

$$c = 0.1203 \text{ in.} \quad d = 2c = 0.241 \text{ in.} \blacktriangleleft$$

PROBLEM 3.63

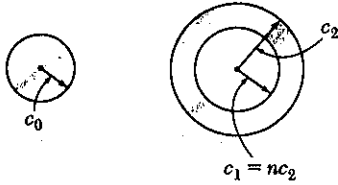

3.63 A solid shaft and a hollow shaft are made of the same material and are of the same weight and length. Denoting by n the ratio c_1/c_2 , show that the ratio T_s/T_h of the torque T_s in the solid shaft to the torque T_h in the hollow shaft is (a) $\sqrt{1-n^2}/(1+n^2)$ if the maximum shearing stress is the same in each shaft, (b) $(1-n^2)/(1+n^2)$ if the angle of twist is the same for each shaft.

SOLUTION

For equal weight and length, the areas are equal

$$\pi c_0^2 = \pi(c_2^2 - c_1^2) = \pi c_2^2(1 - n^2) \therefore c_0 = c_2 \sqrt{1 - n^2}$$

$$J_s = \frac{\pi}{2} c_0^4 = \frac{\pi}{2} c_2^4 (1 - n^2)^2 \quad J_h = \frac{\pi}{2} (c_2^4 - c_1^4) = \frac{\pi}{2} c_2^4 (1 - n^4)$$

(a) For equal stresses

$$\tau = \frac{T_s c_0}{J_s} = \frac{T_h c_2}{J_h}$$

$$\frac{T_s}{T_h} = \frac{J_s c_2}{J_h c_0} = \frac{\frac{\pi}{2} c_2^4 (1 - n^2)^2 c_2}{\frac{\pi}{2} c_2^4 (1 - n^4) c_2 \sqrt{1 - n^2}} = \frac{1 - n^2}{(1 + n^2) \sqrt{1 - n^2}} = \frac{\sqrt{1 - n^2}}{1 + n^2}$$

(b) For equal angles of twist

$$\phi = \frac{T_s L}{G J_s} = \frac{T_h L}{G J_h}$$

$$\frac{T_s}{T_h} = \frac{J_s}{J_h} = \frac{\frac{\pi}{2} c_2^4 (1 - n^2)^2}{\frac{\pi}{2} c_2^4 (1 - n^4)} = \frac{(1 - n^2)^2}{1 - n^4} = \frac{1 - n^2}{1 + n^2}$$

PROBLEM 3.64

3.64 A torque T is applied as shown to a solid tapered shaft AB . Show by integration that the angle of twist at A is

$$\phi = \frac{7TL}{12\pi Gc^4}$$

SOLUTION

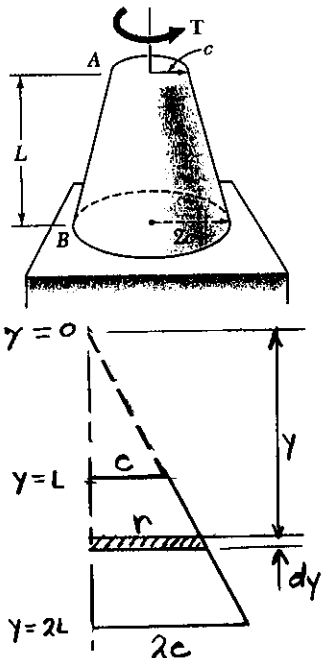

Introduce coordinate y as shown.

$$r = \frac{cy}{L}$$

Twist in length dy

$$d\phi = \frac{T dy}{GJ} = \frac{T dy}{G \frac{\pi}{2} r^4} = \frac{2TL^4 dy}{\pi Gc^4 y^4}$$

$$\begin{aligned} \phi &= \int_L^{2L} \frac{2TL^4}{\pi Gc^4} \frac{dy}{y^4} = \frac{2TL^4}{\pi Gc^4} \int_L^{2L} \frac{dy}{y^4} \\ &= \frac{2TL^4}{\pi Gc^4} \left\{ -\frac{1}{3y^3} \right\}_L^{2L} = \frac{2TL^4}{\pi Gc^4} \left\{ -\frac{1}{24L^3} + \frac{1}{3L^3} \right\} \\ &= \frac{2TL^4}{\pi Gc^4} \left\{ \frac{7}{24L^3} \right\} = \frac{7TL}{12\pi Gc^4} \end{aligned}$$

PROBLEM 3.65

3.65 An annular plate of thickness t and modulus of rigidity G is used to connect shaft AB of radius r_1 to tube CD of inner radius r_2 . Knowing that a torque T is applied to end A of shaft AB and that end D of tube CD is fixed, (a) determine the magnitude and location of the maximum shearing stress in the annular plate, (b) show that the angle through which end B of the shaft rotates with respect to end C of the tube is

SOLUTION

Use a free body consisting of shaft AB and an inner portion of the plate BC , the outer radius of this portion being ρ

$$\phi_{B/C} = \frac{T}{4\pi Gt} \left(\frac{1}{r_1^2} - \frac{1}{r_2^2} \right)$$

The force per unit length of circumference is τt .

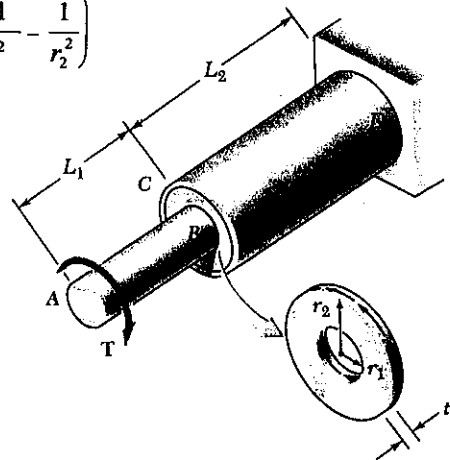
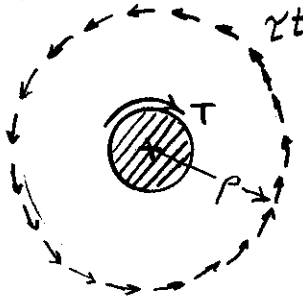

$$\Sigma M = 0$$

$$\tau t (2\pi\rho)\rho - T = 0$$

$$\tau = \frac{T}{2\pi t\rho^2}$$

(a) Maximum shearing stress occurs at $\rho = r_1$

$$\tau_{max} = \frac{T}{2\pi t r_1^2} \quad (1)$$

Shearing strain $\gamma = \frac{\tau}{G} = \frac{T}{2\pi G t \rho^2}$

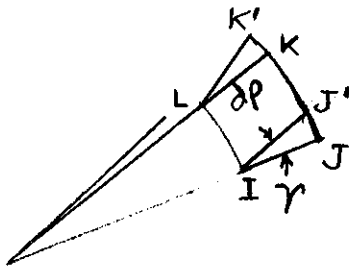

The relative circumferential displacement in radial length $d\rho$ is

$$ds = \gamma d\rho = \rho d\phi$$

$$d\phi = \gamma \frac{d\rho}{\rho}$$

$$d\phi = \frac{T}{2\pi G t \rho^2} \frac{d\rho}{\rho} = \frac{T}{2\pi G t} \frac{d\rho}{\rho^3}$$

$$\phi_{B/C} = \int_{r_1}^{r_2} \frac{T}{2\pi G t} \frac{d\rho}{\rho^3} = \frac{T}{2\pi G t} \int_{r_1}^{r_2} \frac{d\rho}{\rho^3} = \frac{T}{2\pi G t} \left\{ -\frac{1}{2\rho^2} \right\} \Big|_{r_1}^{r_2}$$

$$= \frac{T}{2\pi G t} \left\{ -\frac{1}{2r_2^2} + \frac{1}{2r_1^2} \right\} = \frac{T}{4\pi G t} \left\{ \frac{1}{r_1^2} - \frac{1}{r_2^2} \right\}$$

PROBLEM 3.66

3.66 An annular aluminum plate ($G = 27 \text{ GPa}$), of thickness $t = 6 \text{ mm}$, is used to connect the aluminum shaft AB , of length $L_1 = 90 \text{ mm}$ and radius $r_1 = 30 \text{ mm}$, to the aluminum tube CD , of length $L_2 = 150 \text{ mm}$, inner radius $r_2 = 75 \text{ mm}$ and 4 mm thickness. Knowing that a 2500-N·m torque T is applied to end A of shaft AB and that end D of tube CD is fixed, determine (a) the maximum shearing stress in the shaft-plate-tube system, (b) the angle through which end A rotates. (Hint: Use the formula derived in Prob. 3.65 to solve part b.)

SOLUTION

Shaft AB

$$\begin{aligned}\tau &= \frac{Tc}{J} = \frac{2T}{\pi c^3} = \frac{2T}{\pi r_1^3} \\ &= \frac{(2)(2500)}{\pi(0.030)^3} = 58.9 \times 10^6 \text{ Pa} \\ &= 58.9 \text{ MPa}\end{aligned}$$

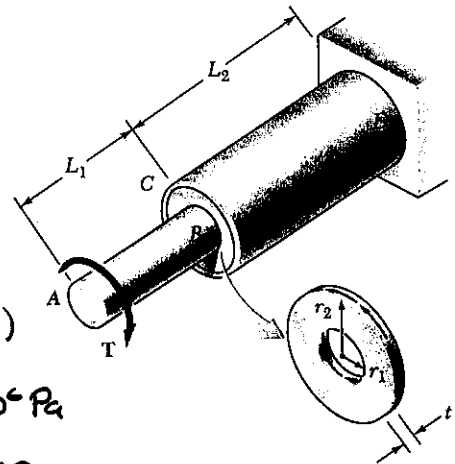

Plate BC (See PROBLEM 3.65 for derivation)

$$\begin{aligned}\tau &= \frac{T}{2\pi t r_1^2} = \frac{2500}{2\pi(0.006)(0.030)^2} = 73.7 \times 10^6 \text{ Pa} \\ &= 73.7 \text{ MPa}\end{aligned}$$

Shaft CD $c_1 = r_2 = 0.075 \text{ m}$, $c_2 = r_2 + t = 0.075 + 0.004 = 0.079 \text{ m}$

$$J = \frac{\pi}{2}(c_2^4 - c_1^4) = \frac{\pi}{2}(0.079^4 - 0.075^4) = 11.482 \times 10^{-6} \text{ m}^4$$

$$\tau = \frac{Tc_2}{J} = \frac{(2500)(0.079)}{11.482 \times 10^{-6}} = 17.20 \times 10^6 \text{ Pa} = 17.20 \text{ MPa}$$

(a) Largest stress

$$\tau = 73.7 \text{ MPa}$$

$$\begin{aligned}\text{Shaft } AB \quad \phi_{AB} &= \frac{T L_{AB}}{GJ} = \frac{2TL_{AB}}{\pi G c^4} = \frac{(2)(2500)(0.090)}{\pi(27 \times 10^9)(0.030)^4} \\ &= 6.550 \times 10^{-3} \text{ rad}\end{aligned}$$

Plate BC (See PROBLEM 3.65 for derivation)

$$\begin{aligned}\phi_{BC} &= \frac{T}{4\pi G t} \left\{ \frac{1}{r_1^2} - \frac{1}{r_2^2} \right\} = \frac{2500}{4\pi(27 \times 10^9)(0.006)} \left\{ \frac{1}{0.030^2} - \frac{1}{0.075^2} \right\} \\ &= 1.146 \times 10^{-3} \text{ rad}\end{aligned}$$

$$\text{Shaft } CD \quad \phi_{CD} = \frac{T L_{CD}}{GJ} = \frac{(2500)(0.150)}{(27 \times 10^9)(11.482 \times 10^{-6})} = 1.210 \times 10^{-3} \text{ rad}$$

$$\begin{aligned}\text{Total rotation angle } \phi &= \phi_{AB} + \phi_{BC} + \phi_{CD} = 8.91 \times 10^{-3} \text{ rad} \\ &= 0.510^\circ\end{aligned}$$

PROBLEM 3.67

3.67 Using an allowable stress of 55 MPa, design a solid steel shaft to transmit 10 kW at a frequency of 15 Hz.

SOLUTION

$$\tau_{all} = 55 \times 10^6 \text{ Pa} \quad P = 10 \times 10^3 \text{ W}, \quad f = 15 \text{ Hz}$$

$$T = \frac{P}{2\pi f} = \frac{10 \times 10^3}{2\pi(15)} = 106.10 \text{ N}\cdot\text{m}$$

$$\tau = \frac{Tc}{J} = \frac{2T}{\pi c^3} \therefore c^3 = \frac{2T}{\pi \tau} = \frac{(2)(106.10)}{\pi(55 \times 10^6)} = 1.2281 \times 10^{-6} \text{ m}^3$$

$$c = 10.71 \times 10^{-3} \text{ m} = 10.71 \text{ mm} \quad d = 2c = 21.4 \text{ mm} \quad \blacktriangleleft$$

PROBLEM 3.68

3.68 Using an allowable stress of 5 ksi, design a solid steel shaft to transmit $\frac{1}{2}$ hp at a speed of 1725 rpm.

SOLUTION

$$\tau_{all} = 5 \text{ ksi} = 5000 \text{ psi} \quad P = \frac{1}{2} \text{ hp} = \frac{1}{2}(6600) = 3300 \text{ lb}\cdot\text{in}/\text{s}$$

$$f = \frac{1725}{60} = 28.75 \text{ Hz} \quad T = \frac{P}{2\pi f} = \frac{3300}{2\pi(28.75)} = 18.268 \text{ lb}\cdot\text{in}$$

$$\tau = \frac{Tc}{J} = \frac{2T}{\pi c^3} \therefore c^3 = \frac{2T}{\pi \tau} = \frac{(2)(18.268)}{\pi(5000)} = 2.3260 \times 10^{-3} \text{ in}^3$$

$$c = 0.1325 \text{ in} \quad d = 2c = 0.265 \text{ in} \quad \blacktriangleleft$$

PROBLEM 3.69

3.69 Design a solid steel shaft to transmit 100 hp at a speed of 1200 rpm, if the maximum shearing stress is not to exceed 7500 psi.

SOLUTION

$$\tau_{all} = 7500 \text{ psi} \quad P = 100 \text{ hp} = 660 \times 10^3 \text{ lb}\cdot\text{in}/\text{s}$$

$$f = \frac{1200}{60} = 20 \text{ Hz} \quad T = \frac{P}{2\pi f} = \frac{660 \times 10^3}{2\pi(20)} = 5.2521 \times 10^3 \text{ lb}\cdot\text{in}$$

$$\tau = \frac{Tc}{J} = \frac{2T}{\pi c^3} \therefore c^3 = \frac{2T}{\pi \tau} = \frac{(2)(5.2521 \times 10^3)}{\pi(7500)} = 0.4458 \text{ in}^3$$

$$c = 0.7639 \text{ in} \quad d = 2c = 1.528 \text{ in.} \quad \blacktriangleleft$$

PROBLEM 3.70

3.70 Design a solid steel shaft to transmit 0.375 kW at a frequency of 29 Hz, if the shearing stress in the shaft is not to exceed 35 MPa

SOLUTION

$$\tau_{all} = 35 \times 10^6 \text{ Pa} \quad P = 0.375 \times 10^3 \text{ W} \quad f = 29 \text{ Hz}$$

$$T = \frac{P}{2\pi f} = \frac{0.375 \times 10^3}{2\pi(29)} = 2.0580 \text{ N}\cdot\text{m}$$

$$\tau = \frac{Tc}{J} = \frac{2T}{\pi c^3} \therefore c^3 = \frac{2T}{\pi \tau} = \frac{(2)(2.0580)}{\pi(35 \times 10^6)} = 37.43 \times 10^{-9} \text{ m}^3$$

$$c = 3.345 \times 10^{-3} \text{ m} = 3.345 \text{ mm} \quad d = 2c = 6.69 \text{ mm} \quad \blacktriangleleft$$

PROBLEM 3.71

3.71 A hollow shaft is to transmit 250 kW at a frequency of 30 Hz. Knowing that the shearing stress must not exceed 50 MPa, design a shaft for which the ratio of the inner diameter to the outer diameter is 0.75.

SOLUTION

$$\tau_{all} = 50 \times 10^6 \text{ Pa} \quad P = 250 \times 10^3 \text{ W} \quad f = 30 \text{ Hz}$$

$$T = \frac{P}{2\pi f} = \frac{250 \times 10^3}{2\pi(30)} = 1326.3 \text{ N}\cdot\text{m}$$

$$J = \frac{\pi}{2} (C_2^4 - C_1^4) = \frac{\pi}{2} \left(1 - \left(\frac{3}{4}\right)^4\right) C_2^4 = 1.0738 C_2^4$$

$$\gamma = \frac{T C_2}{J} = \frac{T C_2}{1.0738 C_2^4} \quad \therefore C_2^3 = \frac{T}{1.0738 \gamma} = \frac{1326.3}{(1.0738)(50 \times 10^6)}$$

$$C_2^3 = 24.70 \times 10^{-6} \text{ m}^3$$

$$C_2 = 29.12 \times 10^{-3} \text{ m} = 29.12 \text{ mm} \quad d_2 = 2C_2 = 58.2 \text{ mm} \quad \blacktriangleleft$$

PROBLEM 3.72

3.72 One of two hollow drive shafts of an ocean liner is 125 ft long, and its outer and inner diameters are 16 in. and 8 in., respectively. The shaft is made of a steel for which $\tau_{all} = 8500 \text{ psi}$ and $G = 11.2 \times 10^6 \text{ psi}$. Knowing that the maximum speed of rotation of the shaft is 165 rpm, determine (a) the maximum power that can be transmitted by the one shaft to its propeller, (b) the corresponding angle of twist of the shaft.

SOLUTION

$$C_2 = \frac{1}{2} d_2 = 8 \text{ in}$$

$$C_1 = \frac{1}{2} d_1 = 4 \text{ in}$$

$$J = \frac{\pi}{2} (C_2^4 - C_1^4) = \frac{\pi}{2} (8^4 - 4^4) = 6031.8 \text{ in}^4$$

$$\gamma = \frac{T C_2}{J} \quad \therefore T = \frac{J \gamma}{C_2} = \frac{(6031.8)(8500)}{8} = 6.4088 \times 10^6 \text{ lb}\cdot\text{in}$$

$$f = \frac{165}{60} = 2.75 \text{ Hz}$$

$$(a) P = 2\pi f T = 2\pi(2.75)(6.4088 \times 10^6) = 110.74 \times 10^6 \text{ lb}\cdot\text{in/s}$$

$$\frac{110.74 \times 10^6 \text{ lb}\cdot\text{in/s}}{6600 \text{ lb}\cdot\text{in/s hp}} = 16.78 \times 10^3 \text{ hp.} \quad \blacktriangleleft$$

$$L = 125 \text{ ft} = 1500 \text{ in}$$

$$(b) \phi = \frac{TL}{GJ} = \frac{(6.4088 \times 10^6)(1500)}{(11.2 \times 10^6)(6031.8)} = 0.1423 \text{ rad}$$

$$= 8.15^\circ \quad \blacktriangleleft$$

PROBLEM 3.73

3.73 While a steel shaft of the cross section shown rotates at 120 rpm, a stroboscopic measurement indicates that the angle of twist is 2° in a 4-m length. Using $G = 77$ GPa, determine the power being transmitted.

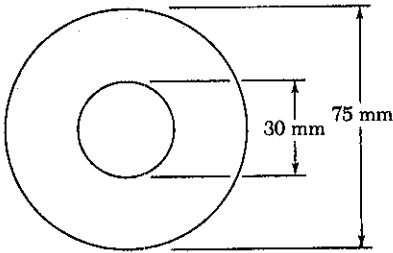

SOLUTION

$$\begin{aligned} \text{Twist angle } \phi &= 2^\circ = 34.907 \times 10^{-3} \text{ rad} \\ c_1 &= \frac{1}{2} d_1 = 0.015 \text{ m}, \quad c_2 = \frac{1}{2} d_2 = 0.0375 \text{ m} \\ J &= \frac{\pi}{2} (c_2^4 - c_1^4) = \frac{\pi}{2} (0.0375^4 - 0.015^4) \\ J &= 3.0268 \times 10^{-6} \text{ m}^4, \quad L = 4 \text{ m} \end{aligned}$$

$$\phi = \frac{TL}{GJ} \quad T = \frac{GJ\phi}{L} = \frac{(77 \times 10^9)(3.0268 \times 10^{-6})(34.907 \times 10^{-3})}{4}$$

$$T = 2.0339 \times 10^3 \text{ N}\cdot\text{m} \quad f = 120 \text{ rpm} = \frac{120}{60} \text{ Hz} = 2 \text{ Hz}$$

$$P = (2\pi f)T = 2\pi(2)(2.0339 \times 10^3) = 25.6 \times 10^3 \text{ W} = 25.6 \text{ kW} \quad \blacktriangleleft$$

PROBLEM 3.74

3.74 Determine the required thickness of the 50-mm tubular shaft of Example 3.07, if it is to transmit the same power while rotating at a frequency of 40 Hz.

SOLUTION

$$\text{From Example 3.07} \quad P = 100 \text{ kW} = 100 \times 10^3 \text{ W}$$

$$\tau_{\text{all}} = 60 \text{ MPa} = 60 \times 10^6 \text{ Pa}$$

$$c_2 = \frac{1}{2} d = 0.025 \text{ m}$$

$$\text{Given } f = 40 \text{ Hz}$$

$$T = \frac{P}{2\pi f} = \frac{100 \times 10^3}{2\pi(40)} = 397.89 \text{ N}\cdot\text{m}$$

$$J = \frac{\pi}{2} (c_2^4 - c_1^4) \quad \tau = \frac{TC_2}{J} = \frac{TC_2}{\frac{\pi}{2}(c_2^4 - c_1^4)} \quad \therefore c_1^4 = c_2^4 - \frac{2TC_2}{\pi\tau}$$

$$c_1^4 = c_2^4 - \frac{2TC_2}{\pi\tau} = 0.025^4 - \frac{(2)(397.89)(0.025)}{\pi(60 \times 10^6)} = 285.081 \times 10^{-9} \text{ m}^4$$

$$c_1 = 23.11 \times 10^{-3} \text{ m} \quad t = c_2 - c_1 = 1.89 \times 10^{-3} \text{ m} = 1.89 \text{ mm} \quad \blacktriangleleft$$

PROBLEM 3.75

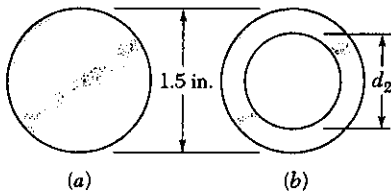

3.75 The design of a machine element calls for a 1.5-in.-outer-diameter shaft to transmit 60 hp. (a) If the speed of rotation is 720 rpm, determine the maximum shearing stress in shaft *a*. (b) If the speed of rotation can be increased 50% to 1080 rpm, determine the largest inner diameter of shaft *b* for which the maximum shearing stress will be the same in each shaft.

SOLUTION

$$P = 60 \text{ hp} = (60)(6600) = 396 \times 10^3 \text{ lb}\cdot\text{in}/\text{s}$$

$$f = \frac{720}{60} = 12 \text{ Hz} \quad c = \frac{1}{2}d = 0.75 \text{ in}$$

$$T = \frac{P}{2\pi f} = \frac{396 \times 10^3}{2\pi(12)} = 5.2521 \times 10^3 \text{ lb}\cdot\text{in}$$

$$(a) \tau = \frac{Tc}{J} = \frac{2T}{\pi c^3} = \frac{(2)(5.2521 \times 10^3)}{\pi(0.75)^3} = 7.9256 \times 10^3 \text{ psi}$$

7.93 ksi

$$(b) f = \frac{1080}{60} = 18 \text{ Hz} \quad c_2 = \frac{1}{2}d_2 = 0.75 \text{ in}$$

$$T = \frac{P}{2\pi f} = \frac{396 \times 10^3}{2\pi(18)} = 3.5014 \times 10^3 \text{ lb}\cdot\text{in}$$

$$\tau = \frac{Tc_2}{J} = \frac{2Tc_2}{\pi(c_2^4 - c_1^4)}$$

$$c_1^4 = c_2^4 - \frac{2Tc_2}{\pi\tau} = 0.75^4 - \frac{(2)(3.5014 \times 10^3)(0.75)}{\pi(7.9256 \times 10^3)} = 0.10547 \text{ in}^4$$

$$c_1 = 0.5699 \text{ in} \quad d_1 = 2c_1 = 1.140 \text{ in}$$

PROBLEM 3.76

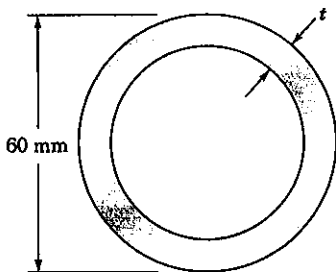

3.76 A steel pipe of 60-mm outer diameter is to be used to transmit a torque of 350 N·m without exceeding an allowable shearing stress of 12 MPa. A series of 60-mm-outer-diameter pipes is available for use. Knowing that the wall thickness of the available pipes varies from 4 mm to 10 mm in 2-mm increments, choose the lightest pipe that can be used.

SOLUTION

$$\tau_{\text{all}} = 60 \times 10^6 \text{ Pa} \quad c_2 = \frac{1}{2}d_2 = 0.030 \text{ m}$$

$$\tau = \frac{Tc_2}{J} = \frac{2Tc_2}{\pi(c_2^4 - c_1^4)}$$

$$c_1^4 = c_2^4 - \frac{2Tc_2}{\pi\tau} = 0.030^4 - \frac{(2)(350)(0.030)}{\pi(60 \times 10^6)} = 252.96 \times 10^{-9} \text{ m}^4$$

$$c_1 = 22.43 \times 10^{-3} \quad t = c_2 - c_1 = 30 \text{ mm} - 22.43 \text{ mm} = 7.57 \text{ mm}$$

Required thickness $t > 7.59 \text{ mm}$. Available size $t = 8 \text{ mm}$

PROBLEM 3.77

3.77 A steel drive shaft is 6 ft long and its outer and inner diameters are respectively equal to 2.25 in. and 1.75 in. (a) Knowing that the shaft transmits 240 hp while rotating at 1800 rpm, determine the maximum shearing stress. (b) Using $G = 11.2 \times 10^6$ psi, determine the corresponding angle of twist of the shaft.

SOLUTION

$$c_1 = \frac{1}{2}d_1 = 0.875 \text{ in}, \quad c_2 = \frac{1}{2}d_2 = 1.125 \text{ in}, \quad L = 6\text{ft} = 72 \text{ in}$$

$$P = 240 \text{ hp} = (240)(6600) = 1.584 \times 10^6 \text{ lb}\cdot\text{in}/\text{s}$$

$$f = \frac{1800}{60} = 30 \text{ Hz}$$

$$T = \frac{P}{2\pi f} = \frac{1.584 \times 10^6}{2\pi(30)} = 8.4034 \times 10^3 \text{ lb}\cdot\text{in.}$$

$$J = \frac{\pi}{2}(c_2^4 - c_1^4) = \frac{\pi}{2}(1.125^4 - 0.875^4) = 1.59530 \text{ in}^4$$

$$(a) \quad \tau = \frac{Tc_2}{J} = \frac{(8.4034 \times 10^3)(1.125)}{1.59530} = 5926 \text{ psi}$$

$$(b) \quad \phi = \frac{TL}{GJ} = \frac{(8.4034 \times 10^3)(72)}{(11.2 \times 10^6)(1.59530)} = 33.86 \times 10^{-3} \text{ rad} = 1.940^\circ$$

PROBLEM 3.78

3.78 Knowing that the allowable shearing stress of the steel to be used is 7500 psi, determine (a) the smallest permissible diameter of a shaft which must transmit 15 hp while rotating at 2000 rpm, (b) the corresponding angle of twist in a 4-ft length of the shaft ($G = 11.2 \times 10^6$ psi).

SOLUTION

$$\tau_{\text{all}} = 7500 \text{ psi}, \quad f = \frac{2000}{60} = 33.333 \text{ Hz}$$

$$P = 15 \text{ hp} = (15)(6600) = 99 \times 10^3 \text{ lb}\cdot\text{in}/\text{s}$$

$$T = \frac{P}{2\pi f} = \frac{99 \times 10^3}{2\pi(33.333)} = 472.69 \text{ lb}\cdot\text{in}$$

$$(a) \quad \tau = \frac{Tc}{J} = \frac{2T}{\pi c^3} \quad \therefore c^3 = \frac{2T}{\pi \tau} = \frac{(2)(472.69)}{\pi(7500)} = 40.123 \times 10^{-3} \text{ in}^3$$

$$c = 0.3425 \text{ in} \quad d = 2c = 0.685 \text{ in.}$$

$$(b) \quad J = \frac{\pi}{4}c^4 = \frac{\pi}{4}(0.3425)^4 = 21.516 \times 10^{-3} \text{ in}^4$$

$$L = 4\text{ft} = 48 \text{ in}$$

$$\phi = \frac{TL}{GJ} = \frac{(472.69)(48)}{(11.2 \times 10^6)(21.516 \times 10^{-3})} = 93.89 \times 10^{-3} \text{ rad} = 5.38^\circ$$

PROBLEM 3.79

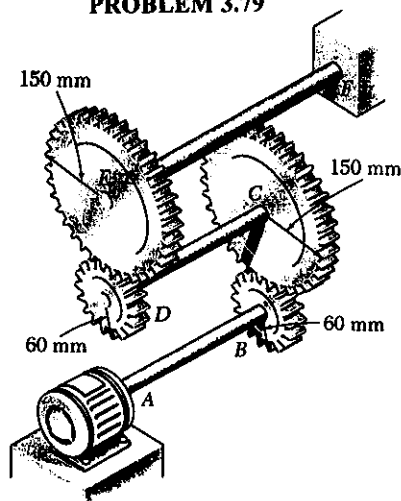

3.79 Three shafts and four gears are used to form a gear train which will transmit 7.5 kW from the motor at A to a machine tool at F. (Bearing for the shafts are omitted in the sketch.) Knowing that the frequency of the motor is 30 Hz and that the allowable stress for each shaft is 60 MPa, determine the required diameter of each shaft.

SOLUTION

$$P = 7.5 \text{ kW} = 7.5 \times 10^3 \text{ W}$$

$$\tau_{all} = 60 \text{ MPa} = 60 \times 10^6 \text{ Pa}$$

Shaft AB: $f_{AB} = 30 \text{ Hz}$

$$T_{AB} = \frac{P}{2\pi f_{AB}} = \frac{7.5 \times 10^3}{2\pi(30)} = 39.789 \text{ N}\cdot\text{m}$$

$$\tau = \frac{T C_{AB}}{J_{AB}} = \frac{2T}{\pi C_{AB}^3} \therefore C_{AB}^3 = \frac{2T}{\pi \tau}$$

$$C_{AB}^3 = \frac{(2)(39.789)}{\pi(60 \times 10^6)} = 422.17 \times 10^{-9} \text{ m}^3$$

$$C_{AB} = 7.50 \times 10^{-3} \text{ m} = 7.50 \text{ mm}$$

$$d_{AB} = 2C_{AB} = 15.00 \text{ mm} \quad \blacktriangleleft$$

Shaft CD:

$$f_{CD} = \frac{r_D}{r_C} f_{AB} = \frac{60}{150} (30) = 12 \text{ Hz}$$

$$T_{CD} = \frac{P}{2\pi f_{CD}} = \frac{7.5 \times 10^3}{2\pi(12)} = 99.472 \text{ N}\cdot\text{m}$$

$$\tau = \frac{T C_{CD}}{J_{CD}} = \frac{2T}{\pi C_{CD}^3} \therefore C_{CD}^3 = \frac{2T_{CD}}{\pi \tau} = \frac{2(99.472)}{\pi(60 \times 10^6)} = 1.05543 \times 10^{-6} \text{ m}^3$$

$$C_{CD} = 10.18 \times 10^{-3} \text{ m} = 10.18 \text{ mm}$$

$$d_{CD} = 2C_{CD} = 20.4 \text{ mm} \quad \blacktriangleleft$$

Shaft EF:

$$f_{EF} = \frac{r_C}{r_E} f_{CD} = \frac{60}{150} (12) = 4.8 \text{ Hz}$$

$$T_{EF} = \frac{P}{2\pi f_{EF}} = \frac{7.5 \times 10^3}{2\pi(4.8)} = 248.68 \text{ N}\cdot\text{m}$$

$$\tau = \frac{T C_{EF}}{J_{EF}} = \frac{2T}{\pi C_{EF}^3} \therefore C_{EF}^3 = \frac{(2)(248.68)}{\pi(60 \times 10^6)} = 2.6886 \times 10^{-6} \text{ m}^3$$

$$C_{EF} = 13.82 \times 10^{-3} = 13.82 \text{ mm}$$

$$d_{EF} = 2C_{EF} = 27.6 \text{ mm} \quad \blacktriangleleft$$

PROBLEM 3.80

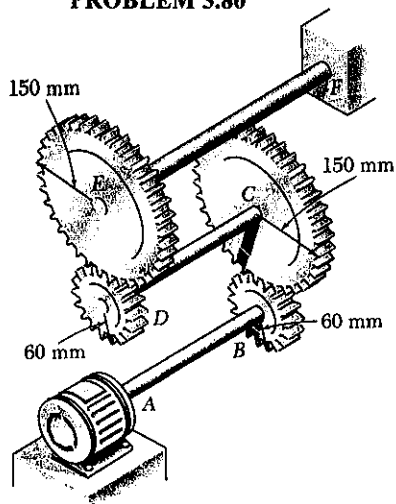

3.80 Three shafts and four gears are used to form a gear train which will transmit power from the motor at *A* to a machine tool at *F*. (Bearing for the shafts are omitted in the sketch.) The diameter of each shaft is as follows: $d_{AB} = 16$ mm, $d_{CD} = 20$ mm, $d_{EF} = 28$ mm. Knowing that the frequency of the motor is 24 Hz and that the allowable shearing stress for each shaft is 75 MPa, determine the maximum power that can be transmitted.

SOLUTION

$$\tau_{all} = 75 \text{ MPa} = 75 \times 10^6 \text{ Pa}$$

$$\text{Shaft AB: } C_{AB} = \frac{1}{2} d_{AB} = 0.008 \text{ m}$$

$$\tau = \frac{T C_{AB}}{J_{AB}} = \frac{2T}{\pi C_{AB}^3}$$

$$T_{all} = \frac{\pi}{2} C_{AB}^3 \tau_{all} = \frac{\pi}{2} (0.008)^3 (75 \times 10^6) = 60.319 \text{ N}\cdot\text{m}$$

$$f_{AB} = 24 \text{ Hz}$$

$$P_{all} = 2\pi f_{AB} T_{all} = 2\pi (24)(60.319) = 9.10 \times 10^3 \text{ W}$$

$$\text{Shaft CD: } C_{CD} = \frac{1}{2} d_{CD} = 0.010 \text{ m}$$

$$\tau = \frac{T C_{CD}}{J_{CD}} = \frac{2T}{\pi C_{CD}^3} \quad \therefore \quad T_{all} = \frac{\pi}{2} C_{CD}^3 \tau_{all} = \frac{\pi}{2} (0.010)^3 (75 \times 10^6) = 117.81 \text{ N}\cdot\text{m}$$

$$f_{CD} = \frac{r_B}{r_C} f_{AB} = \frac{60}{150} (24) = 9.6 \text{ Hz}$$

$$P_{all} = 2\pi f_{CD} T_{all} = 2\pi (9.6)(117.81) = 7.11 \times 10^3 \text{ W}$$

$$\text{Shaft EF: } C_{EF} = \frac{1}{2} d_{EF} = 0.014 \text{ m}$$

$$T_{all} = \frac{\pi}{2} C_{EF}^3 \tau_{all} = \frac{\pi}{2} (0.014)^3 (75 \times 10^6) = 323.27 \text{ N}\cdot\text{m}$$

$$f_{EF} = \frac{r_D}{r_E} f_{CD} = \frac{60}{150} (9.6) = 3.84 \text{ Hz}$$

$$P_{all} = 2\pi f_{EF} T_{all} = 2\pi (3.84)(323.27) = 7.80 \times 10^3 \text{ W}$$

Maximum allowable power is the smaller

$$P_{all} = 7.11 \times 10^3 \text{ W} = 7.11 \text{ kW}$$

PROBLEM 3.81

3.81 The shaft-disk-belt arrangement shown is used to transmit 3 hp from point A to point D. (a) Using an allowable shearing stress of 9500 psi, determine the required speed of shaft AB. (b) Solve part a, assuming that the diameters of shafts AB and CD are respectively 0.75 in. and 0.625 in.

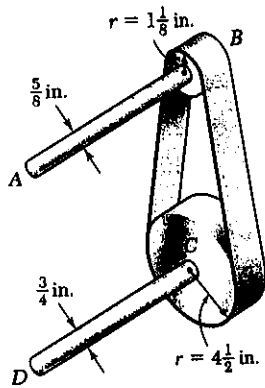

SOLUTION

$$\tau = 9500 \text{ psi}, \quad P = 3 \text{ hp} = (3)(6600) = 19800 \text{ lb}\cdot\text{in}/\text{s}$$

$$\tau = \frac{Tc}{J} = \frac{2T}{\pi c^3} \quad T = \frac{\pi}{2} c^3 \tau$$

Allowable torques

$\frac{5}{8}$ in. diameter shaft

$$c = \frac{5}{16} \text{ in}, \quad T_{all} = \frac{\pi}{2} \left(\frac{5}{16}\right)^3 (9500) = 455.4 \text{ lb}\cdot\text{in}$$

$\frac{3}{4}$ in diameter shaft

$$c = \frac{3}{8} \text{ in}, \quad T_{all} = \frac{\pi}{2} \left(\frac{3}{8}\right)^3 (9500) = 786.9 \text{ lb}\cdot\text{in}$$

Statics:

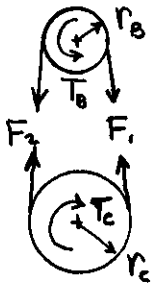

$$T_B = r_B (F_1 - F_2) \quad T_C = r_C (F_1 - F_2)$$

$$T_B = \frac{r_B}{r_C} T_C = \frac{1.125}{4.5} T_C = 0.25 T_C$$

(a) Allowable torques $T_{B,all} = 455.4 \text{ lb}\cdot\text{in}, \quad T_{C,all} = 786.9 \text{ lb}\cdot\text{in}$

Assume $T_C = 786.9 \text{ lb}\cdot\text{in}$. Then $T_B = (0.25)(786.9) = 196.73 \text{ lb}\cdot\text{in}$
 $< 455.4 \text{ lb}\cdot\text{in}$ (okay)

$$P = 2\pi f T \quad f_{AB} = \frac{P}{2\pi T_B} = \frac{19800}{2\pi(196.73)} = 16.02 \text{ Hz}$$

(b) Allowable torques $T_{B,all} = 786.9 \text{ lb}\cdot\text{in}, \quad T_{C,all} = 455.4 \text{ lb}\cdot\text{in}$

Assume $T_C = 455.4 \text{ lb}\cdot\text{in}$. Then $T_B = (0.25)(455.4) = 113.85 \text{ lb}\cdot\text{in}$
 $< 786.9 \text{ lb}\cdot\text{in}$

$$P = 2\pi f T \quad f_{AB} = \frac{P}{2\pi T_B} = \frac{19800}{2\pi(113.85)} = 27.7 \text{ Hz}$$

PROBLEM 3.82

3.82 A steel shaft must transmit 150 kW at a speed of 360 rpm. Knowing that $G = 77$ GPa, design a solid shaft so that the maximum stress will not exceed 50 MPa and the angle of twist in a 2.5-m length will not exceed 3° .

SOLUTION

$$P = 150 \times 10^3 \text{ W} \quad f = \frac{360}{60} = 6 \text{ Hz}$$

$$T = \frac{P}{2\pi f} = \frac{150 \times 10^3}{2\pi(6)} = 3.9789 \times 10^3 \text{ N}\cdot\text{m}$$

Design for stress limit $\tau = 50 \text{ MPa} = 50 \times 10^6 \text{ Pa}$

$$\tau = \frac{Tc}{J} = \frac{2T}{\pi c^3} \therefore c^3 = \frac{2T}{\pi \tau} = \frac{(2)(3.9789 \times 10^3)}{\pi(50 \times 10^6)} = 50.661 \times 10^{-6} \text{ m}^3$$

$$c = 37.00 \times 10^{-3} \text{ m}$$

Design for angle of twist limit $\phi = 3^\circ = 52.36 \times 10^{-3} \text{ rad}$

$$\phi = \frac{TL}{GJ} = \frac{2TL}{\pi Gc^4} \therefore c^4 = \frac{2TL}{\pi G\phi} = \frac{(2)(3.9789 \times 10^3)(2.5)}{\pi(77 \times 10^9)(52.36 \times 10^{-3})} = 1.5707 \times 10^{-6} \text{ m}^4$$

$$c = 35.40 \times 10^{-3} \text{ m}$$

Use larger value $c = 37.00 \times 10^{-3} \text{ m} = 37.0 \text{ mm}$; $d = 2c = 74.0 \text{ mm}$ ◀

PROBLEM 3.83

3.83 A steel shaft of 1.5-m length and 48-mm diameter is to be used to transmit 36 kW between a motor and a machine tool. Knowing that $G = 77$ GPa, determine the lowest speed of rotation of the shaft at which the maximum stress will not exceed 60 MPa and the angle of twist will not exceed 2.5° .

SOLUTION

$$P = 36 \times 10^3 \text{ W}, \quad c = \frac{1}{2}d = 0.024 \text{ m}, \quad L = 1.5 \text{ m}, \quad G = 77 \times 10^9 \text{ Pa}$$

Torque based on maximum stress $\tau = 60 \text{ MPa} = 60 \times 10^6 \text{ Pa}$

$$\tau = \frac{Tc}{J} \therefore T = \frac{J\tau}{c} = \frac{\pi}{2} c^3 \tau = \frac{\pi}{2} (0.024)^3 (60 \times 10^6) = 1.30288 \times 10^3 \text{ N}\cdot\text{m}$$

Torque based on twist angle $\phi = 2.5^\circ = 43.633 \times 10^{-3} \text{ rad}$

$$\phi = \frac{TL}{GJ} \therefore T = \frac{GJ\phi}{L} = \frac{\pi c^4 G \phi}{2L} = \frac{\pi (0.024)^4 (77 \times 10^9) (43.633 \times 10^{-3})}{(2)(1.5)}$$

$$= 1.16730 \times 10^3 \text{ N}\cdot\text{m}$$

Smaller torque governs $T = 1.16730 \times 10^3 \text{ N}\cdot\text{m}$

$$P = 2\pi f T \therefore f = \frac{P}{2\pi T} = \frac{36 \times 10^3}{2\pi (1.16730 \times 10^3)} = 4.91 \text{ Hz} \quad \blacktriangleleft$$

PROBLEM 3.84

3.84 A 1.5-in.-diameter steel shaft of length 4 ft will be used to transmit 60 hp between a motor and a pump. Knowing that $G = 11.2 \times 10^6$ psi, determine the lowest speed of rotation at which the shearing stress will not exceed 8500 psi and the angle of twist will not exceed 2° .

SOLUTION

$$c = \frac{1}{2}d = 0.75 \text{ in.}, \quad L = 4 \text{ ft} = 48 \text{ in.}$$

Torque based on maximum shearing stress limit $\tau = 8500 \text{ psi}$

$$\tau = \frac{Tc}{J} = \frac{2T}{\pi c^3} \quad \therefore T = \frac{\pi c^3 \tau}{2} = \frac{\pi (0.75)^3 (8500)}{2} = 5.633 \times 10^3 \text{ lb}\cdot\text{in}$$

Torque based on twist angle limit $\phi = 2^\circ = 34.907 \times 10^{-3} \text{ rad}$

$$\phi = \frac{TL}{GJ} \quad \therefore T = \frac{GJ\phi}{L} = \frac{\pi c^4 G \phi}{2L} = \frac{\pi (0.75)^4 (11.2 \times 10^6) (34.907 \times 10^{-3})}{(2)(48)}$$

$$= 4.048 \times 10^3 \text{ lb}\cdot\text{in}$$

Smaller torque governs $T = 4.048 \times 10^3 \text{ lb}\cdot\text{in}$

$$P = 2\pi f T \quad \text{where } P = 60 \text{ hp} = (60)(6600) = 396 \times 10^3 \text{ lb}\cdot\text{in/s}$$

$$f = \frac{P}{2\pi T} = \frac{396 \times 10^3}{2\pi (4.048 \times 10^3)} = 15.57 \text{ Hz} = 934 \text{ rpm}$$

PROBLEM 3.85

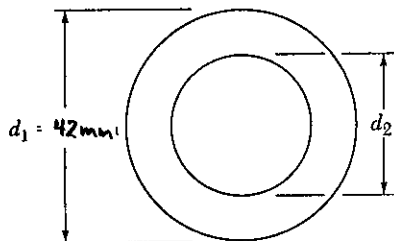

3.85 A 1.6-m-long tubular shaft of 42-mm outer diameter d_1 having the cross section shown is to be made of a steel for which $\tau_{\text{all}} = 75 \text{ MPa}$ and $G = 77 \text{ GPa}$. Knowing that the angle of twist of the shaft must not exceed 4° when the shaft is subjected to a torque of 900 N·m, determine the largest inner diameter d_2 which can be specified in the design.

SOLUTION

$$c_1 = \frac{1}{2}d_1 = 0.021 \text{ m} \quad L = 1.6 \text{ m}$$

Based on stress limit $\tau = 75 \text{ MPa} = 75 \times 10^6 \text{ Pa}$

$$\tau = \frac{Tc_1}{J} \quad \therefore J = \frac{Tc_1}{\tau} = \frac{(900)(0.021)}{75 \times 10^6} = 252 \times 10^{-9} \text{ m}^4$$

Based on angle of twist limit $\phi = 4^\circ = 69.813 \times 10^{-3} \text{ rad}$

$$\phi = \frac{TL}{GJ} \quad \therefore J = \frac{TL}{G\phi} = \frac{(900)(1.6)}{(77 \times 10^9)(69.813 \times 10^{-3})} = 267.88 \times 10^{-9} \text{ m}^4$$

Larger value for J governs $J = 267.88 \times 10^{-9} \text{ m}^4$

$$J = \frac{\pi}{2} (c_1^4 - c_2^4)$$

$$c_2^4 = c_1^4 - \frac{2J}{\pi} = 0.021^4 - \frac{(2)(267.88 \times 10^{-9})}{\pi} = 23.943 \times 10^{-9} \text{ m}^4$$

$$c_2 = 12.44 \times 10^{-3} \text{ m} = 12.44 \text{ mm}$$

$$d_2 = 2c_2 = 24.9 \text{ mm}$$

PROBLEM 3.86

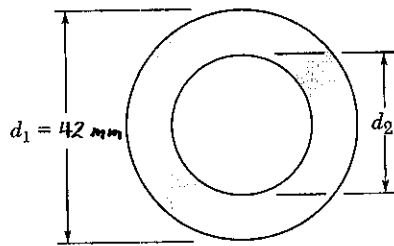

3.86 A 1.6-m-long tubular steel shaft ($G = 77 \text{ GPa}$) of 42-mm outer diameter d_1 and 30-mm inner diameter d_2 is to transmit 120 kW between a turbine and a generator. Knowing that the allowable shearing stress is 65 MPa and that the angle of twist must not exceed 3° , determine the minimum frequency at which the shaft may rotate.

SOLUTION

$$c_1 = \frac{1}{2}d_1 = 0.021 \text{ m}, \quad c_2 = \frac{1}{2}d_2 = 0.015 \text{ m}$$

$$J = \frac{\pi}{2}(c_1^4 - c_2^4) = \frac{\pi}{2}(0.021^4 - 0.015^4) = 225.97 \times 10^{-9} \text{ m}^4$$

Based on stress limit $\tau = 65 \text{ MPa} = 65 \times 10^6 \text{ Pa}$

$$\tau = \frac{Tc_1}{J} \therefore T = \frac{J\tau}{c_1} = \frac{(225.97 \times 10^{-9})(65 \times 10^6)}{0.021} = 699.43 \text{ N}\cdot\text{m}$$

Based on angle of twist limit $\phi = 3^\circ = 52.36 \times 10^{-3} \text{ rad}$

$$\phi = \frac{TL}{GJ} \therefore T = \frac{GJ\phi}{L} = \frac{(77 \times 10^9)(225.97 \times 10^{-9})(52.36 \times 10^{-3})}{1.6} \\ = 569.40 \text{ N}\cdot\text{m}$$

Smaller torque governs $T = 569.40 \text{ N}\cdot\text{m}$

$$P = 120 \text{ kW} = 120 \times 10^3 \text{ W}$$

$$P = 2\pi fT \therefore f = \frac{P}{2\pi T} = \frac{120 \times 10^3}{2\pi(569.40)} = 33.54 \text{ Hz} \\ = 2012 \text{ rpm}$$

PROBLEM 3.87

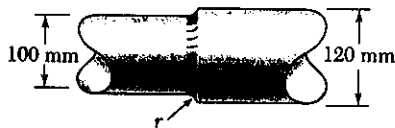

3.87 The stepped shaft shown rotates at 450 rpm. Knowing that $r = 10$ mm, determine the maximum power that can be transmitted without exceeding an allowable shearing stress of 45 MPa.

SOLUTION

$$d = 100 \text{ mm}, \quad D = 120 \text{ mm}, \quad r = 10 \text{ mm}$$

$$\frac{D}{d} = \frac{120}{100} = 1.2, \quad \frac{r}{d} = \frac{10}{100} = 0.10, \quad \text{From Fig. 3.32} \quad K = 1.33$$

For smaller shaft $c = \frac{1}{2}d = 0.050 \text{ m}$

$$\tau = \frac{KTc}{J} = \frac{2KT}{\pi c^3}$$

$$T = \frac{\pi c^3 \tau}{2K} = \frac{\pi (0.050)^3 (45 \times 10^6)}{(2)(1.33)} = 6.643 \times 10^3 \text{ N}\cdot\text{m}$$

$$f = 450 \text{ rpm} = 7.5 \text{ Hz}$$

Power $P = 2\pi fT = 2\pi (7.5)(6.643 \times 10^3) = 313 \times 10^3 \text{ W} = 313 \text{ kW}$ \blacktriangleleft

PROBLEM 3.88

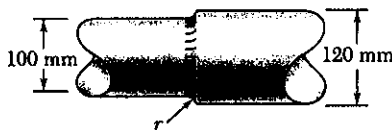

3.88 The stepped shaft shown rotates at 450 rpm. Knowing that $r = 4$ mm, determine the maximum power that can be transmitted without exceeding an allowable shearing stress of 45 MPa.

SOLUTION

$$d = 100 \text{ mm}, \quad D = 120 \text{ mm}, \quad r = 4 \text{ mm}$$

$$\frac{D}{d} = \frac{120}{100} = 1.2, \quad \frac{r}{d} = \frac{4}{100} = 0.04. \quad \text{From Fig. 3.32} \quad K = 1.55$$

For smaller shaft $c = \frac{1}{2}d = 0.050 \text{ m}$

$$\tau = \frac{KTc}{J} = \frac{2KT}{\pi c^3}$$

$$T = \frac{\pi c^3 \tau}{2K} = \frac{\pi (0.050)^3 (45 \times 10^6)}{(2)(1.55)} = 5.70 \times 10^3 \text{ N}\cdot\text{m}$$

$$f = 450 \text{ rpm} = 7.5 \text{ Hz}$$

Power $P = 2\pi fT = 2\pi (7.5)(5.70 \times 10^3) = 268 \times 10^3 \text{ W} = 268 \text{ kW}$ \blacktriangleleft

PROBLEM 3.89

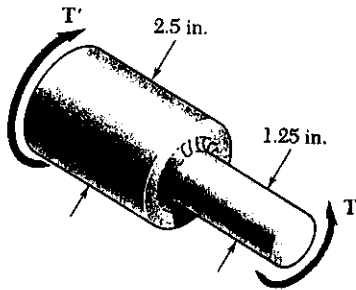

3.89 Knowing that the stepped shaft shown must transmit 60 hp at a speed of 2100 rpm, determine the minimum radius r of the fillet if an allowable stress of 6000 psi is not to be exceeded.

SOLUTION

$$f = \frac{2100}{60} = 35 \text{ Hz}$$

$$P = 60 \text{ hp} = (60)(6600) = 396 \times 10^3 \text{ lb}\cdot\text{in}/\text{s}$$

$$T = \frac{P}{2\pi f} = \frac{396 \times 10^3}{2\pi (35)} = 1.8007 \times 10^3 \text{ lb}\cdot\text{in}$$

For smaller shaft $c = \frac{1}{2}d = 0.625 \text{ in}$

$$\tau = K \frac{Tc}{J} = \frac{2KT}{\pi c^3}$$

$$K = \frac{\pi c^3 \tau}{2T} = \frac{\pi (0.625)^3 (6000)}{(2)(1.8007 \times 10^3)} = 1.28$$

$$\frac{D}{d} = \frac{2.5}{1.25} = 2$$

From Fig 3.32

$$\frac{r}{d} = 0.18$$

$$r = 0.18 d = (0.050)(1.25 \text{ in}) = 0.225 \text{ in.}$$

PROBLEM 3.90

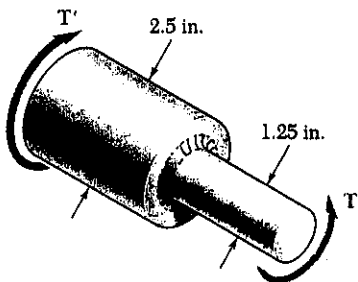

3.90 The stepped shaft shown must transmit 60 hp. Knowing that the allowable shearing stress in the shaft is 6000 psi and that the radius of the fillet is $r = 0.25 \text{ in.}$, determine the smallest permissible speed of the shaft.

SOLUTION

$$\frac{r}{d} = \frac{0.25}{1.25} = 0.200, \quad \frac{D}{d} = \frac{2.5}{1.25} = 2.00$$

From Fig. 3.32 $K = 1.26$

For smaller shaft $c = \frac{1}{2}d = 0.625$

$$\tau = \frac{KTc}{J} = \frac{2KT}{\pi c^3}$$

$$T = \frac{\pi c^3 \tau}{2K} = \frac{\pi (0.625)^3 (6000)}{(2)(1.26)} = 1.826 \times 10^3 \text{ lb}\cdot\text{in}$$

$$P = 60 \text{ hp} = (60)(6600) = 396 \times 10^3 \text{ lb}\cdot\text{in}/\text{s}$$

$$P = 2\pi f T \therefore f = \frac{P}{2\pi T} = \frac{396 \times 10^3}{2\pi (1.826 \times 10^3)} = 34.9 \text{ Hz}$$

$$= 2076 \text{ rpm}$$

PROBLEM 3.91

3.91 A 25-N·m torque is applied to the stepped shaft shown which has a full quarter-circular fillet. Knowing that $D = 24$ mm, determine the maximum shearing stress in the shaft when (a) $d = 20$ mm, (b) $d = 21.6$ mm.

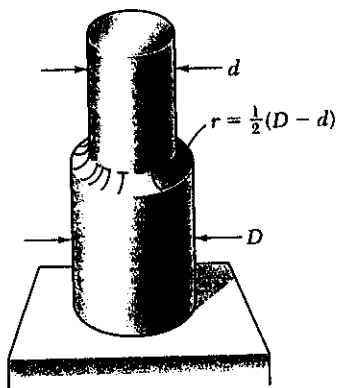

Full quarter-circular fillet extends to edge of larger shaft

SOLUTION

$$(a) \quad \frac{D}{d} = \frac{24}{20} = 1.20$$

$$r = \frac{1}{2}(D - d) = \frac{1}{2}(24 - 20) = 2 \text{ mm}$$

$$\frac{r}{d} = \frac{2}{20} = 0.10$$

From Fig 3.32 $K = 1.34$

For smaller shaft $r = \frac{1}{2}d = 0.010 \text{ m}$

$$\tau = \frac{KTc}{J} = \frac{2KT}{\pi c^3} = \frac{(2)(1.34)(25)}{\pi(0.010)^3} = 21.3 \times 10^6 \text{ Pa} = 21.6 \text{ MPa} \blacktriangleleft$$

$$(b) \quad \frac{D}{d} = \frac{24}{21.6} = 1.111$$

$$r = \frac{1}{2}(D - d) = \frac{1}{2}(24 - 21.6) = 1.2 \text{ mm} \quad \frac{r}{d} = \frac{1.2}{21.6} = 0.0556$$

From Fig 3.32 $K = 1.42$. For smaller shaft $c = \frac{1}{2}d = 0.0108 \text{ m}$.

$$\tau = \frac{KTc}{J} = \frac{2KT}{\pi c^3} = \frac{(2)(1.42)(25)}{\pi(0.0108)^3} = 17.9 \times 10^6 \text{ Pa} = 17.9 \text{ MPa} \blacktriangleleft$$

PROBLEM 3.92

3.92 In the stepped shaft shown, which has a full quarter-circular fillet, $D = 1.5$ in. and $d = 1.2$ in. Knowing that the speed of the shaft is 1800 rpm and that the allowable shearing stress is 8000 psi, determine the maximum power that may be transmitted by the shaft.

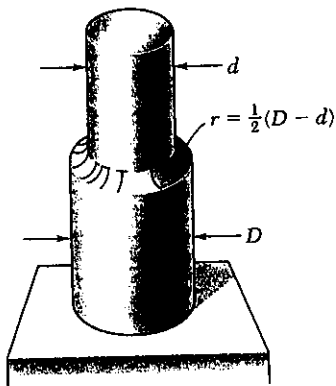

Full quarter-circular fillet extends to edge of larger shaft

SOLUTION

$$\frac{D}{d} = \frac{1.5}{1.2} = 1.25 \quad r = \frac{1}{2}(D - d) = \frac{1}{2}(1.5 - 1.2) = 0.15 \text{ in}$$

$$\frac{r}{d} = \frac{0.15}{1.2} = 0.125$$

From Fig. 3.32 $K = 1.31$

For smaller shaft $c = \frac{1}{2}d = 0.6$ in

$$\tau = \frac{KTc}{J} \quad T = \frac{J\tau}{Kc} = \frac{\pi c^3 \tau}{2K}$$

$$T = \frac{\pi(0.6)^3(8000)}{(2)(1.31)} = 2072 \text{ lb}\cdot\text{in}$$

$$f = 1800 \text{ rpm} = 30 \text{ Hz}$$

Power $P = 2\pi f T = 2\pi(30)(2072) = 390.6 \times 10^3 \text{ lb}\cdot\text{in/s}$

$$\frac{390.6 \times 10^3 \text{ lb}\cdot\text{in/s}}{6600 \text{ lb}\cdot\text{in/s/hp}} = 59.2 \text{ hp} \blacktriangleleft$$

PROBLEM 3.93

3.93 In the stepped shaft shown, which has a full quarter-circular fillet, the allowable shearing stress is 12 ksi. Knowing that $D = 1.25$ in, determine the largest allowable torque that may be applied to the shaft if (a) $d = 1.1$ in., (b) $d = 1.0$ in.

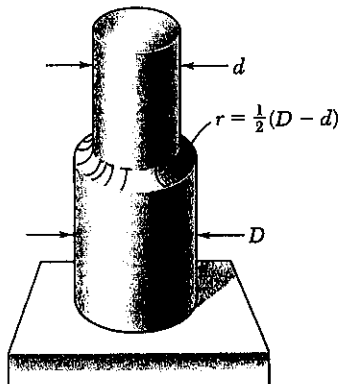

Full quarter-circular fillet extends to edge of larger shaft

SOLUTION

$$\tau_{all} = 12 \text{ ksi} = 12000 \text{ psi}$$

$$(a) \quad D = 1.25 \quad d = 1.1 \text{ in} \quad \frac{D}{d} = \frac{1.25}{1.1} = 1.09$$

$$r = \frac{1}{2}(D - d) = \frac{1}{2}(1.25 - 1.1) = 0.075 \text{ in}$$

$$\frac{r}{d} = \frac{0.075}{1.1} = 0.0682$$

$$\text{From Fig 3.32} \quad K = 1.40$$

$$\text{For smaller shaft} \quad c = \frac{1}{2}d = 0.55 \text{ in}$$

$$\tau = \frac{K T c}{J} \quad \therefore T = \frac{J \tau}{K c} = \frac{\pi c^3 \tau}{2K} = \frac{\pi (0.55)^3 (12000)}{(2)(1.40)} = 2240 \text{ lb-in}$$

$$(b) \quad D = 1.25 \text{ in.} \quad d = 1.0 \text{ in} \quad r = \frac{1}{2}(D - d) = \frac{1}{2}(1.25 - 1.0) = 0.125 \text{ in.}$$

$$\frac{D}{d} = \frac{1.25}{1.0} = 1.25, \quad \frac{r}{d} = \frac{0.125}{1.0} = 0.125 \quad \text{From Fig 3.32} \quad K = 1.81$$

$$\text{For smaller shaft} \quad c = \frac{1}{2}d = 0.50 \text{ in}$$

$$T = \frac{\pi c^3 \tau}{2K} = \frac{\pi (0.50)^3 (12000)}{(2)(1.81)} = 179.8 \text{ lb-in}$$

PROBLEM 3.94

3.94 A 54-mm-diameter solid shaft is made of mild steel which is assumed to be elastoplastic with $\tau_y = 145$ MPa. Determine the maximum shearing stress and the radius of the elastic core caused by the application of a torque of magnitude (a) 4 kN·m, (b) 5 kN·m.

SOLUTION

$$c = \frac{1}{2}d = 0.027 \text{ m} \quad \tau_y = 145 \times 10^6 \text{ Pa}$$

Compute T_y $T_y = \frac{\pi}{2}c^3\tau_y = \frac{\pi}{2}(0.027)^3(145 \times 10^6) = 4.488 \times 10^3 \text{ N}\cdot\text{m}$

(a) $T = 4.0 \times 10^3 \text{ N}\cdot\text{m} < T_y$ elastic $\rho = c = 27 \text{ mm}$ \blacktriangleleft

$$\tau = \frac{Tc}{J} = \frac{2T}{\pi c^3} = \frac{2(4.0 \times 10^3)}{\pi(0.027)^3} = 129.4 \times 10^6 \text{ Pa} = 129.4 \text{ MPa} \quad \blacktriangleleft$$

(b) $T = 5.0 \times 10^3 \text{ N}\cdot\text{m} > T_y$ plastic region with elastic core.

The maximum shearing stress is $\tau_{max} = \tau_y = 145 \text{ MPa}$ \blacktriangleleft

$$T = \frac{4}{3}T_y \left(1 - \frac{\rho_y^3}{c^3}\right)$$

$$\frac{\rho_y^3}{c^3} = 4 - \frac{3T}{T_y} = 4 - \frac{(3)(5 \times 10^3)}{4.488 \times 10^3} = 0.6540 \quad \frac{\rho_y}{c} = 0.8680$$

$$\rho_y = 0.8680 c = (0.8680)(0.027) = 0.02344 \text{ m} = 23.4 \text{ mm} \quad \blacktriangleleft$$

PROBLEM 3.95

3.95 A 1.5-in.-diameter solid shaft is made of mild steel which is assumed to be elastoplastic with $\tau_y = 21$ ksi. Determine the maximum shearing stress and the radius of the elastic core caused by the application of a torque of magnitude (a) 12 kip·in., (b) 18 kip·in.

SOLUTION

$$c = \frac{1}{2}d = 0.75 \text{ in} \quad \tau_y = 21 \text{ ksi}$$

Compute T_y $T_y = \frac{J}{c}\tau_y = \frac{\pi}{2}c^3\tau_y = \frac{\pi}{2}(0.75)^3(21) = 13.916 \text{ kip}\cdot\text{in}$

(a) $T = 12 \text{ kip}\cdot\text{in} < T_y$ elastic $\rho = c = 0.75 \text{ in.}$ \blacktriangleleft

$$\tau = \frac{Tc}{J} = \frac{2T}{\pi c^3} = \frac{(2)(12)}{\pi(0.75)^3} = 18.11 \text{ ksi} \quad \blacktriangleleft$$

(b) $T = 18 \text{ kip}\cdot\text{in} > T_y$ plastic region with elastic core

The maximum shearing stress is $\tau_{max} = \tau_y = 21 \text{ ksi}$ \blacktriangleleft

$$T = \frac{4}{3}T_y \left(1 - \frac{\rho_y^3}{c^3}\right)$$

$$\frac{\rho_y^3}{c^3} = 4 - \frac{3T}{T_y} = 4 - \frac{(3)(18)}{13.916} = 0.11957 \quad \frac{\rho_y}{c} = 0.49265$$

$$\rho_y = 0.49265 c = (0.49265)(0.75) = 0.369 \text{ in.} \quad \blacktriangleleft$$

PROBLEM 3.96

3.96 A 30-mm-diameter solid rod is made of an elastoplastic material with $\tau_y = 3.5$ MPa. Knowing that the elastic core of the rod is 25 mm in diameter, determine the magnitude of the torque applied to the rod.

SOLUTION

$$\tau_y = 3.5 \times 10^6 \text{ Pa} \quad c = \frac{1}{2}d = 0.015 \text{ m} \quad \rho_y = \frac{1}{2}d_y = 0.0125 \text{ m}$$

$$T_y = \frac{J\tau_y}{c} = \frac{\pi}{2}c^3\tau_y = \frac{\pi}{2}(0.015)^3(3.5 \times 10^6) = 18.555 \text{ N}\cdot\text{m}$$

$$\frac{\rho_y}{c} = \frac{0.0125}{0.015} = 0.83333$$

$$T = \frac{4}{3}T_y \left(1 - \frac{1}{4}\left(\frac{\rho_y}{c}\right)^3\right) = \frac{4}{3}(18.555) \left[1 - \frac{1}{4}(0.83333)^3\right] = 21.2 \text{ N}\cdot\text{m} \quad \blacktriangleleft$$

PROBLEM 3.97

3.97 It is observed that a straightened steel paper clip can be twisted through several revolutions by the application of a torque of approximately 0.8 lb·in. Knowing that the diameter of the wire used to form the paper clip is 0.04 in., determine the approximate value of the yield stress of the steel.

SOLUTION

$$c = \frac{1}{2}d = 0.02 \text{ in.} \quad T_p = 0.8 \text{ lb}\cdot\text{in}$$

$$T_p = \frac{4}{3}T_y = \frac{4}{3}\frac{J\tau_y}{c} = \frac{4}{3}\frac{\pi}{2}c^3\tau_y = \frac{2\pi}{3}c^3\tau_y$$

$$\tau_y = \frac{3T_p}{2\pi c^3} = \frac{(3)(0.8)}{2\pi(0.02)^3} = 47.7 \text{ ksi} \quad \blacktriangleleft$$

PROBLEM 3.98

3.98 The solid circular shaft shown is made of a steel which is assumed to be elastoplastic with $\tau_y = 21$ ksi. Determine the magnitude T of the applied torque when the plastic zone is (a) 0.6 in. deep, (b) 1 in. deep.

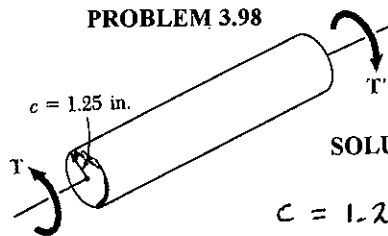

SOLUTION

$$c = 1.25 \text{ in} \quad \tau_y = 21 \text{ ksi}$$

$$T_y = \frac{J\tau_y}{c} = \frac{\pi}{2}c^3\tau_y = \frac{\pi}{2}(1.25)^3(21) = 64.427 \text{ kip}\cdot\text{in}$$

(a) $t_y = 0.6 \text{ in.}, \rho_y = c - t_y = 1.25 - 0.60 = 0.65 \text{ in.}, \frac{\rho_y}{c} = \frac{0.65}{1.25} = 0.520$

$$T = \frac{4}{3}T_y \left(1 - \frac{1}{4}\left(\frac{\rho_y}{c}\right)^3\right) = \frac{4}{3}(64.427) \left[1 - \frac{1}{4}(0.520)^3\right] = 82.9 \text{ kip}\cdot\text{in} \quad \blacktriangleleft$$

(b) $t_y = 1.0 \text{ in.}, \rho_y = c - t_y = 1.25 - 1.0 = 0.25 \text{ in.}, \frac{\rho_y}{c} = \frac{0.25}{1.25} = 0.200$

$$T = \frac{4}{3}T_y \left(1 - \frac{1}{4}\left(\frac{\rho_y}{c}\right)^3\right) = \frac{4}{3}(64.427) \left[1 - \frac{1}{4}(0.200)^3\right] = 85.7 \text{ kip}\cdot\text{in} \quad \blacktriangleleft$$

PROBLEM 3.99

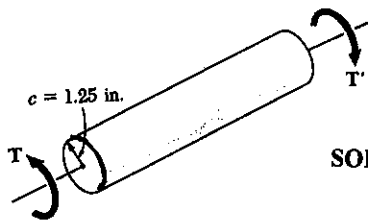

3.98 The solid circular shaft shown is made of a steel which is assumed to be elastoplastic with $\tau_y = 21$ ksi. Determine the magnitude T of the applied torque when the plastic zone is (a) 0.6 in. deep, (b) 1 in. deep.

3.99 For the shaft and loading of Prob. 3.98, determine the angle of twist in a 4-ft length of shaft.

SOLUTION

$$C = 1.25 \text{ in}, \quad \tau_y = 21 \text{ ksi} = 21 \times 10^3 \text{ psi}, \quad G = 11.2 \times 10^6 \text{ psi}$$

$$L = 4 \text{ ft} = 48 \text{ in}$$

$$\gamma = \frac{\rho r}{L} \quad \gamma_r = \frac{C \phi_r}{L} \quad \therefore \phi_r = \frac{L \gamma_r}{C} = \frac{L \tau_r}{C G} = \frac{(48)(21 \times 10^3)}{(1.25)(11.2 \times 10^6)} = 72.00 \times 10^{-3} \text{ rad}$$

$$\frac{\rho_r}{C} = \frac{\phi_r}{\phi} \quad \therefore \phi = \frac{C}{\rho_r} \phi_r$$

$$(a) \quad t_r = 0.6 \text{ in} \quad \rho_r = C - t_r = 1.25 - 0.6 = 0.65 \quad \frac{\rho_r}{C} = \frac{0.65}{1.25} = 0.520$$

$$\phi = \frac{\phi_r}{\rho_r/C} = \frac{72.00 \times 10^{-3}}{0.520} = 138.46 \times 10^{-3} \text{ rad} = 7.93^\circ$$

$$(b) \quad t_r = 1.0 \text{ in} \quad \rho_r = C - t_r = 1.25 - 1.0 = 0.25 \quad \frac{\rho_r}{C} = \frac{0.25}{1.25} = 0.200$$

$$\phi = \frac{\phi_r}{\rho_r/C} = \frac{72.00 \times 10^{-3}}{0.20} = 360 \times 10^{-3} \text{ rad} = 20.6^\circ$$

PROBLEM 3.100

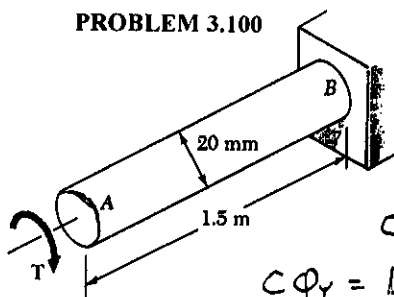

3.100 A torque T is applied to the 20-mm-diameter steel rod AB . Assuming the steel to be elastoplastic with $G = 77$ GPa and $\tau_y = 145$ MPa, determine (a) the torque T when the angle of twist at A is 25° , (b) the corresponding diameter of the elastic core of the shaft.

SOLUTION

$$C = \frac{1}{2} d = 0.010 \text{ m}, \quad L = 1.5 \text{ m}, \quad G = 77 \times 10^9 \text{ Pa}$$

$$C \phi_r = L \gamma_r = \frac{L \tau_r}{G} \quad \phi_r = \frac{L \tau_r}{G C}$$

$$\phi_r = \frac{(1.5)(145 \times 10^6)}{(77 \times 10^9)(0.010)} = 282.47 \times 10^{-3} \text{ rad}$$

$$T_r = \frac{J \tau_r}{C} = \frac{\pi}{2} C^3 \tau_r = \frac{\pi}{2} (0.010)^3 (145 \times 10^6) = 227.77 \text{ N}\cdot\text{m}$$

$$\phi = 25^\circ = 436.33 \times 10^{-3} \text{ rad} > \phi_r \quad \frac{\phi_r}{\phi} = \frac{282.47 \times 10^{-3}}{436.33 \times 10^{-3}} = 0.64737$$

$$(a) \quad T = \frac{4}{3} T_r \left(1 - \frac{1}{4} \left(\frac{\phi_r}{\phi}\right)^3\right) = \frac{4}{3} (227.77) \left[1 - \frac{1}{4} (0.64737)^3\right] = 283 \text{ N}\cdot\text{m}$$

$$(b) \quad \frac{\rho_r}{C} = \frac{\phi_r}{\phi} = 0.64737 \quad \rho_r = 0.64737 C = (0.64737)(0.010)$$

$$\rho_r = 6.4737 \times 10^{-3} \text{ m} = 6.4737 \text{ mm} \quad d_r = 2 \rho_r = 12.95 \text{ mm}$$

PROBLEM 3.101

3.101 A 18-mm-diameter solid circular shaft is made of a material which is assumed to be elastoplastic with $G = 77 \text{ GPa}$ and $\tau_y = 145 \text{ MPa}$. For a 1.2-m length, determine the maximum shearing stress and the angle of twist caused by a 200 N·m torque.

SOLUTION

$$\tau_y = 145 \times 10^6 \text{ Pa}, \quad c = \frac{1}{2}d = 0.009 \text{ m}, \quad L = 1.2 \text{ m}, \quad T = 200 \text{ N}\cdot\text{m}$$

$$T_y = \frac{J\tau_y}{c} = \frac{\pi}{2}c^3\tau_y = \frac{\pi}{2}(0.009)^3(145 \times 10^6) = 166.04 \text{ N}\cdot\text{m}$$

$$T > T_y \quad \text{plastic region with elastic core} \quad \tau_{\max} = \tau_y = 145 \text{ MPa} \quad \blacktriangleleft$$

$$\phi_y = \frac{T_y L}{GJ} = \frac{2T_y L}{\pi C^4 G} = \frac{(2)(166.04)(1.2)}{\pi(0.009)^4(77 \times 10^9)} = 251.08 \times 10^{-3} \text{ rad.}$$

$$T = \frac{4}{3}T_y \left(1 - \frac{1}{4}\frac{\phi^3}{\phi_y^3}\right)$$

$$\left(\frac{\phi_y}{\phi}\right)^3 = 4 - \frac{3T}{T_y} = 4 - \frac{(3)(200)}{166.04} = 0.38641 \quad \frac{\phi_y}{\phi} = 0.72837$$

$$\phi = \frac{\phi_y}{0.72837} = \frac{251.08 \times 10^{-3}}{0.72837} = 344.7 \times 10^{-3} \text{ rad} = 19.75^\circ \quad \blacktriangleleft$$

PROBLEM 3.102

3.102 A solid circular rod is made of a material which is assumed to be elastoplastic. Denoting by τ_y and ϕ_y respectively, the torque and angle of twist at the onset of yield, determine the angle of twist if the torque is increased to (a) $T = 1.1 T_y$, (b) $T = 1.25 T_y$, (c) $T = 1.3 T_y$.

SOLUTION

$$T = \frac{4}{3}T_y \left(1 - \frac{1}{4}\frac{\phi^3}{\phi_y^3}\right)$$

$$\frac{\phi_y}{\phi} = \sqrt[3]{4 - \frac{3T}{T_y}} \quad \text{or} \quad \frac{\phi}{\phi_y} = \frac{1}{\sqrt[3]{4 - \frac{3T}{T_y}}}$$

$$(a) \quad \frac{T}{T_y} = 1.10 \quad \frac{\phi}{\phi_y} = \frac{1}{\sqrt[3]{4 - (3)(1.10)}} = 1.126 \quad \phi = 1.126 \phi_y \quad \blacktriangleleft$$

$$(b) \quad \frac{T}{T_y} = 1.25 \quad \frac{\phi}{\phi_y} = \frac{1}{\sqrt[3]{4 - (3)(1.25)}} = 1.587 \quad \phi = 1.587 \phi_y \quad \blacktriangleleft$$

$$(c) \quad \frac{T}{T_y} = 1.3 \quad \frac{\phi}{\phi_y} = \frac{1}{\sqrt[3]{4 - (3)(1.3)}} = 2.15 \quad \phi = 2.15 \phi_y \quad \blacktriangleleft$$

PROBLEM 3.103

3.103 A 0.75-in.-diameter solid circular shaft is made of a material which is assumed to be elastoplastic with $G = 11.2 \times 10^6$ psi and $\tau_y = 21$ ksi. For a 5-ft length of the shaft, determine the maximum shearing stress and the angle of twist caused by a 2-kip-in. torque.

SOLUTION

$$c = \frac{1}{2}d = 0.375 \text{ in.}, \quad G = 11.2 \times 10^6 \text{ psi}, \quad \tau_y = 21 \text{ ksi} = 21000 \text{ psi}$$

$$L = 5 \text{ ft.} = 60 \text{ in.} \quad T = 2 \text{ kip-in} = 2 \times 10^3 \text{ lb-in}$$

$$T_Y = \frac{J\tau_y}{c} = \frac{\pi}{2}c^3\tau_y = \frac{\pi}{2}(0.375)^3(21000) = 1.7395 \times 10^3 \text{ lb-in.}$$

$$T > T_Y \quad \text{plastic region with elastic core} \therefore \tau_{\max} = \tau_y = 21 \text{ ksi}$$

$$\tau_y = \frac{c\phi_y}{L} \therefore \phi_y = \frac{L\tau_y}{c} = \frac{L\tau_y}{cG} = \frac{(60)(21000)}{(0.375)(11.2 \times 10^6)} = 300 \times 10^{-3} \text{ rad}$$

$$T = T_Y \left(1 - \frac{\phi^3}{\phi_y^3}\right) =$$

$$\frac{\phi}{\phi_y} = \frac{1}{\sqrt[3]{4 - \frac{3T}{T_Y}}} = \frac{1}{\sqrt[3]{4 - \frac{(3)(2 \times 10^3)}{1.7395 \times 10^3}}} = 1.220$$

$$\phi = 1.220 \phi_y = (1.220)(300 \times 10^{-3}) = 366 \times 10^{-3} \text{ rad} = 21.0^\circ$$

Www.iepnu.ir



PROBLEM 3.104

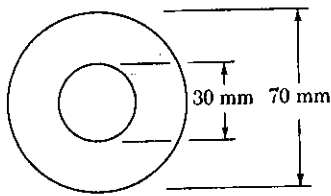

3.104 A hollow steel shaft is 0.9 m long and has the cross section shown. The steel is assumed to be elastoplastic with $\tau_y = 180$ MPa and $G = 77$ GPa. Determine the applied torque and the corresponding angle of twist (a) at the onset of yield, (b) when the plastic zone is 10 mm deep.

SOLUTION

(a) At the onset of yield, the stress distribution is the elastic distribution with $\tau_{max} = \tau_y$

$$c_2 = \frac{1}{2}d_2 = 0.035 \text{ m}, \quad c_1 = \frac{1}{2}d_1 = 0.015 \text{ m}.$$

$$J = \frac{\pi}{2}(c_2^4 - c_1^4) = \frac{\pi}{2}(0.035^4 - 0.015^4) = 2.2777 \times 10^{-6} \text{ m}^4$$

$$\tau_{max} = \tau_y = \frac{T_y c_2}{J} \quad \therefore T_y = \frac{J \tau_y}{c_2} = \frac{(2.2777 \times 10^{-6})(180 \times 10^6)}{0.035} = 11.714 \times 10^3 \text{ N}\cdot\text{m}$$

$$= 11.71 \text{ kN}\cdot\text{m} \quad \blacktriangleleft$$

$$\phi_y = \frac{T_y L}{GJ} = \frac{(11.714 \times 10^3)(0.9)}{(77 \times 10^9)(2.2777 \times 10^{-6})} = 60.11 \times 10^{-3} \text{ rad} = 3.44^\circ \quad \blacktriangleleft$$

(b) $t = 0.010 \text{ m} \quad p_r = c_2 - t = 0.035 - 0.010 = 0.025 \text{ m}$

$$\gamma = \frac{\rho \phi}{L} = \frac{p_r \phi}{L} = \tau_y = \frac{\tau_y}{G}$$

$$\phi = \frac{\tau_y L}{G p_r} = \frac{(180 \times 10^6)(0.9)}{(77 \times 10^9)(0.025)} = 84.156 \times 10^{-3} \text{ rad} = 4.82^\circ \quad \blacktriangleleft$$

Torque T_1 carried by elastic portion $c_1 \leq \rho \leq p_r$

$$\tau = \tau_y \text{ at } \rho = p_r. \quad \tau_y = \frac{T_1 p_r}{J_1} \quad \text{where } J_1 = \frac{\pi}{2}(p_r^4 - c_1^4)$$

$$J_1 = \frac{\pi}{2}(0.025^4 - 0.015^4) = 534.07 \times 10^{-9} \text{ m}^4$$

$$T_1 = \frac{J_1 \tau_y}{p_r} = \frac{(534.07 \times 10^{-9})(180 \times 10^6)}{0.025} = 3.845 \times 10^3 \text{ N}\cdot\text{m}$$

Torque T_2 carried by plastic portion

$$T_2 = 2\pi \int_{p_r}^{c_2} \tau_y \rho^2 d\rho = 2\pi \tau_y \left. \frac{\rho^3}{3} \right|_{p_r}^{c_2} = \frac{2\pi}{3} \tau_y (c_2^3 - p_r^3)$$

$$= \frac{2\pi}{3} (180 \times 10^6)(0.035^3 - 0.025^3) = 10.273 \times 10^3 \text{ N}\cdot\text{m}$$

Total torque

$$T = T_1 + T_2 = 3.845 \times 10^3 + 10.273 \times 10^3 = 14.12 \times 10^3 \text{ N}\cdot\text{m}$$

$$14.12 \text{ kN}\cdot\text{m} \quad \blacktriangleleft$$

PROBLEM 3.105

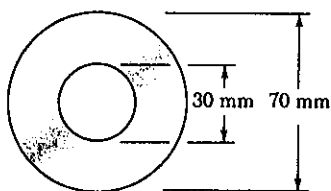

3.105 A hollow steel shaft is 0.9 m long and has the cross section shown. The steel is assumed to be elastoplastic with $\tau_y = 180$ MPa and $G = 77$ GPa. Determine (a) the angle of twist at which the section first becomes fully plastic, (b) the corresponding magnitude of the applied torque.

SOLUTION

$$c_1 = \frac{1}{2} d_1 = 0.015 \text{ m} \quad c_2 = \frac{1}{2} d_2 = 0.035 \text{ m}$$

(a) For onset of fully plastic yielding, $\rho_r = c_1$

$$\tau = \tau_y \therefore \gamma = \frac{\tau_y}{G} = \frac{\rho_r \Phi}{L} = \frac{c_1 \Phi}{L}$$

$$\Phi = \frac{L \tau_y}{c_1 G} = \frac{(0.9)(180 \times 10^6)}{(0.015)(77 \times 10^9)} = 140.26 \times 10^{-3} \text{ rad} = 8.04^\circ$$

$$\begin{aligned} (b) \quad T_p &= 2\pi \int_{c_1}^{c_2} \tau_y \rho^2 d\rho = 2\pi \tau_y \left. \frac{\rho^3}{3} \right|_{c_1}^{c_2} = \frac{2\pi}{3} \tau_y (c_2^3 - c_1^3) \\ &= \frac{2\pi}{3} (180 \times 10^6) (0.035^3 - 0.015^3) = 14.89 \times 10^3 \text{ N}\cdot\text{m} \\ &= 14.89 \text{ kN}\cdot\text{m} \end{aligned}$$

PROBLEM 3.106

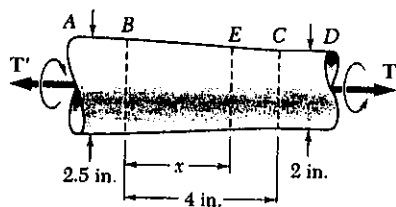

3.106 A shaft of mild steel is machined to the shape shown and then twisted by torques of magnitude 45 kip·in. Assuming the steel to be elastoplastic with $\tau_y = 21$ ksi, determine (a) the thickness of the plastic zone in portion CD of the shaft, (b) the length of the portion BE which remains fully elastic.

SOLUTION

(a) In portion CD $c = \frac{1}{2} d = 1.00$ in

$$T_Y = \frac{J_{CD} \tau_y}{c} = \frac{\pi c^3 \tau_y}{2} = \frac{\pi (1.00)^3 (21)}{2} = 32.987 \text{ kip}\cdot\text{in}$$

$$T = \frac{4}{3} T_Y \left(1 - \frac{\rho_r^3}{c^3}\right) \therefore \frac{\rho_r^3}{c^3} = 4 - \frac{3T}{T_Y} = 4 - \frac{(3)(40)}{32.987} = 0.36620$$

$$\frac{\rho_r}{c} = 0.71283, \quad \rho_r = (0.71283)(1.00) = 0.713 \text{ in}, \quad t_y = c - \rho_r = 0.287 \text{ in}$$

(b) For yielding at point E $\tau = \tau_y, c = c_E, T = 40$ kip·in

$$\tau_y = \frac{T c_E}{J_E} = \frac{2T}{\pi c_E^3} \therefore c_E^3 = \frac{2T}{\pi \tau_y} = \frac{(2)(40)}{\pi (21)} = 1.2126 \text{ in}^3$$

$$c_E = 1.0664 \text{ in.}$$

Using proportions from the sketch

$$\frac{1.25 - 1.0664}{1.25 - 1.00} = \frac{x}{4}$$

$$x = 2.94 \text{ in}$$

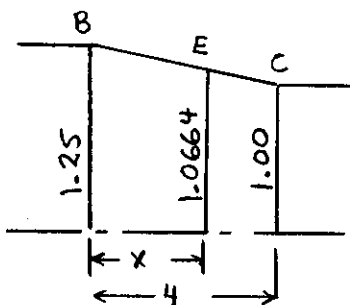

PROBLEM 3.107

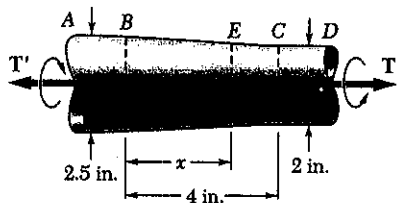

3.107 The magnitude of the torque T applied to the tapered shaft of Prob. 3.106 is slowly increased. Determine (a) the largest torque which may be applied to the shaft, (b) the length of portion BE which remains fully elastic.

SOLUTION

(a) The largest torque which may be applied to the shaft makes portion CD fully plastic.

In portion CD $c = \frac{1}{2}d = 1.00$ in.

$$T_Y = \frac{J \tau_Y}{c} = \frac{\pi}{2} c^3 \tau_Y = \frac{\pi}{2} (1.00)^3 (21) = 32.987 \text{ kip}\cdot\text{in.}$$

For fully plastic shaft $p_r = 0$

$$T = \frac{4}{3} T_Y \left(1 - \frac{p_r^3}{c^3}\right) = \frac{4}{3} T_Y = \frac{4}{3} (32.987) = 43.982 \text{ kip}\cdot\text{in.} \approx 44.0 \text{ kip}\cdot\text{in.}$$

(b) For yielding at point E , $\tau = \tau_Y$, $c = c_E$, $T = 43.982$ kip-in.

$$\tau_Y = \frac{T c_E}{J_E} = \frac{2T}{\pi c_E^3}, \quad c_E^3 = \frac{2T}{\pi \tau_Y} = \frac{(2)(43.982)}{\pi (21)} = 1.33333 \text{ in}^3$$

$$c_E = 1.1006 \text{ in}$$

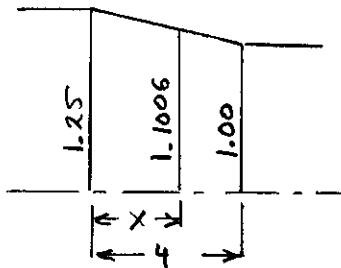

Using proportions from the sketch

$$\frac{1.25 - 1.1006}{1.25 - 1.00} = \frac{x}{4}$$

$$x = 2.39 \text{ in}$$

PROBLEM 3.108

3.108 Considering the partially plastic shaft of Fig. 3.38c, derive Eq. (3.32) by recalling that the integral in Eq. (3.26) represents the second moment about the r axis of the area under the τ - ρ curve.

SOLUTION

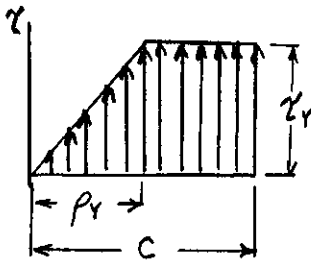

The stress is that shown on the left.

$$T = 2\pi \int_0^c \rho^2 \tau d\rho = 2\pi \int \rho^2 dA = 2\pi I$$

where $dA = \tau d\rho$ and $I = 2\text{nd moment about the } \tau\text{-axis.}$

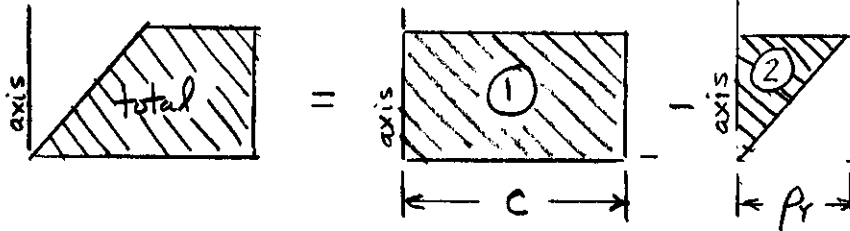

$$I = I_1 - I_2$$

$$= \frac{1}{3} \tau_y c^3 - \left\{ \frac{1}{3c} \tau_y \rho_y^3 + \frac{1}{2} \tau_y \rho_y \left(\frac{1}{3} \rho_y \right)^2 \right\}$$

$$= \frac{1}{3} \tau_y c^3 - \frac{1}{12} \tau_y \rho_y^3 = \frac{1}{3} \tau_y c^3 \left(1 - \frac{1}{4} \frac{\rho_y^3}{c^3} \right)$$

$$T = 2\pi I = \frac{2\pi}{3} \tau_y c^3 \left(1 - \frac{1}{4} \frac{\rho_y^3}{c^3} \right)$$

Recall that $T_y = \frac{J \tau_y}{c} = \frac{\pi}{2} c^3 \tau_y \quad \therefore \quad \frac{2\pi}{3} \tau_y c^3 = \frac{4}{3} T_y$

Hence $T = \frac{4}{3} T_y \left(1 - \frac{1}{4} \frac{\rho_y^3}{c^3} \right)$

PROBLEM 3.109

3.109 Using the stress-strain diagram shown, determine (a) the torque which causes a maximum shearing stress of 15 ksi in a 0.8-diameter solid rod, (b) the corresponding angle of twist in a 20-in. length of the rod.

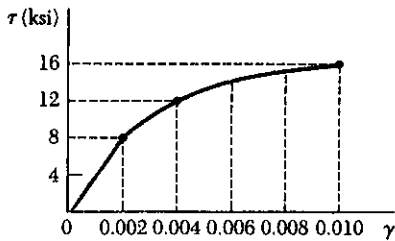

SOLUTION

(a) $\tau_{max} = 15 \text{ ksi}$ $c = \frac{1}{2}d = 0.400 \text{ in}$
 From the stress-strain diagram $\gamma_{max} = 0.008$

Let $z = \frac{r}{\gamma_{max}} = \frac{\rho}{c}$

$$T = 2\pi \int_0^c \rho^2 \tau d\rho = 2\pi c^3 \int_0^1 z^2 \tau dz = 2\pi c^3 I$$

where the integral I is given by $I = \int_0^1 z^2 \tau dz$

Evaluate I using a method of numerical integration. If Simpson's rule is used, the integration formula is

$$I = \frac{\Delta z}{3} \sum w z^2 \tau$$

where w is a weighting factor. Using $\Delta z = 0.25$, we get the values given in the table below.

z	γ	τ, ksi	$z^2 \tau, \text{ksi}$	w	$wz^2 \tau, \text{ksi}$
0	0.000	0	0.000	1	0.00
0.25	0.002	8	0.500	4	2.00
0.5	0.004	12	3.000	2	6.00
0.75	0.006	14	7.875	4	31.50
1.0	0.008	15	15.000	1	15.00
					54.50 ← $\sum wz^2 \tau$

$$I = \frac{(0.25)(54.50)}{3} = 4.54 \text{ ksi}$$

(a) $T = 2\pi c^3 I = 2\pi (0.400)^3 (4.54) = 1.826 \text{ kip-in}$ ▶

(b) $\gamma_{max} = \frac{c\phi}{L}$

$$\phi = \frac{L\gamma_m}{c} = \frac{(20)(0.008)}{0.400} = 400 \times 10^{-3} \text{ rad} = 22.9^\circ$$
 ▶

Note: Answers may differ slightly due to differences of opinion in reading the stress-strain curve.

PROBLEM 3.110

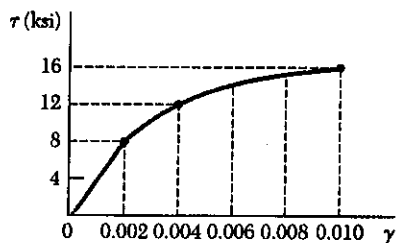

3.110 A hollow shaft of outer and inner diameters respectively equal to 0.6 in. and 0.2 in. is fabricated from an aluminum alloy for which the stress-strain diagram is given in the sketch. Determine the torque required to twist a 9-in. length of the shaft through 10° .

SOLUTION

$$\phi = 10^\circ = 174.53 \times 10^{-3} \text{ rad}$$

$$C_1 = \frac{1}{2}d_1 = 0.100 \text{ in.}, \quad C_2 = \frac{1}{2}d_2 = 0.300 \text{ in.}$$

$$\gamma_{\max} = \frac{C_2 \phi}{L} = \frac{(0.300)(174.53 \times 10^{-3})}{9} = 0.00582$$

$$\gamma_{\min} = \frac{C_1 \phi}{L} = \frac{(0.100)(174.53 \times 10^{-3})}{9} = 0.00194$$

Let $z = \frac{\gamma}{\gamma_{\max}} = \frac{\rho}{C_2}$ $z_1 = \frac{C_1}{C_2} = \frac{1}{3}$

$$T = 2\pi \int_{C_1}^{C_2} \rho^3 \tau d\rho = 2\pi C_2^3 \int_{z_1}^1 z^2 \tau dz = 2\pi C_2^3 I$$

where the integral I is given by $I = \int_{1/3}^1 z^2 \tau dz$

Evaluate I using a method of numerical integration. If Simpson's rule is used, the integration formula is

$$I = \frac{\Delta z}{3} \sum w z^2 \tau$$

where w is a weighting factor. Using $\Delta z = \frac{1}{6}$ we get the values given in the table below.

z	γ	τ , ksi	$z^2 \tau$, ksi	w	$w z^2 \tau$, ksi
1/3	0.00194	8.0	0.89	1	0.89
1/2	0.00291	10.0	2.50	4	10.00
2/3	0.00383	11.5	5.11	2	10.22
5/6	0.00485	13.0	9.03	4	36.11
1	0.00582	14.0	14.0	1	14.00

71.22 ← $\sum w z^2 \tau$

$$I = \frac{(1/6)(71.22)}{3} = 3.96 \text{ ksi}$$

$$T = 2\pi C_2^3 I = 2\pi (0.300)^3 (3.96) = 0.671 \text{ kip-in} = 671 \text{ lb-in} \blacktriangleleft$$

Note: Answer may differ slightly due to differences of opinion in reading the stress-strain curve.

PROBLEM 3.111

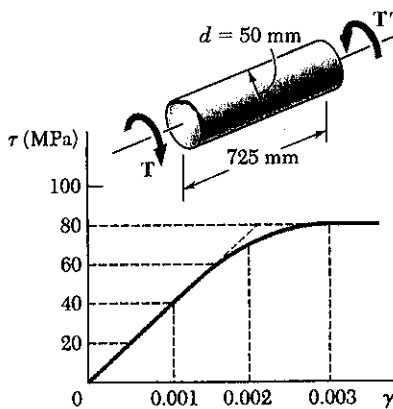

3.111 A 50-mm-diameter cylinder is made of a brass for which the stress-strain diagram is as shown. Knowing that the angle of twist is 5° in a 725-mm length, determine by approximate means the magnitude T of the torque applied to the shaft.

SOLUTION

$$\phi = 5^\circ = 87.266 \times 10^{-3} \text{ rad}$$

$$c = \frac{1}{2}d = 0.025 \text{ m}, \quad L = 0.725 \text{ m}$$

$$\gamma_{\max} = \frac{c\phi}{L} = \frac{(0.025)(87.266 \times 10^{-3})}{0.725} = 0.00301$$

$$\text{Let } z = \frac{r}{r_{\max}} = \frac{r}{c}$$

$$T = 2\pi \int_0^c \rho^2 \tau d\rho = 2\pi c^3 \int_0^1 z^2 \tau dz = 2\pi c^3 I$$

where the integral I is given by $I = \int_0^1 z^2 \tau dz$

Evaluate I using a method of numerical integration. If Simpson's rule is used, the integration formula is

$$I = \frac{\Delta z}{3} \sum w z^2 \tau$$

where w is a weighting factor. Using $\Delta z = 0.25$, we get the values given in the table below.

z	γ	τ, MPa	$z^2 \tau, \text{MPa}$	w	$wz^2 \tau, \text{MPa}$	
0	0	0	0	1	0	
0.25	0.00075	30	1.875	4	7.5	
0.5	0.0015	55	13.75	2	27.5	
0.75	0.00226	75	42.19	4	168.75	
1.0	0.00301	80	80.	1	80.	
					283.75	$\sum wz^2 \tau$

$$= 283.75 \times 10^6 \text{ Pa}$$

$$I = \frac{(0.25)(283.75 \times 10^6)}{3} = 23.65 \times 10^6 \text{ Pa}$$

$$T = 2\pi c^3 I = 2\pi (0.025)^3 (23.65 \times 10^6) = 2.32 \times 10^3 \text{ N}\cdot\text{m}$$

$$= 2.32 \text{ kN}\cdot\text{m}$$

PROBLEM 3.112

3.111 A 50-mm-diameter cylinder is made of a brass for which the stress-strain diagram is as shown. Knowing that the angle of twist is 5° in a 725-mm length, determine by approximate means the magnitude T of the torque applied to the shaft.

3.112 Three points on the nonlinear stress-strain diagram used in Prob. 3.111 are $(0,0)$, $(0.0015, 55\text{MPa})$, and $(0.003, 80\text{MPa})$. By fitting the polynomial $\tau = A + B\gamma + C\gamma^2$ through these points the following approximate relation has been obtained.

$$\tau = 46.7 \times 10^9 \gamma - 6.67 \times 10^{12} \gamma^2$$

Solve Prob. 3.111 using the relation, Eq. (3.2) and Eq. (3.26).

SOLUTION

$$\phi = 5^\circ = 87.266 \times 10^{-3} \text{ rad}, \quad c = \frac{1}{2}d = 0.025 \text{ m}, \quad L = 0.725 \text{ m}$$

$$\gamma_{\max} = \frac{c\phi}{L} = \frac{(0.025)(87.266 \times 10^{-3})}{0.725} = 3.009 \times 10^{-3}$$

$$\text{Let } z = \frac{\gamma}{\gamma_{\max}} = \frac{\rho}{c}$$

$$T = 2\pi \int_0^c \rho^2 \tau d\rho = 2\pi c^3 \int_0^1 z^2 \tau dz$$

The given stress strain curve is

$$\tau = A + B\gamma + C\gamma^2 = A + B\gamma_{\max} z + C\gamma_{\max}^2 z^2$$

$$\begin{aligned} T &= 2\pi c^3 \int_0^1 z^2 (A + B\gamma_{\max} z + C\gamma_{\max}^2 z^2) dz \\ &= 2\pi c^3 \left\{ A \int_0^1 z^2 dz + B\gamma_{\max} \int_0^1 z^3 dz + C\gamma_{\max}^2 \int_0^1 z^4 dz \right\} \\ &= 2\pi c^3 \left\{ \frac{1}{3}A + \frac{1}{4}B\gamma_{\max} + \frac{1}{5}C\gamma_{\max}^2 \right\} \end{aligned}$$

$$\text{Data: } A = 0, \quad B = 46.7 \times 10^9, \quad C = -6.67 \times 10^{12}$$

$$\frac{1}{3}A = 0, \quad \frac{1}{4}B\gamma_{\max} = \frac{1}{4}(46.7 \times 10^9)(3.009 \times 10^{-3}) = 35.13 \times 10^3$$

$$\frac{1}{5}C\gamma_{\max}^2 = -\frac{1}{5}(6.67 \times 10^{12})(3.009 \times 10^{-3})^2 = -12.08 \times 10^3$$

$$T = 2\pi(0.025)^3 \{ 0 + 35.13 \times 10^3 - 12.08 \times 10^3 \} = 2.26 \times 10^3 \text{ N}\cdot\text{m}$$

$$= 2.26 \text{ kN}\cdot\text{m} \quad \blacktriangleleft$$

PROBLEM 3.113

3.113 The solid circular drill rod AB is made of a steel which is assumed to be elastoplastic with $\tau_y = 160$ MPa and $G = 77$ GPa. Knowing that a torque $T = 5$ kN·m is applied to the rod and then removed, determine the maximum residual shearing stress in the rod.

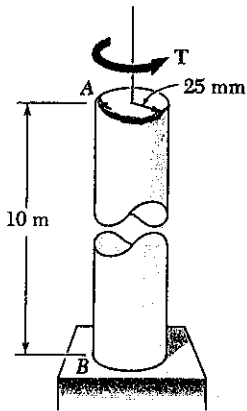

SOLUTION

$$c = 0.025 \text{ m}$$

$$J = \frac{\pi}{2} c^4 = \frac{\pi}{2} (0.025)^4 = 613.59 \times 10^{-9} \text{ m}^4$$

$$T_y = \frac{J \tau_y}{c} = \frac{\pi}{2} c^3 \tau_y = \frac{\pi}{2} (0.025)^3 (160 \times 10^6) = 3.927 \times 10^3 \text{ N}\cdot\text{m}$$

Loading: $T = 5 \times 10^3 \text{ N}\cdot\text{m}$

$$T = \frac{3}{8} T_y \left(1 - \frac{4}{3} \frac{\rho^3}{c^3}\right)$$

$$\frac{\rho^3}{c^3} = 4 - \frac{3T}{T_y} = 4 - \frac{(3)(5 \times 10^3)}{3.927 \times 10^3} = 0.18029$$

$$\frac{\rho_y}{c} = 0.5649, \quad \rho_y = 0.5649 c = 0.014123 \times 10^{-3} \text{ m} = 14.123 \text{ mm}$$

Unloading: $\tau' = \frac{T \rho}{J}$ where $T = 5 \times 10^3 \text{ kN}\cdot\text{m}$

At $\rho = c$ $\tau' = \frac{(5)(0.025)}{613.59 \times 10^{-9}} = 203.72 \times 10^6 \text{ Pa}$

At $\rho = \rho_y$ $\tau' = \frac{(5)(0.014123)}{613.59 \times 10^{-9}} = 115.08 \times 10^6 \text{ Pa}$

Residual: $\tau_{res} = \tau_{load} - \tau'$

At $\rho = c$ $\tau_{res} = 160 \times 10^6 - 203.72 \times 10^6 = -43.72 \times 10^6 \text{ Pa} = -43.7 \text{ MPa}$

At $\rho = \rho_y$ $\tau_{res} = 160 \times 10^6 - 115.08 \times 10^6 = 44.92 \times 10^6 \text{ Pa} = 44.9 \text{ MPa}$

PROBLEM 3.114

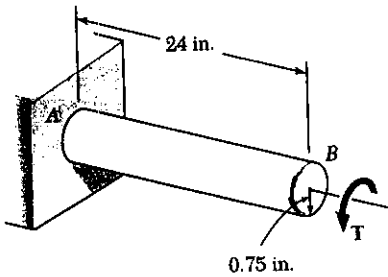

3.114 The solid circular shaft AB is made of a steel which is assumed to be elastoplastic with $G = 11.2 \times 10^6$ psi and $\tau_r = 21$ ksi. The torque T is increased until the radius of the elastic core is 0.25 in. Determine the maximum residual shearing stress in the shaft after the torque T has been removed.

SOLUTION

$$c = 0.75 \text{ in.} \quad \rho_r = 0.25 \text{ in.} \quad \frac{\rho_r}{c} = \frac{0.25}{0.75} = \frac{1}{3}$$

$$J = \frac{\pi}{2} c^4 = \frac{\pi}{2} (0.75)^4 = 0.49701 \text{ in}^4$$

$$T_r = \frac{J \tau_r}{c} = \frac{(0.49701)(21)}{0.75} = 13.916 \text{ kip-in.}$$

$$\begin{aligned} \text{At end of loading: } T &= \frac{4}{3} T_r \left(1 - \frac{1}{4} \left(\frac{\rho_r}{c}\right)^3\right) = \frac{4}{3} (13.916) \left[1 - \frac{1}{4} \left(\frac{1}{3}\right)^3\right] \\ &= 18.383 \text{ kip-in.} \end{aligned}$$

The stresses are

$$\begin{aligned} \gamma_{\text{load}} &= 0 \text{ at } \rho = 0 \\ \gamma_{\text{load}} &= \tau_r = 21 \text{ ksi at } \rho = 0.25 \text{ in} \\ \gamma_{\text{load}} &= \tau_r = 21 \text{ ksi at } \rho = 0.75 \text{ in.} \end{aligned}$$

Torque change during unloading $T = -18.383$ kip-in.

Stress changes during unloading $\gamma' = \frac{T \rho}{J}$ (elastic)

At $\rho = 0$ $\gamma' = 0$

At $\rho = 0.25$ in $\gamma' = \frac{(18.383)(0.25)}{0.49701} = 9.25$ ksi

At $\rho = 0.75$ in $\gamma' = \frac{(18.383)(0.75)}{0.49701} = 27.74$ ksi

Residual stresses are found by adding $\gamma_{\text{res}} = \gamma_{\text{load}} - \gamma'$

At $\rho = 0$ $\gamma_{\text{res}} = 0$

At $\rho = 0.25$ in $\gamma_{\text{res}} = 21 - 9.75 = 11.75$ ksi

At $\rho = 0.75$ in $\gamma_{\text{res}} = 21 - 27.74 = -6.74$ ksi

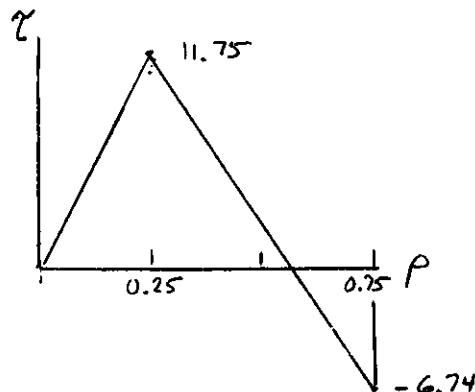

PROBLEM 3.115

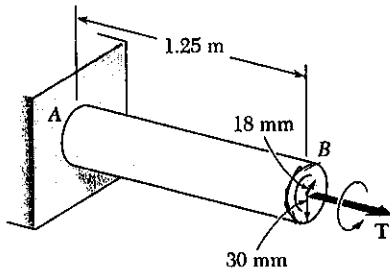

3.115 The hollow shaft AB is made of a steel which is assumed to be elastoplastic with $\tau_y = 145 \text{ MPa}$ and $G = 77 \text{ GPa}$. The magnitude T of the torque is slowly increased until the plastic zone first reaches the inner surface; the torque is then removed. Determine (a) the maximum residual shearing stress, (b) the permanent angle of twist of the shaft.

SOLUTION

inner radius $c_1 = 0.018 \text{ m}$, outer radius $c_2 = 0.030 \text{ m}$
 $J = \frac{\pi}{2}(c_2^4 - c_1^4) = \frac{\pi}{2}(0.030^4 - 0.018^4)$
 $= 1.10745 \times 10^{-6} \text{ m}^4$

Loading: When ρ_r reaches inner surface, then $\tau = \tau_y$

$$T_{\text{load}} = 2\pi \int_{c_1}^{c_2} \rho^2 \tau_y d\rho = 2\pi \tau_y \frac{\rho^3}{3} \Big|_{c_1}^{c_2} = \frac{2\pi}{3} \tau_y (c_2^3 - c_1^3)$$

$$= \frac{2\pi}{3} (145 \times 10^6) (0.030^3 - 0.018^3) = 6.4285 \times 10^3 \text{ N}\cdot\text{m}$$

$$\gamma = \frac{\tau_y}{G} \text{ at } \rho = c_1, \quad \text{Also } \gamma = \frac{\rho\phi}{L} \therefore \phi = \frac{L\gamma}{\rho} = \frac{L\tau_y}{c_1 G}$$

$$\phi_{\text{load}} = \frac{(1.25)(145 \times 10^6)}{(0.018)(77 \times 10^9)} = 130.77 \times 10^{-3} \text{ rad} = 7.493^\circ$$

Unloading: $T = 6.4285 \times 10^3 \text{ N}\cdot\text{m}$ (elastic) $\Delta\tau = \frac{\Delta T \rho}{J}$

$$\text{At } \rho = c_2 \quad \tau' = \frac{(6.4285)(0.030)}{1.10745 \times 10^{-6}} = 174.14 \times 10^6 \text{ Pa}$$

$$\text{At } \rho = c_1 \quad \tau' = \frac{(6.4285)(0.018)}{1.10745 \times 10^{-6}} = 104.49 \times 10^6 \text{ Pa}$$

$$\phi' = \frac{(LT)L}{GJ} = \frac{(6.4285)(1.25)}{(77 \times 10^9)(1.10745 \times 10^{-6})} = 94.23 \times 10^{-3} \text{ rad} = -5.399^\circ$$

Residual: $\tau_{\text{res}} = \tau_{\text{load}} - \tau'$ $\phi_{\text{perm}} = \phi_{\text{load}} - \phi'$

(a) At $\rho = c_2$ $\tau_{\text{res}} = 145 \times 10^6 - 174.14 \times 10^6 = -29.14 \times 10^6 \text{ Pa}$
 $= -29.1 \text{ MPa}$

At $\rho = c_1$ $\tau_{\text{res}} = 145 \times 10^6 - 104.49 \times 10^6 = 40.51 \times 10^6 \text{ Pa}$
 $= 40.5 \text{ MPa}$

(b) $\phi_{\text{perm}} = 130.77 \times 10^{-3} - 94.23 \times 10^{-3} = 36.54 \times 10^{-3} \text{ rad}$
 $= 2.09^\circ$

PROBLEM 3.116

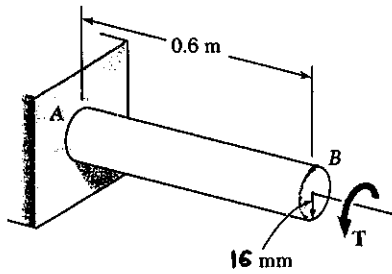

3.116 The solid shaft shown is made of a steel which is assumed to be elastoplastic with $\tau_y = 145 \text{ MPa}$ and $G = 77 \text{ GPa}$. The torque T is increased in magnitude until the shaft has been twisted through 6° and then removed. Determine (a) the magnitude and location of the maximum residual shearing stress, (b) the permanent angle of twist of the shaft.

SOLUTION

$$c = 0.016 \text{ m} \quad \phi = 6^\circ = 104.72 \times 10^{-3} \text{ rad}$$

$$\gamma_{\max} = \frac{c\phi}{L} = \frac{(0.016)(104.72 \times 10^{-3})}{0.6} = 0.0027925$$

$$\gamma_y = \frac{\tau_y}{G} = \frac{145 \times 10^6}{77 \times 10^9} = 0.0018831$$

$$\frac{p_y}{c} = \frac{\gamma_y}{\gamma_{\max}} = \frac{0.0018831}{0.0027925} = 0.67433$$

$$J = \frac{\pi}{2} c^4 = \frac{\pi}{2} (0.016)^4 = 102.944 \times 10^{-9} \text{ m}^4$$

$$T_y = \frac{J \tau_y}{c} = \frac{\pi}{2} c^3 \tau_y = \frac{\pi}{2} (0.016)^3 (145 \times 10^6) = 932.93 \text{ N}\cdot\text{m}$$

$$\begin{aligned} \text{At end of loading } T_{\text{load}} &= \frac{4}{3} T_y \left(1 - \frac{1}{4} \left(\frac{p_y}{c}\right)^3\right) = \frac{4}{3} (932.93) \left[1 - \frac{1}{4} (0.67433)^3\right] \\ &= 1.14855 \times 10^3 \text{ N}\cdot\text{m} \end{aligned}$$

Unloading: elastic $T' = -1.14855 \times 10^3 \text{ N}\cdot\text{m}$

$$\text{At } \rho = c \quad \tau' = \frac{T' c}{J} = \frac{(-1.14855 \times 10^3)(0.016)}{102.944 \times 10^{-9}} = 178.52 \times 10^6 \text{ Pa}$$

$$\text{At } \rho = p_y \quad \tau' = \frac{T' c}{J} \frac{p_y}{c} = (-178.52 \times 10^6)(0.67433) = 120.38 \times 10^6 \text{ Pa}$$

$$\phi' = \frac{T' L}{G J} = \frac{(-1.14855 \times 10^3)(0.6)}{(77 \times 10^9)(102.944 \times 10^{-9})} = 86.94 \times 10^{-3} \text{ rad} =$$

Residual: $\tau_{\text{res}} = \tau_{\text{load}} - \tau'$ $\phi_p = \phi_{\text{load}} - \phi'$

$$\begin{aligned} \text{At } \rho = c \quad \tau_{\text{res}} &= 145 \times 10^6 - 178.52 \times 10^6 = -33.52 \times 10^6 \text{ Pa} \\ &= -33.5 \text{ MPa} \end{aligned}$$

$$\begin{aligned} \text{At } \rho = p_y \quad \tau_{\text{res}} &= 145 \times 10^6 - 120.38 \times 10^6 = 24.62 \times 10^6 \text{ Pa} \\ &= 24.6 \text{ MPa} \end{aligned}$$

$$\phi_{\text{perm}} = 104.72 \times 10^{-3} - 86.94 \times 10^{-3} = 17.78 \times 10^{-3} \text{ rad} = 1.019^\circ$$

PROBLEM 3.117

3.113 The solid circular drill rod AB is made of a steel which is assumed to be elastoplastic with $\tau_y = 160 \text{ MPa}$ and $G = 77 \text{ GPa}$. Knowing that a torque $T = 5 \text{ kN}\cdot\text{m}$ is applied to the rod and then removed, determine the maximum residual shearing stress in the rod.

SOLUTION

3.117 In Prob. 3.113, determine the permanent angle of twist of the rod.

From the solution to PROBLEM 3.113

$$c = 0.025 \text{ m}, \quad J = 613.59 \times 10^{-9} \text{ m}^4, \quad \frac{r_y}{c} = 0.5649, \quad \rho_r = 0.014123 \text{ m}$$

After loading $\gamma = \frac{\rho\phi}{L} \therefore \phi = \frac{L\gamma}{\rho} = \frac{L\tau_r}{\rho_r G}$

$$\phi_{\text{load}} = \frac{(10)(160 \times 10^6)}{(0.014123)(77 \times 10^9)} = 1.4713 \text{ rad} = 84.30^\circ$$

During unloading $\phi' = \frac{TL}{GJ}$ (elastic) $\Delta T = 5 \times 10^3 \text{ N}\cdot\text{m}$

$$\phi' = \frac{(5 \times 10^3)(10)}{(77 \times 10^9)(613.59 \times 10^{-9})} = 1.0583 \text{ rad} = 60.64^\circ$$

Permanent twist angle

$$\phi_{\text{perm}} = \phi_{\text{load}} - \phi = 1.4713 - 1.0583 = 0.4130 \text{ rad} = 23.7^\circ \quad \blacktriangleleft$$

PROBLEM 3.118

3.114 The solid circular shaft AB is made of a steel which is assumed to be elastoplastic with $G = 11.2 \times 10^6 \text{ psi}$ and $\tau_y = 21 \text{ ksi}$. The torque T is increased until the radius of the elastic core is 0.25 in. Determine the maximum residual shearing stress in the shaft after the torque T has been removed.

SOLUTION

3.118 In Prob. 3.114, determine the permanent angle of twist of the shaft.

From the solution to PROBLEM 3.114, $c = 0.75 \text{ in}$, $J = 0.49701 \text{ in}^4$

After loading $T = 18.383 \text{ kip}\cdot\text{in}$, $\rho_r = 0.25 \text{ in}$, $\tau_r = 21 \text{ ksi}$

$$\gamma = \frac{\rho\phi}{L} \therefore \phi = \frac{L\gamma}{\rho} = \frac{L\tau_r}{\rho_r G}$$

where $L = 24 \text{ in}$, $\tau_r = 21 \text{ ksi}$, $G = 11.2 \times 10^6 \text{ psi} = 11.2 \times 10^3 \text{ ksi}$

$$\phi_{\text{load}} = \frac{(24)(21)}{(0.25)(11.2 \times 10^3)} = 180 \times 10^{-3} \text{ rad} = 10.31^\circ$$

Unloading $T = 18.383 \text{ kip}\cdot\text{in}$

$$\phi' = \frac{TL}{GJ} = \frac{(-18.383)(24)}{(11.2 \times 10^3)(0.49701)} = 79.26 \times 10^{-3} \text{ rad} = 4.54^\circ$$

Permanent angle of twist $\phi_{\text{perm}} = \phi_{\text{load}} - \phi'$

$$\phi_{\text{perm}} = 180 \times 10^{-3} - 79.26 \times 10^{-3} = 100.74 \times 10^{-3} \text{ rad} = 5.77^\circ \quad \blacktriangleleft$$

PROBLEM 3.119

3.119 A torque T applied to a solid rod made of an elastoplastic material is increased until the rod becomes fully plastic and then is removed. (a) Show that the distribution of residual stresses is as represented in the figure. (b) Determine the magnitude of the torque due to the stresses acting on the portion of the rod located within a circle of radius c_0 .

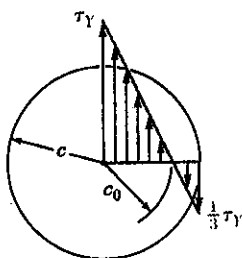

SOLUTION

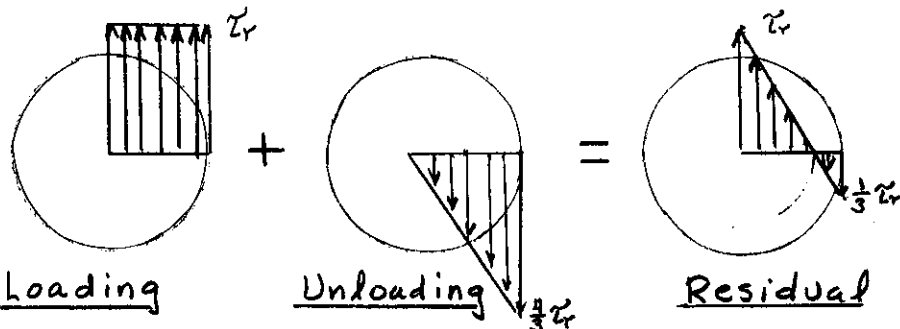

(a)

After loading $p_r = 0, T_{total} = \frac{4}{3} T_r = \frac{4}{3} \frac{\pi}{2} c^3 \tau_r = \frac{2\pi}{3} c^3 \tau_r$

Unloading $\tau' = \frac{Tc}{J} = \frac{2T_r}{\pi c^3} = \frac{2(T_{total})}{\pi c^3} = \frac{4}{3} \tau_r$ at $p = c$

$$\tau' = \frac{4}{3} \tau_r \frac{p}{c}$$

Residual $\tau_{res} = \tau_r - \frac{4}{3} \tau_r \frac{p}{c} = \tau_r \left(1 - \frac{4p}{3c}\right)$

To find c_0 set $\tau_{res} = 0$ and $p = c_0$

$$0 = 1 - \frac{4c_0}{3c} \quad \therefore c_0 = \frac{3}{4}c$$

(b) $T = 2\pi \int_0^{c_0} \rho^2 \tau d\rho = 2\pi \int_0^{\frac{3}{4}c} \rho^2 \tau_r \left(1 - \frac{4}{3} \frac{\rho}{c}\right) d\rho$
 $= 2\pi \tau_r \left(\frac{\rho^3}{3} - \frac{4}{3} \frac{\rho^4}{4c} \right) \Big|_0^{\frac{3}{4}c} = 2\pi \tau_r c^3 \left\{ \frac{1}{3} \left(\frac{3}{4}\right)^3 - \left(\frac{4}{3}\right) \frac{1}{4} \left(\frac{3}{4}\right)^4 \right\}$
 $= 2\pi \tau_r c^3 \left\{ \frac{9}{64} - \frac{27}{256} \right\} = \frac{9\pi}{128} \tau_r c^3 = 0.2209 \tau_r c^3$

PROBLEM 3.120

3.116 The solid shaft shown is made of a steel which is assumed to be elastoplastic with $\tau_y = 145 \text{ MPa}$ and $G = 77 \text{ GPa}$. The torque T is increased in magnitude until the shaft has been twisted through 6° and then removed. Determine (a) the magnitude and location of the maximum residual shearing stress, (b) the permanent angle of twist of the shaft.

3.120 After the solid shaft of Prob. 3.116 has been loaded and unloaded as described in that problem, a torque T_1 of sense opposite to the original torque T is applied to the shaft. Assuming no change in the value of ϕ_y , determine the angle of twist ϕ_1 for which yield is initiated in this second loading and compare it with the angle ϕ_y for which the shaft started to yield in the original loading.

SOLUTION

From the solution to **PROBLEM 3.116** $c = 0.016 \text{ m}$, $L = 0.6 \text{ m}$

$$\tau_y = 145 \times 10^6 \text{ Pa}, \quad J = 102.944 \times 10^{-9} \text{ m}^4$$

The residual stress at $\rho = c$ is $\tau_{res} = 33.5 \text{ MPa}$

For loading in the opposite sense, the change in stress to produce reversed yielding is

$$\tau_1 = \tau_y - \tau_{res} = 145 \times 10^6 - 33.5 \times 10^6 = 111.5 \times 10^6 \text{ Pa}$$

$$\tau_1 = \frac{T_1 c}{J} \quad \therefore \quad T_1 = \frac{J \tau_1}{c} = \frac{(102.944 \times 10^{-9})(111.5 \times 10^6)}{0.016}$$

$$= 717 \text{ N}\cdot\text{m}$$

Angle of twist

$$\phi_1 = \frac{T_1 L}{G J} = \frac{(717 \times 10^3)(0.6)}{(77 \times 10^9)(102.944 \times 10^{-9})} = 54.3 \times 10^{-3} \text{ rad}$$

$$= 3.11^\circ$$

PROBLEM 3.121

3.114 The solid circular shaft AB is made of a steel which is assumed to be elastoplastic with $G = 11.2 \times 10^6$ psi and $\tau_y = 21$ ksi. The torque T is increased until the radius of the elastic core is 0.25 in. Determine the maximum residual shearing stress in the shaft after the torque T has been removed.

3.121 After the solid shaft of Prob. 3.114 has been loaded and unloaded as described in that problem, a torque T_1 of sense opposite to the original torque T is applied to the shaft. Assuming no change in the value of τ_y , determine the magnitude T_1 of the torque T_1 required to initiate yield in this second loading and compare it with the magnitude T_y of the torque T which caused the shaft to yield in the original loading.

SOLUTION

From the solution to PROBLEM 3.114 $c = 0.75$ in, $L = 24$ in.

$$\tau_y = 21 \text{ ksi}, \quad J = 0.49701 \text{ in}^4$$

The residual stress at $\rho = c$ is $\tau_{res} = 6.74$ ksi

For loading in the opposite sense, the change in stress to produce reversed yielding is

$$\tau_1 = \tau_y - \tau_{res} = 21 - 6.74 = 14.26 \text{ ksi}$$

$$\tau_1 = \frac{T_1 c}{J} \quad \therefore \quad T_1 = \frac{J \tau_1}{c} = \frac{(0.49701)(14.26)}{0.75} = 9.45 \text{ kip-in.} \quad \blacktriangleleft$$

$$\therefore \quad T_y = \frac{J \tau_y}{c} = \frac{(0.49701)(21)}{0.75} = 13.92 \text{ kip-in.} \quad \blacktriangleleft$$

PROBLEM 3.122

3.122 Knowing that the magnitude of the torque T is 1800 lb·in., determine for each of the aluminum bars shown the maximum shearing stress and the angle of twist at end B . Use $G = 3.9 \times 10^6$ psi.

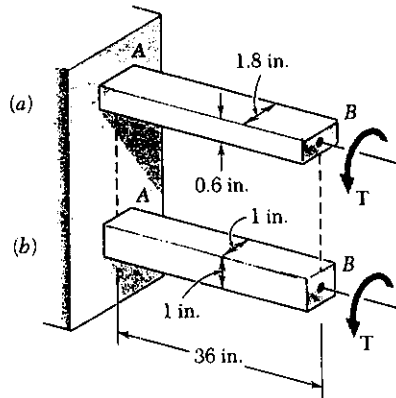

SOLUTION

$$T = 1800 \text{ lb}\cdot\text{in}, \quad L = 36 \text{ in}$$

$$(a) \quad a = 1.8 \text{ in}, \quad b = 0.6 \text{ in} \quad \frac{a}{b} = \frac{1.8}{0.6} = 3$$

$$\text{From Table 3.1} \quad C_1 = 0.267, \quad C_2 = 0.263$$

$$\tau_{\max} = \frac{T}{C_1 a b^2} = \frac{1800}{(0.267)(1.8)(0.6)^2}$$

$$= 10.40 \times 10^3 \text{ psi} = 10.40 \text{ ksi} \quad \blacktriangleleft$$

$$\phi = \frac{TL}{C_2 a b^3 G} = \frac{(1800)(36)}{(0.263)(1.8)(0.6)^3(3.9 \times 10^6)} = 162.5 \times 10^{-3} \text{ rad} = 9.31^\circ \quad \blacktriangleleft$$

$$(b) \quad a = 1.0 \text{ in}; \quad b = 1.0 \text{ in}, \quad \frac{a}{b} = 1.00, \quad C_1 = 0.208, \quad C_2 = 0.1406$$

$$\tau_{\max} = \frac{T}{C_1 a b^2} = \frac{1800}{(0.208)(1.0)(1.0)^2} = 8.65 \times 10^3 \text{ psi} = 8.65 \text{ ksi} \quad \blacktriangleleft$$

$$\phi = \frac{TL}{C_2 a b^3 G} = \frac{(1800)(36)}{(0.1406)(1.0)(1.0)^3(3.9 \times 10^6)} = 118.2 \times 10^{-3} \text{ rad} = 6.77^\circ \quad \blacktriangleleft$$

[Www.iepnu.ir](http://www.iepnu.ir)



PROBLEM 3.123

3.123 Using $\tau_{all} = 10$ ksi, determine for each of the aluminum bars shown the largest torque T which may be applied and the corresponding angle of twist. Use $G = 3.9 \times 10^6$ psi.

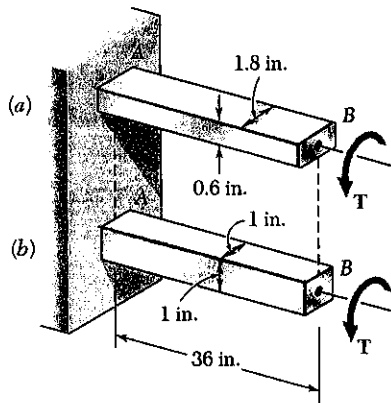

SOLUTION

$$\tau_{all} = 10 \text{ ksi}, \quad G = 3.9 \times 10^6 \text{ psi} = 3.9 \times 10^3 \text{ ksi}$$

$$(a) \quad a = 1.8 \text{ in.}, \quad b = 0.6 \text{ in.}, \quad \frac{a}{b} = \frac{1.8}{0.6} = 3$$

$$\text{From Table 3.1} \quad c_1 = 0.267, \quad c_2 = 0.263$$

$$\tau_{max} = \frac{T}{c_1 a b^2} \quad \therefore T = c_1 a b^2 \tau_{max}$$

$$T = (0.267)(1.8)(0.6)^2(10) = 1.730 \text{ kip}\cdot\text{in} \quad \blacktriangleleft$$

$$\phi = \frac{TL}{c_2 a b^3 G} = \frac{(1.730)(36)}{(0.263)(1.8)(0.6)^3(3.9 \times 10^3)} = 156.2 \times 10^{-3} \text{ rad}$$

$$= 8.95^\circ \quad \blacktriangleleft$$

$$(b) \quad a = 1.0 \text{ in.}, \quad b = 1.0 \text{ in.}, \quad \frac{a}{b} = 1.00 \quad c_1 = 0.208, \quad c_2 = 0.1406$$

$$T = c_1 a b^2 \tau_{max} = (0.208)(1.0)(1.0)^2(10) = 2.08 \text{ kip}\cdot\text{in} \quad \blacktriangleleft$$

$$\phi = \frac{TL}{c_2 a b^3 G} = \frac{(2.08)(36)}{(0.1406)(1.0)(1.0)^3(3.9 \times 10^3)} = 136.6 \times 10^{-3} \text{ rad}$$

$$= 7.82^\circ \quad \blacktriangleleft$$

PROBLEM 3.124

3.124 Knowing that $T = 800 \text{ N}\cdot\text{m}$, determine for each of the cold-rolled yellow brass bars shown the maximum shearing stress and the angle of twist at end B . Use $G = 39 \text{ GPa}$.

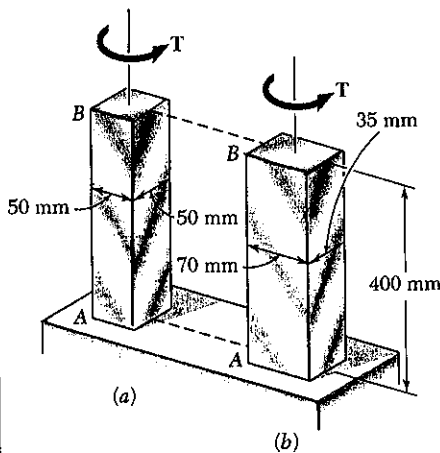

SOLUTION

$$T = 800 \text{ N}\cdot\text{m} \quad L = 400 \text{ mm} = 0.400 \text{ m}$$

$$G = 39 \times 10^9 \text{ Pa}$$

$$(a) \quad a = 50 \text{ mm} = 0.050 \text{ m}, \quad b = 50 \text{ mm} = 0.050 \text{ m}$$

$$\frac{a}{b} = \frac{50}{50} = 1.00$$

$$\text{From Table 3.1, } C_1 = 0.208, \quad C_2 = 0.1406$$

$$\tau_{\max} = \frac{T}{C_1 a b^2} = \frac{800}{(0.208)(0.050)(0.050)^2} = 30.8 \times 10^6 \text{ Pa} = 30.8 \text{ MPa} \quad \blacktriangleleft$$

$$\phi = \frac{TL}{C_2 a b^3 G} = \frac{(800)(0.400)}{(0.1406)(0.05)^3(39 \times 10^9)} = 9.33 \times 10^{-3} \text{ rad}$$

$$= 0.535^\circ \quad \blacktriangleleft$$

$$(b) \quad a = 70 \text{ mm} = 0.070 \text{ m}, \quad b = 35 \text{ mm} = 0.035 \text{ m}, \quad \frac{a}{b} = \frac{70}{35} = 2.0$$

$$C_1 = 0.246, \quad C_2 = 0.229$$

$$\tau_{\max} = \frac{T}{C_1 a b^2} = \frac{800}{(0.246)(0.070)(0.035)^2} = 37.9 \times 10^6 \text{ Pa} = 37.9 \text{ MPa} \quad \blacktriangleleft$$

$$\phi = \frac{TL}{C_2 a b^3 G} = \frac{(800)(0.400)}{(0.229)(0.070)(0.035)^3(39 \times 10^9)} = 11.94 \times 10^{-3} \text{ rad}$$

$$= 0.684^\circ \quad \blacktriangleleft$$

PROBLEM 3.125

3.125 Using $\tau_{all} = 50 \text{ MPa}$, determine for each of the cold-rolled yellow brass bars shown the largest torque T which may be applied and the corresponding angle of twist. Use $G = 39 \text{ GPa}$.

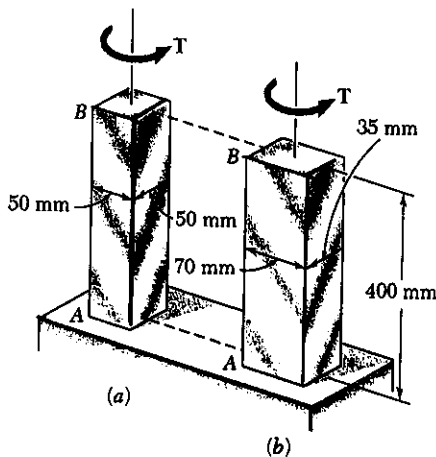

SOLUTION

$$\tau_{all} = 50 \times 10^6 \text{ Pa}, \quad L = 400 \text{ mm} = 0.400 \text{ m}$$

$$G = 39 \times 10^9 \text{ Pa}$$

$$(a) \quad a = 50 \text{ mm} = 0.050 \text{ m}, \quad b = 50 \text{ mm} = 0.050 \text{ m}$$

$$\frac{a}{b} = 1.00$$

$$\text{From Table 3.1} \quad c_1 = 0.208, \quad c_2 = 0.1406$$

$$\tau_{max} = \frac{T}{c_1 a b^2}$$

$$T = c_1 a b^2 \tau_{max} = (0.208)(0.050)(0.050)^2 (50 \times 10^6) = 1300 \text{ N}\cdot\text{m}$$

$$= 1.300 \text{ kN}\cdot\text{m} \quad \blacktriangleleft$$

$$\phi = \frac{TL}{c_2 a b^3 G} = \frac{(1300)(0.400)}{(0.1406)(0.050)(0.050)^3 (39 \times 10^9)} = 15.17 \times 10^{-3} \text{ rad}$$

$$= 0.869^\circ \quad \blacktriangleleft$$

$$(b) \quad a = 70 \text{ mm} = 0.070 \text{ m}, \quad b = 35 \text{ mm} = 0.035 \text{ m}, \quad \frac{a}{b} = \frac{70}{35} = 2.0$$

$$\text{From Table 3.1} \quad c_1 = 0.246, \quad c_2 = 0.229$$

$$T = c_1 a b^2 \tau_{max} = (0.246)(0.070)(0.035)^2 (50 \times 10^6) = 1055 \text{ N}\cdot\text{m}$$

$$= 1.055 \text{ kN}\cdot\text{m} \quad \blacktriangleleft$$

$$\phi = \frac{TL}{c_2 a b^3 G} = \frac{(1055)(0.400)}{(0.229)(0.070)(0.035)^3 (39 \times 10^9)} = 15.74 \times 10^{-3} \text{ rad}$$

$$= 0.902^\circ \quad \blacktriangleleft$$

PROBLEM 3.126

3.126 A 2-kip-in. torque T is applied to each of the steel bars shown. Knowing that $\tau_{all} = 6$ ksi, determine the required dimension b for each bar.

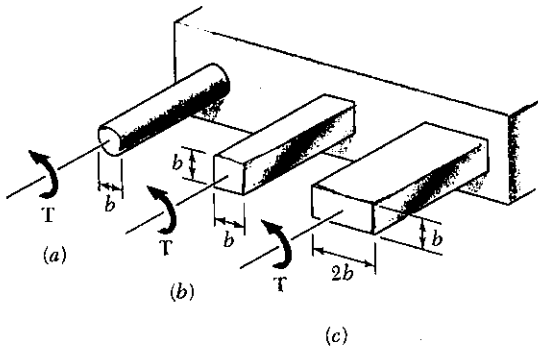

SOLUTION

$$T = 2 \text{ kip-in} \quad \tau_{max} = 6 \text{ ksi}$$

(a) circle: $c = \frac{1}{2} b$

$$\tau_{max} = \frac{Tc}{J} = \frac{2T}{\pi c^3} = \frac{16T}{\pi b^3}$$

$$b^3 = \frac{16T}{\pi \tau_{max}} = \frac{(16)(2)}{\pi(6)} = 1.698 \text{ in}^3$$

$$b = 1.193 \text{ in} \quad \blacktriangleleft$$

(b) square: $a = b$, $\frac{a}{b} = 1.0$. From Table 3.1 $c_1 = 0.208$

$$\tau_{max} = \frac{T}{c_1 a b^2} = \frac{T}{c_1 b^3} \therefore b^3 = \frac{T}{c_1 \tau_{max}} = \frac{2}{(0.208)(6)} = 1.603 \text{ in}^3$$

$$b = 1.170 \text{ in} \quad \blacktriangleleft$$

(c) rectangle: $a = 2b$, $\frac{a}{b} = 2.0$, $c_1 = 0.246$

$$\tau_{max} = \frac{T}{c_1 a b^2} = \frac{T}{2c_1 b^3} \therefore b^3 = \frac{T}{2c_1 \tau_{max}} = \frac{2}{(2)(0.246)(6)} = 0.668 \text{ in}^3$$

$$b = 0.878 \text{ in} \quad \blacktriangleleft$$

PROBLEM 3.127

3.127 A 300-N·m torque T is applied to each of the aluminum bars shown. Knowing that $\tau_{all} = 60$ MPa, determine the required dimension b for each bar.

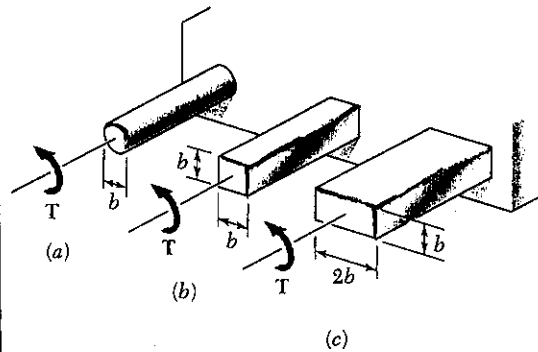

SOLUTION

$$T = 300 \text{ N}\cdot\text{m} \quad \tau_{max} = 60 \times 10^6 \text{ Pa}$$

(a) circle: $c = \frac{1}{2} b$

$$\tau_{max} = \frac{Tc}{J} = \frac{2T}{\pi c^3} = \frac{16T}{\pi b^3}$$

$$b^3 = \frac{16T}{\pi \tau_{max}} = \frac{(16)(300)}{\pi(60 \times 10^6)} = 25.46 \times 10^{-6} \text{ m}^3$$

$$b = 29.4 \times 10^{-3} \text{ m} = 29.4 \text{ mm} \quad \blacktriangleleft$$

(b) square: $a = b$, $\frac{a}{b} = 1.0$. From Table 3.1 $c_1 = 0.208$

$$\tau_{max} = \frac{T}{c_1 a b^2} = \frac{T}{c_1 b^3} \therefore b^3 = \frac{T}{c_1 \tau_{max}} = \frac{300}{(0.208)(60 \times 10^6)} = 24.04 \times 10^{-6} \text{ m}^3$$

$$b = 28.9 \times 10^{-3} \text{ m} = 28.9 \text{ mm} \quad \blacktriangleleft$$

(c) rectangle: $a = 2b$, $\frac{a}{b} = 2.0$, $c_1 = 0.246$

$$\tau_{max} = \frac{T}{c_1 a b^2} = \frac{T}{2c_1 b^3} \therefore b^3 = \frac{T}{2c_1 \tau_{max}} = \frac{300}{(2)(0.246)(60 \times 10^6)} = 10.16 \times 10^{-6} \text{ m}^3$$

$$b = 21.7 \times 10^{-3} \text{ m} = 21.7 \text{ mm} \quad \blacktriangleleft$$

PROBLEM 3.128

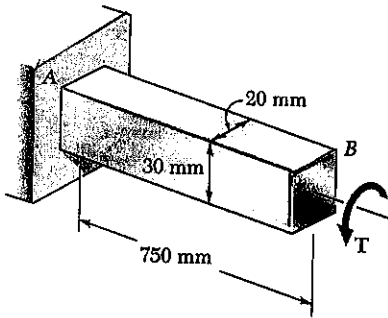

3.128 The torque T causes a rotation of 2° at end B of the stainless steel bar shown. Knowing that $G = 77 \text{ GPa}$, determine the maximum shearing stress in the bar.

SOLUTION

$$a = 30 \text{ mm} = 0.030 \text{ m}, \quad b = 20 \text{ mm} = 0.020 \text{ m}$$

$$\phi = 2^\circ = 34.907 \times 10^{-3} \text{ rad}$$

$$\phi = \frac{TL}{C_1 a b^3 G} \therefore T = \frac{C_2 a b^3 G \phi}{L}$$

$$\tau_{\max} = \frac{TL}{C_1 a b^2} = \frac{C_2 a b^3 G \phi}{C_1 a b^2 L} = \frac{C_2 b G \phi L}{C_1 L}$$

$$\frac{a}{b} = \frac{30}{20} = 1.5$$

From Table 3.1 $C_1 = 0.231$ $C_2 = 0.1958$

$$\tau_{\max} = \frac{(0.1958)(0.020)(77 \times 10^9)(34.907 \times 10^{-3})}{(0.231)(0.750)} = 60.8 \times 10^6 \text{ Pa}$$

$$= 60.8 \text{ MPa}$$

PROBLEM 3.129

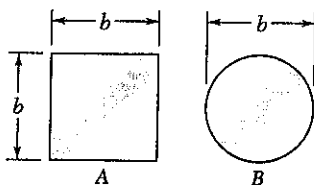

3.129 Two shafts are made of the same material. The cross section of shaft A is a square of side b and that of shaft B is a circle of diameter b . Knowing that the shafts are subjected to the same torque, determine the ratio of the maximum shearing stresses occurring in the shafts.

A. square $\frac{a}{b} = 1$, $C_1 = 0.208$ (Table 3.1)

$$\tau_A = \frac{T}{C_1 a b^2} = \frac{T}{0.208 b^3}$$

B. circle $c = \frac{1}{2}b$ $\tau_B = \frac{Tc}{J} = \frac{2T}{\pi c^3} = \frac{16T}{\pi b^3}$

Ratio $\frac{\tau_A}{\tau_B} = \frac{1}{0.208} \cdot \frac{\pi}{16} = 0.3005 \pi = 0.944$

PROBLEM 3.130

3.130 Determine the largest allowable square cross section of a steel shaft of length 4 m if the maximum shearing stress is not to exceed 100 MPa when the shaft is twisted through one complete revolution. Use $G = 77 \text{ GPa}$.

SOLUTION

$$\phi = 2\pi \text{ rad}, \quad L = 4 \text{ m}, \quad \tau_{\max} = 100 \times 10^6 \text{ Pa} \quad G = 77 \times 10^9 \text{ Pa}$$

square section: $C_1 = 0.208$ and $C_2 = 0.1406$ from Table 3.1

$$\tau_{\max} = \frac{T}{C_1 a b^2} = \frac{T}{C_1 b^3}, \quad \phi = \frac{TL}{C_2 a b^3 G} = \frac{TL}{C_2 b^4 G}$$

$$\frac{\tau_{\max}}{\phi} = \frac{T}{C_1 b^3} \cdot \frac{C_2 b^4 G}{TL} \therefore b = \frac{C_1 \tau_{\max} L}{C_2 G \phi} = \frac{(0.208)(100 \times 10^6)(4.0)}{(0.1406)(77 \times 10^9)(2\pi)}$$

$$= 1.223 \times 10^{-3} \text{ m} = 1.223 \text{ mm}$$

PROBLEM 3.131

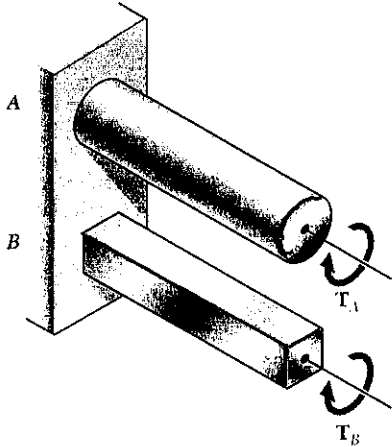

3.131 Shafts *A* and *B* are made of the same material and have the same cross sectional area, but *A* has a circular cross section and *B* has a square cross section. Determine the ratio of the maximum torques T_A and T_B which may be safely applied to *A* and *B*, respectively.

SOLUTION

Let c = radius of circular section *A* and b = side of square section *B*.

For equal areas $\pi c^2 = b^2$

$$c = \frac{b}{\sqrt{\pi}}$$

Circle: $\tau_A = \frac{T_A c}{J} = \frac{2 T_A}{\pi c^3} \therefore T_A = \frac{\pi}{2} c^3 \tau_A$

Square: $C_1 = 0.208$ from Table 3.1

$$\tau_B = \frac{T_B}{C_1 a b^2} = \frac{T_B}{C_1 b^3} \therefore T_B = C_1 b^3 \tau_B$$

$$\text{Ratio: } \frac{T_A}{T_B} = \frac{\frac{\pi}{2} c^3 \tau_B}{C_1 b^3 \tau_B} = \frac{\frac{\pi}{2} \cdot \frac{b^3}{\pi^{3/2}} \tau_A}{C_1 b^3 \tau_B} = \frac{1}{2 C_1 \sqrt{\pi}} \frac{\tau_A}{\tau_B}$$

For the same stresses $\tau_B = \tau_A \therefore \frac{T_A}{T_B} = \frac{1}{(2)(0.208)\sqrt{\pi}} = 1.356 \blacktriangleleft$

PROBLEM 3.132

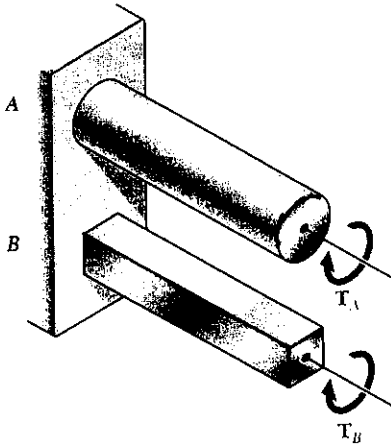

3.132 Shafts *A* and *B* are made of the same material and have the same length and cross sectional area, but *A* has a circular cross section and *B* has a square cross section. Determine the ratio of the maximum values if the angles ϕ_A and ϕ_B through which shafts *A* and *B*, respectively, may be twisted.

SOLUTION

Let c = radius of circular section *A* and b = side of square section *B*.

For equal areas $\pi c^2 = b^2 \therefore b = \sqrt{\pi} c$

Circle: $\gamma_{\max} = \frac{\tau_A}{G} = \frac{c \phi_A}{L} \therefore \phi_A = \frac{L \tau_A}{c G}$

Square: Table 3.1 $C_1 = 0.208, C_2 = 0.1406$

$$\tau_B = \frac{T_B}{C_1 a b^2} = \frac{T_B}{0.208 b^3} \therefore T_B = 0.208 b^3 \tau_B$$

$$\phi_B = \frac{T_B L}{C_2 a b^3 G} = \frac{0.208 b^3 \tau_B L}{0.1406 b^4 G} = \frac{1.4794 L \tau_B}{b G}$$

$$\text{Ratio } \frac{\phi_A}{\phi_B} = \frac{L \tau_A}{c G} \cdot \frac{b G}{1.4794 L \tau_B} = 0.676 \frac{b \tau_A}{c \tau_B} = 0.676 \sqrt{\pi} \frac{\tau_A}{\tau_B}$$

For equal stresses $\tau_A = \tau_B \quad \frac{\phi_B}{\phi_A} = 0.676 \sqrt{\pi} = 1.198 \blacktriangleleft$

PROBLEM 3.133

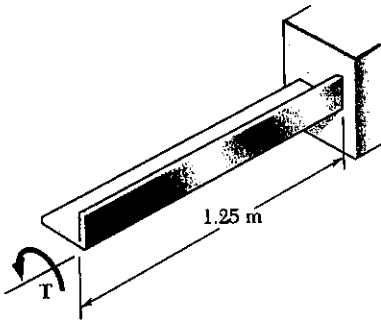

3.133 A 1.25-m-long steel angle has an L 127 × 76 × 6.4 cross section. From Appendix C we find that the thickness of the section is 6.4 mm and that its area is 1252 mm². Knowing that $\tau_{\text{all}} = 60$ MPa, $G = 77$ GPa, and ignoring the effect of stress concentrations, determine (a) the largest torque T which may be applied, (b) the corresponding angle of twist.

SOLUTION

$$A = 1252 \text{ mm}^2 \quad b = 6.4 \text{ mm} = 0.0064 \text{ m}$$

$$a = \frac{A}{b} = \frac{1252}{6.4} = 195.6 \text{ mm} = 0.1956 \text{ m}$$

$$\frac{a}{b} = \frac{195.6}{6.4} = 30.56$$

$$c_1 = c_2 = \frac{1}{3} \left(1 - 0.630 \frac{b}{a} \right) = 0.3265$$

$$\gamma_{\text{max}} = \frac{T}{c_1 a b^2} \therefore T = c_1 a b^2 \gamma_{\text{max}}$$

$$(a) \quad T = (0.3265)(0.1956)(0.0064)^2(60 \times 10^6) = 156.95 \times 10^3 \text{ N}\cdot\text{m}$$

$$= 157.0 \text{ kN}\cdot\text{m} \quad \blacktriangleleft$$

$$(b) \quad \phi = \frac{TL}{c_2 a b^3 G} = \frac{c_1 a b^2 \gamma_{\text{max}} L}{c_2 a b^3 G} = \frac{c_1 \gamma_{\text{max}} L}{c_2 b G} = \frac{\gamma_{\text{max}} L}{b G}$$

$$\phi = \frac{(60 \times 10^6)(1.25)}{(0.0064)(77 \times 10^9)} = 152.19 \times 10^{-3} \text{ rad} = 8.72^\circ \quad \blacktriangleleft$$

PROBLEM 3.134

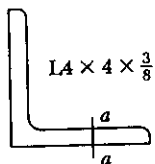

L 4 × 4 × $\frac{3}{8}$

SOLUTION

3.134 A 3000 lb·in. torque is applied to a 6-ft-long steel angle with a L 4 × 4 × $\frac{3}{8}$ cross section. From Appendix C we find that the thickness of the section is $\frac{3}{8}$ in. and that its area is 2.86 in². Knowing that $G = 11.2 \times 10^6$ psi, determine (a) the maximum shearing stress along line $a-a$, (b) the angle of twist.

$$A = 2.86 \text{ in}^2, \quad b = \frac{3}{8} \text{ in} = 0.375 \text{ in}, \quad a = \frac{A}{b} = \frac{2.86}{0.375} = 7.627 \text{ in.}$$

$$\frac{a}{b} = \frac{7.627}{0.375} = 20.34 \quad c_1 = c_2 = \frac{1}{3} \left(1 - 0.630 \frac{b}{a} \right) = 0.3230$$

$$(a) \quad \gamma_{\text{max}} = \frac{T}{c_1 a b^2} = \frac{3000}{(0.3230)(7.627)(0.375)^2} = 8.66 \times 10^3 \text{ psi} = 8.66 \text{ ksi} \quad \blacktriangleleft$$

$$(b) \quad \phi = \frac{TL}{c_2 a b^3 G} = \frac{(3000)(72)}{(0.3230)(7.627)(0.375)^3(11.2 \times 10^6)} = 148.45 \times 10^{-3} \text{ rad}$$

$$= 8.51^\circ \quad \blacktriangleleft$$

Note: $L = 6 \text{ ft.} = 72 \text{ in.}$

PROBLEM 3.135

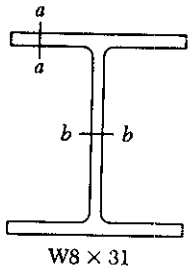

3.135 An 8-ft-long steel member with a W 8 × 31 cross section is subjected to a 5 kip-in. torque. From Appendix C we find that the thickness of the section is $\frac{3}{8}$ in. and that its area is 2.86 in^2 . Knowing that $G = 11.2 \times 10^6$ psi, determine (a) the maximum shearing stress along line a-a, (b) the maximum shearing stress along line b-b, (c) the angle of twist. (Hint: Consider the web and flanges separately and obtain a relation between the torques exerted on the web and a flange, respectively, by expressing that the resulting angles of twist are equal.)

SOLUTION

Flange: $a = 7.995 \text{ in}$, $b = 0.435$, $\frac{a}{b} = \frac{7.995}{0.435} = 18.38$

$$C_1 = C_2 = \frac{1}{3} \left(1 - 0.630 \frac{b}{a} \right) = 0.3219 \quad \phi_F = \frac{T_F L}{C_2 a b^3 G}$$

$$T_F = C_2 a b^3 \frac{G \phi_F}{L} = K_F \frac{G \phi}{L} \quad \text{where } K_F = C_2 a b^3$$

$$K_F = (0.3219)(7.995)(0.435)^3 = 0.2138 \text{ in}^4$$

Web: $a = 8.0 - (2)(0.435) = 7.13 \text{ in}$, $b = 0.285 \text{ in}$, $\frac{a}{b} = \frac{7.13}{0.285} = 25.02$

$$C_1 = C_2 = \frac{1}{3} \left(1 - 0.630 \frac{b}{a} \right) = 0.3249 \quad \phi_w = \frac{T_w L}{C_2 a b^3 G}$$

$$T_w = C_2 a b^3 \frac{G \phi_w}{L} = K_w \frac{G \phi}{L} \quad \text{where } K_w = C_2 a b^3$$

$$K_w = (0.3249)(7.13)(0.285)^3 = 0.0563 \text{ in}^4$$

For matching twist angles $\phi_F = \phi_w = \phi$

$$\text{Total torque } T = 2T_F + T_w = (2K_F + K_w) \frac{G \phi}{L}$$

$$\frac{G \phi}{L} = \frac{T}{2K_F + K_w}, \quad T_F = \frac{K_F T}{2K_F + K_w}, \quad T_w = \frac{K_w T}{2K_F + K_w}$$

$$T_F = \frac{(0.2138)(5000)}{(2)(0.2138) + 0.0563} = 2221 \text{ lb}\cdot\text{in}; \quad T_w = \frac{(0.0563)(5000)}{(2)(0.2138) + 0.0563} = 557 \text{ lb}\cdot\text{in}$$

$$(a) \tau_F = \frac{T_F}{C_1 a b^2} = \frac{2221}{(0.3219)(7.995)(0.435)^2} = 4570 \text{ psi} = 4.57 \text{ ksi} \quad \blacktriangleleft$$

$$(b) \tau_w = \frac{T_w}{C_1 a b^2} = \frac{557}{(0.3249)(7.13)(0.285)^2} = 2960 \text{ psi} = 2.96 \text{ ksi} \quad \blacktriangleleft$$

$$(c) \frac{G \phi}{L} = \frac{T}{2K_F + K_w} \quad \therefore \phi = \frac{TL}{G(2K_F + K_w)} \quad \text{where } L = 8 \text{ ft} = 96 \text{ in.}$$

$$\phi = \frac{(5000)(96)}{(11.2 \times 10^6)[(2)(0.2138) + 0.0563]} = 88.6 \times 10^{-3} \text{ rad} = 5.08^\circ \quad \blacktriangleleft$$

PROBLEM 3.136

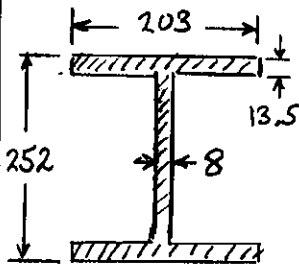
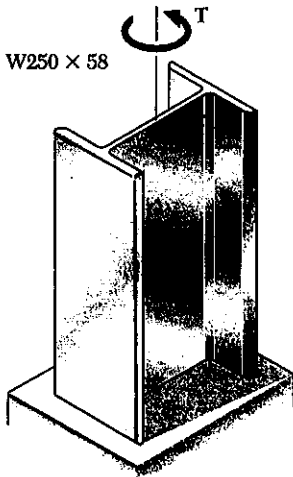

3.136 A 3-m-long steel member has an W 250 × 58 cross section. Knowing that $G = 77$ GPa and that the allowable shearing stress is 35 MPa, determine (a) the largest torque T which may be applied, (b) the corresponding angle of twist. Refer to Appendix C for the dimensions of the cross section and neglect the effect of stress concentrations. (See hint of Prob. 3.135.)

SOLUTION

Flange: $a = 203$ mm, $b = 13.5$ mm, $\frac{a}{b} = 15.04$

$$C_1 = C_2 = \frac{1}{3} \left(1 - 0.630 \frac{b}{a} \right) = 0.3194$$

$$\Phi_F = \frac{T_F L}{C_2 a b^3 G} \quad \therefore T_F = C_2 a b^3 \frac{G \Phi}{L} = K_F \frac{G \Phi}{L}$$

$$K_F = (0.3194)(0.203)(0.0135)^3 = 159.53 \times 10^{-9} \text{ m}^4$$

Web: $a = 252 - (2)(13.5) = 225$ mm, $b = 8$ mm

$$\frac{a}{b} = 28.13, \quad C_1 = C_2 = \frac{1}{3} \left(1 - 0.63 \frac{b}{a} \right) = 0.3259$$

$$\Phi_w = \frac{T_w L}{C_2 a b^3 G} \quad \therefore T_w = C_2 a b^3 \frac{G \Phi}{L} = K_w \frac{G \Phi}{L}$$

$$K_w = (0.3259)(0.225)(0.008)^3 = 37.54 \times 10^{-9} \text{ m}^4$$

For matching twist angles $\Phi_F = \Phi_w = \Phi$

Total torque: $T = 2T_F + T_w = (2K_F + K_w) \frac{G \Phi}{L}$

$$\frac{G \Phi}{L} = \frac{T}{2K_F + K_w}, \quad T_F = \frac{K_F T}{2K_F + K_w} \quad \therefore T = \frac{2K_F + K_w}{K_F} T_F$$

$$T_w = \frac{K_w T}{2K_F + K_w} \quad \therefore T = \frac{2K_F + K_w}{K_w} T_w$$

Allowable value for T based on allowable value for T_F

$$T_F = C_1 a b^2 \tau = (0.3194)(0.203)(0.0135)^2 (35 \times 10^6) = 413.6 \text{ N}\cdot\text{m}$$

$$T = \frac{(2)(159.53) + (37.54)}{159.53} (413.6) = 924.5 \text{ N}\cdot\text{m}$$

Allowable value for T base on allowable value for T_w

$$T_w = C_1 a b^2 \tau = (0.3259)(0.225)(0.008)^2 (35 \times 10^6) = 164.25 \text{ N}\cdot\text{m}$$

$$T = \frac{(2)(159.53) + 37.54}{37.54} (164.25) = 1560 \text{ N}\cdot\text{m}$$

Choose smaller value

$$T = 925 \text{ N}\cdot\text{m} \quad \blacktriangleleft$$

$$\Phi = \frac{TL}{(2K_F + K_w)G} = \frac{(924.5)(3.00)}{(356.6 \times 10^{-9})(77 \times 10^9)} = 101.0 \times 10^{-5} \text{ rad} = 5.79^\circ \quad \blacktriangleleft$$

PROBLEM 3.137

3.137 and 3.138 A 750-N·m torque T is applied to a hollow shaft having the cross section shown. Neglecting the effect of stress concentration, determine the shearing stress at points a and b . Thickness = 6 mm.

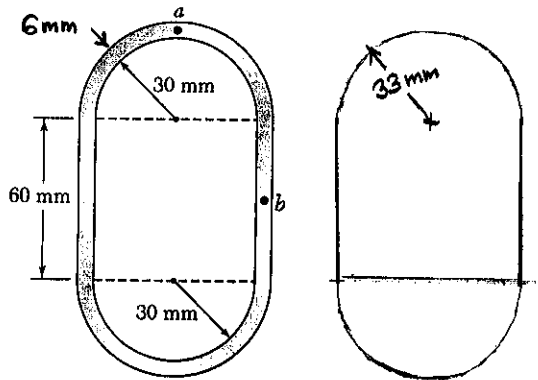

SOLUTION

Area bounded by center line

$$Q = 2 \frac{\pi}{2} (33)^2 + (60)(66) = 7381 \text{ mm}^2$$

$$= 7381 \times 10^{-6} \text{ m}^2$$

$$t = 0.006 \text{ m at both } a \text{ and } b.$$

$$\tau = \frac{T}{2tQ} = \frac{750}{(2)(0.006)(7381 \times 10^{-6})} = 8.47 \times 10^6 \text{ Pa} = 8.47 \text{ MPa} \blacktriangleleft$$

PROBLEM 3.138

3.137 and 3.138 A 750-N·m torque T is applied to a hollow shaft having the cross section shown. Neglecting the effect of stress concentration, determine the shearing stress at points a and b . Thickness = 8 mm.

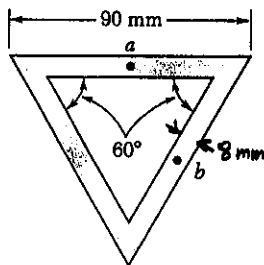

SOLUTION

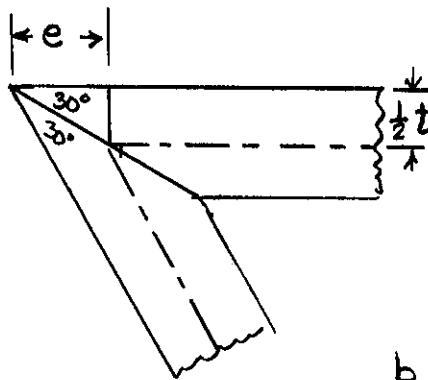
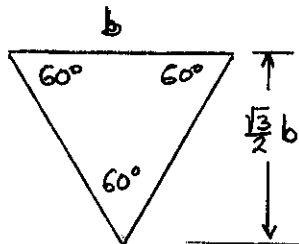

Detail of corner

$$\frac{1}{2}t = e \tan 30^\circ$$

$$e = \frac{t}{2 \tan 30^\circ}$$

$$= \frac{8}{2 \tan 30^\circ} = 6.928 \text{ mm}$$

$$b = 90 - 2e = 76.144 \text{ mm}$$

Area bounded by center line

$$Q = \frac{1}{2} b \frac{\sqrt{3}}{2} b = \frac{\sqrt{3}}{4} b^2 = \frac{\sqrt{3}}{4} (76.144)^2$$

$$= 2510.6 \text{ mm}^2 = 2510.6 \times 10^{-6} \text{ m}^2$$

$$t = 0.008 \text{ m}$$

$$\tau = \frac{T}{2tQ} = \frac{750}{(2)(0.008)(2510.6 \times 10^{-6})} = 18.67 \times 10^6 \text{ Pa}$$

$$= 18.67 \text{ MPa} \blacktriangleleft$$

PROBLEM 3.139

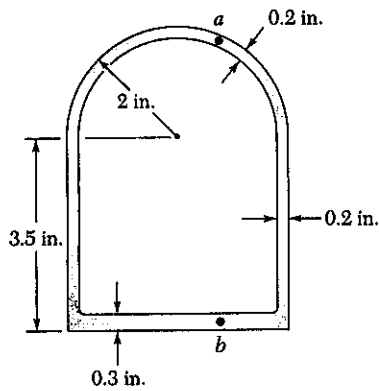

3.139 and 3.140 A 50-kip-in. torque T is applied to a hollow shaft having the cross section shown. Neglecting the effect of stress concentration, determine the shearing stress at points a and b .

SOLUTION

Area bounded by center line.

$$A = \frac{\pi}{2}(1.9)^2 + (3.35)(3.8) = 18.40 \text{ in}^2$$

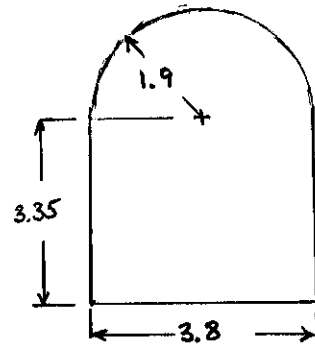

At point a $t = 0.2 \text{ in}$

$$\tau = \frac{T}{2tA} = \frac{50}{(2)(0.2)(18.40)} = 6.79 \text{ ksi}$$

At point b $t = 0.3 \text{ in}$

$$\tau = \frac{T}{2tA} = \frac{50}{(2)(0.3)(18.40)} = 4.53 \text{ ksi}$$

PROBLEM 3.140

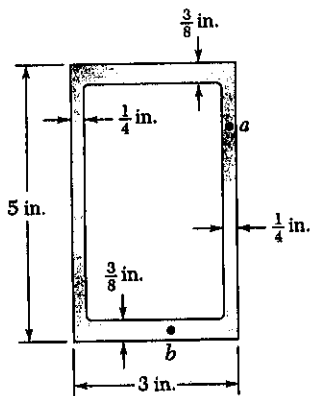

3.139 and 3.140 A 50-kip-in. torque T is applied to a hollow shaft having the cross section shown. Neglecting the effect of stress concentration, determine the shearing stress at points a and b .

SOLUTION

Area bounded by centerline

$$A = (2\frac{3}{4})(4\frac{5}{8}) = 12\frac{23}{32} = 12.719 \text{ in}^2$$

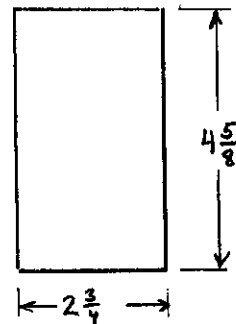

At point a $t = \frac{1}{4} \text{ in} = 0.25 \text{ in}$

$$\tau = \frac{T}{2tA} = \frac{50}{(2)(0.25)(12.719)} = 7.86 \text{ ksi}$$

At point b $t = \frac{3}{8} \text{ in} = 0.375 \text{ in}$

$$\tau = \frac{T}{2tA} = \frac{50}{(2)(0.375)(12.719)} = 5.24 \text{ ksi}$$

PROBLEM 3.141

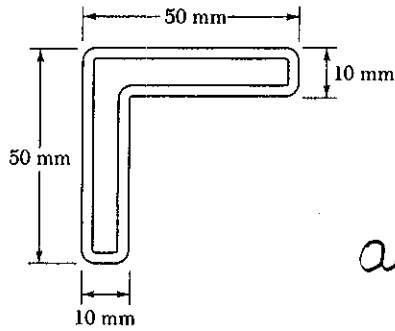

3.141 and 3.142 A hollow member having the cross section shown is formed from sheet metal of 2-mm thickness. Knowing that the shearing stress must not exceed 3 MPa, determine the largest torque which may be applied to the member.

SOLUTION

Area bounded by centerline

$$A = (48)(8) + (40)(8) = 704 \text{ mm}^2 = 704 \times 10^{-6} \text{ m}^2$$

$$t = 0.002 \text{ m}$$

$$\tau = \frac{T}{2tA} \quad \therefore \quad T = 2tA\tau = (2)(0.002)(704 \times 10^{-6})(3 \times 10^6) = 8.45 \text{ N}\cdot\text{m}$$

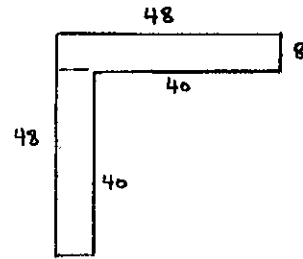

PROBLEM 3.142

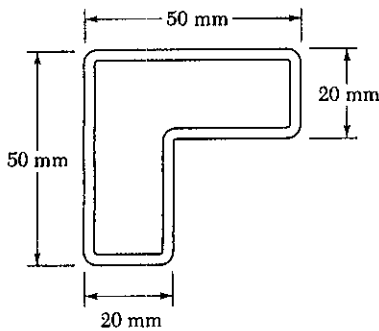

3.141 and 3.142 A hollow member having the cross section shown is formed from sheet metal of 2-mm thickness. Knowing that the shearing stress must not exceed 3 MPa, determine the largest torque which may be applied to the member.

SOLUTION

Area bounded by centerline

$$A = (48)(18) + (30)(18) = 1404 \text{ mm}^2 = 1404 \times 10^{-6} \text{ m}^2$$

$$t = 0.002 \text{ m}$$

$$\tau = \frac{T}{2tA} \quad \therefore \quad T = 2tA\tau = (2)(0.002)(1404 \times 10^{-6})(3 \times 10^6) = 16.85 \text{ N}\cdot\text{m}$$

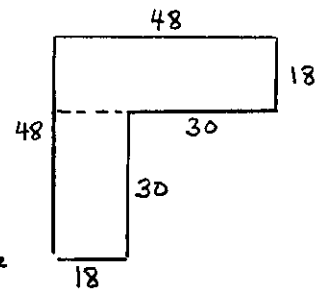

PROBLEM 3.143

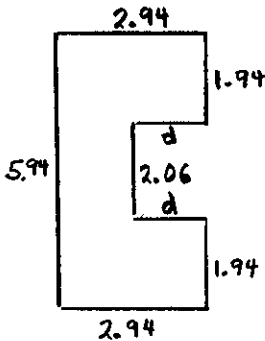
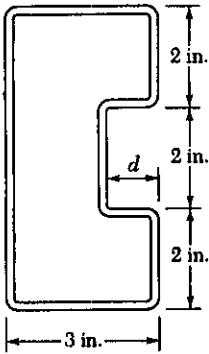

3.143 and 3.144 A hollow member having the cross section shown is to be formed from sheet metal of 0.06 in. thickness. Knowing that a 1250 lb·in. torque will be applied to the member, determine the smallest dimension d which may be used if the shearing stress is not to exceed 750 psi.

SOLUTION

Area bounded by centerline

$$A = (5.94)(2.94) - 2.06d = 17.4636 - 2.06d$$

$$t = 0.06 \text{ in.}, \quad \tau = 750 \text{ psi}, \quad T = 1250 \text{ lb}\cdot\text{in}$$

$$\tau = \frac{T}{2tA}$$

$$A = \frac{T}{2t\tau}$$

$$17.4636 - 2.06d = \frac{1250}{(2)(0.06)(750)} = 13.8889$$

$$d = \frac{3.5747}{2.06} = 1.735 \text{ in}$$

PROBLEM 3.144

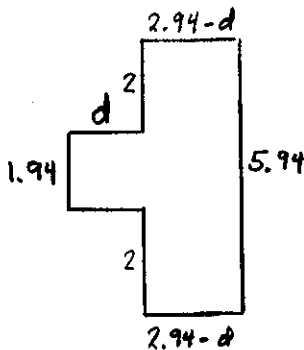
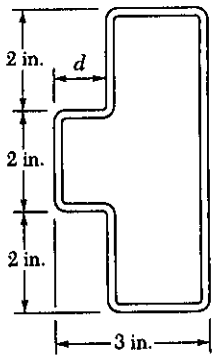

3.143 and 3.144 A hollow member having the cross section shown is to be formed from sheet metal of 0.06 in. thickness. Knowing that a 1250 lb·in. torque will be applied to the member, determine the smallest dimension d which may be used if the shearing stress is not to exceed 750 psi.

SOLUTION

Area bounded by center

$$A = (5.94)(2.94 - d) + 1.94d = 17.4636 - 4.00d$$

$$t = 0.06 \text{ in.}, \quad \tau = 750 \text{ psi}, \quad T = 1250 \text{ lb}\cdot\text{in}$$

$$\tau = \frac{T}{2tA}$$

$$A = \frac{T}{2t\tau}$$

$$17.4636 - 4.00d = \frac{1250}{(2)(0.06)(750)} = 13.8889$$

$$d = \frac{3.5747}{4.00} = 0.894 \text{ in.}$$

PROBLEM 3.145

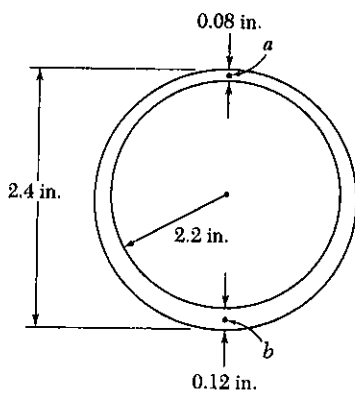

3.145 A hollow cylindrical shaft was designed to have a uniform wall thickness of 0.1 in. Defective fabrication, however, resulted in the shaft having the cross section shown. Knowing that a 15-kip·in. torque T is applied to the shaft, determine the shearing stress at points a and b .

SOLUTION

Radius of outer circle = 1.2 in

Radius of inner circle = 1.1 in

Mean radius = 1.15 in

Area bounded by centerline

$$A = \pi r_m^2 = \pi (1.15)^2 = 4.155 \text{ in}^2$$

At point a $t = 0.08 \text{ in}$ $\tau = \frac{T}{2tA} = \frac{15}{(2)(0.08)(4.155)} = 22.6 \text{ ksi}$ \blacktriangleleft

At point b $t = 0.12 \text{ in}$ $\tau = \frac{T}{2tA} = \frac{15}{(2)(0.12)(4.155)} = 15.04 \text{ ksi}$ \blacktriangleleft

PROBLEM 3.146

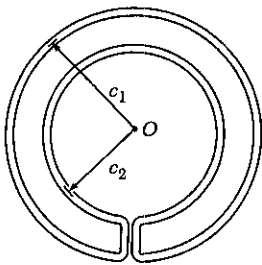

3.146 A cooling tube having the cross section shown is formed from a sheet of stainless steel of 3 mm thickness. The radii $c_1 = 150 \text{ mm}$ and $c_2 = 100 \text{ mm}$ are measured to the centerline of the sheet metal. Knowing that a torque of magnitude $T = 3 \text{ kN}\cdot\text{m}$ is applied to the tube, determine (a) the maximum shearing stress in the tube, (b) the magnitude of the torque carried by the outer circular shell. Neglect the dimension of the small opening where the outer and inner shells are connected.

SOLUTION

Area bounded by centerline

$$A = \pi (c_1^2 - c_2^2) = \pi (150^2 - 100^2) = 39.27 \times 10^3 \text{ mm}^2$$

$$= 39.27 \times 10^{-3} \text{ m}^2$$

$$t = 0.003 \text{ m}$$

(a) $\tau = \frac{T}{2tA} = \frac{3 \times 10^3}{(2)(0.003)(39.27 \times 10^{-3})} = 12.73 \times 10^6 \text{ Pa} = 12.73 \text{ MPa}$ \blacktriangleleft

(b) $T_1 = (2\pi c_1 t \tau c_1) = 2\pi c_1^2 t \tau$

$$= 2\pi (0.150)^2 (0.003) (12.73 \times 10^6) = 5.46 \times 10^3 \text{ N}\cdot\text{m}$$

$$= 5.40 \text{ kN}\cdot\text{m}$$
 \blacktriangleleft

PROBLEM 3.147

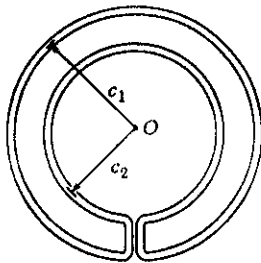

3.147 A cooling tube having the cross section as shown is formed from a sheet of stainless steel of thickness t . The radii c_1 and c_2 are measured to the centerline of the sheet metal. Knowing that a torque T applied to the tube, determine in terms of T , c_1 , c_2 , and t the maximum shearing stress in the tube.

SOLUTION

Area bounded by centerline

$$A = \pi (c_1^2 - c_2^2)$$

Shearing stress

$$\tau = \frac{T}{2tA} = \frac{T}{2\pi t(c_1^2 - c_2^2)}$$

PROBLEM 3.148

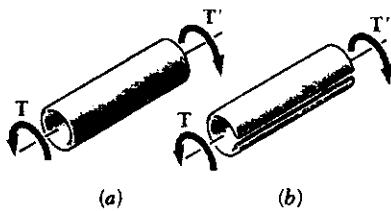

3.148 Equal torques are applied to thin-walled tubes of the same length L , same thickness t , and same radius c . One of the tubes has been slit lengthwise as shown. Determine (a) the ratio τ_b/τ_a of the maximum shearing stresses in the tubes, (b) the ratio ϕ_b/ϕ_a of the angles of twist of the shafts.

SOLUTION

Without slit

Area bounded by centerline: $A = \pi c^2$

$$\tau_a = \frac{T}{2tA} = \frac{T}{2\pi c^2 t}$$

$$J \approx 2\pi c^3 t$$

$$\phi_a = \frac{TL}{GJ} = \frac{TL}{2\pi c^3 t G}$$

With slit: $a = 2\pi c$, $b = t$, $\frac{a}{b} = \frac{2\pi c}{t} \gg 1$

$$c_1 = c_2 = \frac{1}{3}$$

$$\tau_b = \frac{T}{c_1 a b^2} = \frac{3T}{2\pi c t^2}$$

$$\phi_b = \frac{T}{c_2 a b^3 G} = \frac{3TL}{2\pi c t^3 G}$$

Stress ratio: $\frac{\tau_b}{\tau_a} = \frac{3T}{2\pi c t^2} \cdot \frac{2\pi c^2 t}{T} = \frac{3c}{t}$

Twist ratio: $\frac{\phi_b}{\phi_a} = \frac{3TL}{2\pi c t^3 G} \cdot \frac{2\pi c^3 t G}{TL} = \frac{3c^2}{t^2}$

PROBLEM 3.149

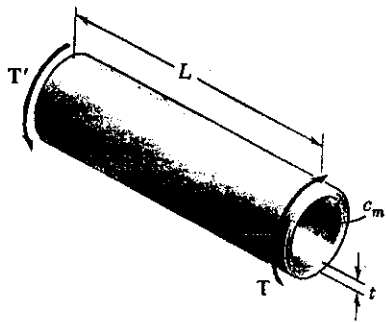

3.149 A hollow cylindrical shaft of length L , mean radius c_m , and uniform thickness t is subjected to torques of magnitude T . Consider, on the one hand, the values of the average shearing stress τ_{ave} and the angle of twist ϕ obtained from the elastic torsion formulas developed in Secs. 3.4 and 3.5 and, on the other hand, the corresponding values obtained from the formulas developed in Sec. 3.13 for thin-walled hollow shafts. (a) Show that the relative error introduced by using the thin-wall-shaft formulas rather than the elastic torsion formulas is the same for τ_{ave} and ϕ and that the relative error is positive and proportional to the square of the ratio t/c_m . (b) Compare the percent error corresponding to values of the ratio t/c_m equal 0.1, 0.2 and 0.4.

SOLUTION

Let $c_2 =$ outer radius $= c_m + \frac{1}{2}t$ and $c_1 =$ inner radius $= c_m - \frac{1}{2}t$

$$J = \frac{\pi}{2}(c_2^4 - c_1^4) = \frac{\pi}{2}(c_2^2 + c_1^2)(c_2 + c_1)(c_2 - c_1)$$

$$= \frac{\pi}{2}(c_m^2 + c_m t + \frac{1}{4}t^2 + c_m^2 - c_m t + \frac{1}{4}t^2)(2c_m)t$$

$$= 2\pi(c_m^2 + \frac{1}{4}t^2)c_m t$$

$$\tau_m = \frac{T c_m}{J} = \frac{T}{2\pi(c_m^2 + \frac{1}{4}t^2)t}$$

$$\phi_1 = \frac{TL}{JG} = \frac{TL}{2\pi(c_m^2 + \frac{1}{4}t^2)c_m t G}$$

Area bounded by centerline $Q = \pi c_m^2$

$$\tau_{ave} = \frac{T}{2tQ} = \frac{T}{2\pi c_m^2 t}$$

$$\phi_2 = \frac{TL}{4Q^2 G} \int \frac{ds}{t} = \frac{TL(2\pi c_m/t)}{4(\pi c_m^2)^2 G} = \frac{TL}{2\pi c_m^3 t G}$$

$$\text{Ratios: } \frac{\tau_{ave}}{\tau_m} = \frac{T}{2\pi c_m^2 t} \cdot \frac{2\pi(c_m^2 + \frac{1}{4}t^2)t}{T} = 1 + \frac{1}{4} \frac{t^2}{c_m^2}$$

$$\frac{\phi_2}{\phi_1} = \frac{TL}{2\pi c_m^3 t G} \cdot \frac{2\pi(c_m^2 + \frac{1}{4}t^2)c_m t G}{TL} = 1 + \frac{1}{4} \frac{t^2}{c_m^2}$$

$$\frac{\tau_{ave}}{\tau_m} - 1 = \frac{\phi_2}{\phi_1} - 1 = \frac{1}{4} \frac{t^2}{c_m^2}$$

$\frac{t}{c_m}$	0.1	0.2	0.4
$\frac{1}{4} \frac{t^2}{c_m^2}$	0.0025	0.01	0.04
	0.25%	1%	4%

PROBLEM 3.150

3.150 For the solid brass shaft shown, determine the maximum shearing stress in (a) portion AB, (b) portion BC.

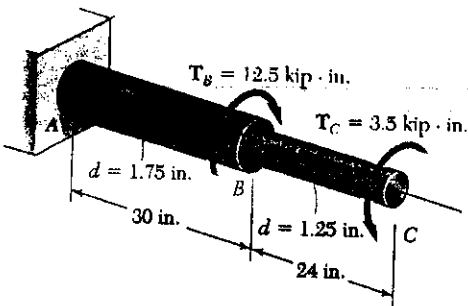

SOLUTION

AB: $T = 12.5 - 3.5 = 9 \text{ kip}\cdot\text{in}$, $c = \frac{1}{2}d = 0.875 \text{ in}$

$$\tau = \frac{Tc}{J} = \frac{2T}{\pi c^3} = \frac{(2)(9)}{\pi(0.875)^3} = 8.55 \text{ ksi} \quad \blacktriangleleft$$

BC: $T = 3.5 \text{ kip}\cdot\text{in}$, $c = \frac{1}{2}d = 0.625 \text{ in}$

$$\tau = \frac{Tc}{J} = \frac{2T}{\pi c^3} = \frac{(2)(3.5)}{\pi(0.625)^3} = 9.13 \text{ ksi} \quad \blacktriangleleft$$

PROBLEM 3.151

3.151 Knowing that $G = 5.6 \times 10^6 \text{ psi}$ for the solid brass shaft shown, determine the angle of twist at point C.

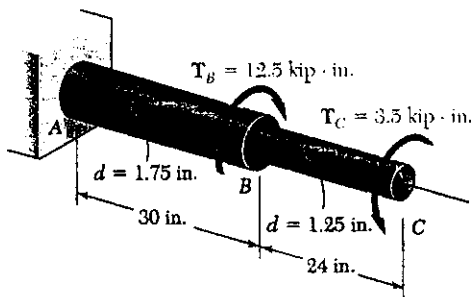

SOLUTION

AB: $T = 12.5 - 3.5 = 9 \text{ kip}\cdot\text{in}$, $c = \frac{1}{2}d = 0.875 \text{ in}$

$$G = 5.6 \times 10^6 \text{ psi} = 5.6 \times 10^3 \text{ ksi}$$

$$J_{AB} = \frac{\pi}{2}c^4 = \frac{\pi}{2}(0.875)^4 = 0.92077 \text{ in}^4$$

$$\phi_{AB} = \frac{T_{AB} L_{AB}}{G J_{AB}} = \frac{(9)(30)}{(5.6 \times 10^3)(0.92077)} = 52.36 \times 10^{-3} \text{ rad}$$

BC: $T = 3.5 \text{ kip}\cdot\text{in}$, $c = \frac{1}{2}d = 0.625 \text{ in}$

$$J_{BC} = \frac{\pi}{2}c^4 = \frac{\pi}{2}(0.625)^4 = 0.23968 \text{ in}^4$$

$$\phi_{BC} = \frac{T_{BC} L_{BC}}{G J} = \frac{(3.5)(24)}{(5.6 \times 10^3)(0.23968)} = 62.60 \times 10^{-3} \text{ rad}$$

Net angle of twist $\phi_{BC} - \phi_{AB} = 10.24 \times 10^{-3} \text{ rad} = 0.587^\circ \quad \blacktriangleleft$

PROBLEM 3.152



3.152 The stepped shaft shown rotates at 900 rpm. Knowing that $\tau_{all} = 42$ MPa, determine the maximum power which can be transmitted if the radius r of the fillet is (a) 12 mm, (b) 20 mm.

SOLUTION

$$\text{frequency } f = \frac{900 \text{ rpm}}{60 \text{ rpm/Hz}} = 15 \text{ Hz}$$

$$D = 160 \text{ mm}, \quad d = 80 \text{ mm}, \quad \tau_{all} = 42 \text{ MPa} = 42 \times 10^6 \text{ Pa}$$

$$c = \frac{1}{2}d = 40 \text{ mm} = 0.040 \text{ m} \quad \frac{D}{d} = \frac{160}{80} = 2.0$$

$$(a) \quad r = 12 \text{ mm}, \quad \frac{r}{d} = \frac{12}{80} = 0.15 \quad K = 1.33$$

$$\tau = \frac{KTc}{J} = \frac{2KT}{\pi c^3}$$

$$T = \frac{\pi c^3 \tau}{2K} = \frac{\pi (0.040)^3 (42 \times 10^6)}{(2)(1.33)} = 3.175 \times 10^3 \text{ N}\cdot\text{m}$$

$$P = 2\pi f T = (2\pi)(15)(3.175 \times 10^3) = 300 \times 10^3 \text{ W} = 300 \text{ kW} \quad \blacktriangleleft$$

$$(b) \quad r = 20 \text{ mm}, \quad \frac{r}{d} = \frac{20}{80} = 0.25 \quad K = 1.20$$

$$T = \frac{\pi c^3 \tau}{2K} = \frac{(\pi)(0.040)^3 (42 \times 10^6)}{(2)(1.20)} = 3.520 \times 10^3 \text{ N}\cdot\text{m}$$

$$P = 2\pi f T = (2\pi)(15)(3.520 \times 10^3) = 332 \times 10^3 \text{ W} = 332 \text{ kW} \quad \blacktriangleleft$$

PROBLEM 3.153

3.153 The long, hollow, tapered shaft AB has a uniform thickness t . Denoting by G the modulus of rigidity, shown that the angle of twist at end A is

$$\phi_A = \frac{TL}{4\pi Gt} \frac{c_A + c_B}{c_A^2 c_B^2}$$

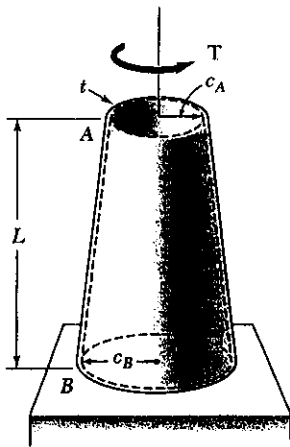

SOLUTION

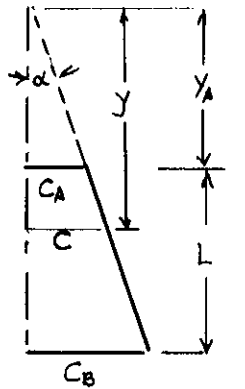

From geometry

$$\tan \alpha = \frac{c_B - c_A}{L}$$

$$c = y \tan \alpha = \frac{c_B - c_A}{L} y$$

$$y_A = \frac{c_A}{\tan \alpha} = \frac{c_A L}{c_B - c_A}$$

$$y_B = \frac{c_B}{\tan \alpha} = \frac{c_B L}{c_B - c_A}$$

$$J = 2\pi c^3 t = 2\pi \frac{(c_B - c_A)^3}{L^3} y^3 t$$

$$\phi = \int_{y_A}^{y_B} \frac{T dy}{GJ} = \frac{TL^3}{2\pi (c_B - c_A)^3 t G} \int_{y_A}^{y_B} \frac{dy}{y^3} = \frac{TL^3}{2\pi (c_B - c_A)^3 t G} \left(-\frac{1}{2y^2} \Big|_{y_A}^{y_B} \right)$$

$$= \frac{TL^3}{4\pi (c_B - c_A)^3 t G} \left\{ \frac{1}{y_A^2} - \frac{1}{y_B^2} \right\} = \frac{TL^3}{4\pi (c_B - c_A)^3 t G} \left\{ \frac{(c_B - c_A)^2}{L^2 c_A^2} - \frac{(c_B - c_A)^2}{L^2 c_B^2} \right\}$$

$$= \frac{TL}{4\pi (c_B - c_A) t G} \left\{ \frac{1}{c_A^2} - \frac{1}{c_B^2} \right\} = \frac{TL (c_B^2 - c_A^2)}{4\pi (c_B - c_A) t G c_A^2 c_B^2}$$

$$= \frac{TL (c_B + c_A)}{4\pi Gt c_A^2 c_B^2}$$

PROBLEM 3.154

3.154 Two solid steel shafts, each of 30-mm diameter, are connected by the gears shown. Knowing that $G = 77 \text{ GPa}$, determine the angle through which end A rotates when a 200-N·m torque T is applied at A .

SOLUTION

Calculation of torques

Circumferential contact force between gears B and D

$$F = \frac{T_{AB}}{r_B} = \frac{T_{DE}}{r_D}$$

$$T_{DE} = \frac{r_D}{r_B} T_{AB} = \frac{90}{60} (200) = 300 \text{ N}\cdot\text{m}$$

Twist in shaft DE

$$J_{DE} = \frac{\pi}{2} C^4 = \frac{\pi}{2} (0.015)^4 = 79.522 \times 10^{-9} \text{ m}^4$$

$$L_{DE} = 0.5 \text{ m}$$

$$\phi_{DE} = \frac{T_{DE} L_{DE}}{G J_{DE}} = \frac{(300)(0.5)}{(77 \times 10^9)(79.522 \times 10^{-9})} = 24.497 \times 10^{-3} \text{ rad.}$$

Rotation at D $\phi_D = \phi_{DE} = 24.497 \times 10^{-3} \text{ rad}$

Circumferential displacement at gear circles $\delta = r_D \phi_D = r_B \phi_B$

Rotation at B $\phi_B = \frac{r_D}{r_B} \phi_D = \frac{90}{60} (24.497 \times 10^{-3}) = 36.745 \times 10^{-3} \text{ rad}$

Twist in shaft AB

$$L_{AB} = 0.1 + 0.2 + 0.4 + 0.2 = 0.9 \text{ m}, \quad J_{AB} = 79.522 \times 10^{-9} \text{ m}^4$$

$$\phi_{AB} = \frac{T_{AB} L_{AB}}{G J_{AB}} = \frac{(200)(0.9)}{(77 \times 10^9)(79.522 \times 10^{-9})} = 29.396 \times 10^{-3} \text{ rad}$$

Rotation at A $\phi_A = \phi_B + \phi_{AB}$

$$= 36.745 \times 10^{-3} + 29.396 \times 10^{-3} \text{ rad} = 66.14 \times 10^{-3} \text{ rad}$$

$$= 3.79^\circ \quad \blacktriangleleft$$

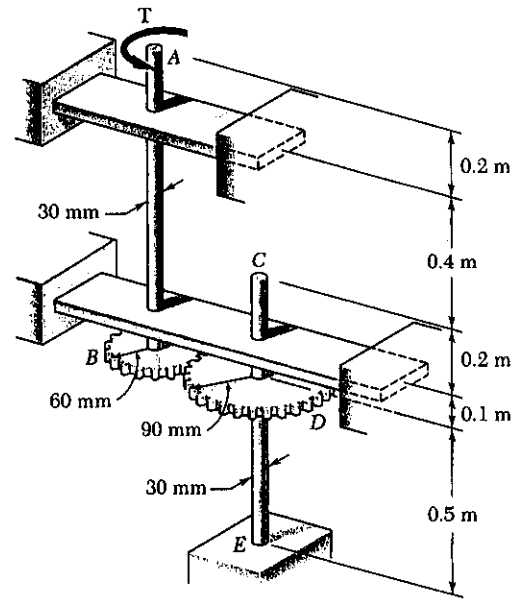

PROBLEM 3.155

3.155 The angle of rotation of end *A* of the gear-and-shaft system shown must not exceed 4° . Knowing that the shafts are made of a steel for which $\tau_{\text{all}} = 65 \text{ MPa}$ and $G = 77 \text{ GPa}$, determine the largest torque *T* which can be safely applied at end *A*.

SOLUTION

Calculation of torque ratio

Contact force *F*

$$F = \frac{T_{AB}}{r_B} = \frac{T_{DE}}{r_D}$$

$$T_{DE} = \frac{r_D}{r_B} T_{AB} = \frac{90}{60} T = 1.5 T$$

Since larger torque occurs in shaft, we find the torque limit based on stress in shaft DE

$$\tau = \frac{T_{DE} C}{J} = \frac{2 T_{DE}}{\pi C^3} = \frac{(2)(1.5) T}{\pi C^3}$$

$$T = \frac{\pi}{(2)(1.5)} C^3 \tau = \frac{\pi}{3} (0.015)^3 (65 \times 10^6) = 229.7 \text{ N}\cdot\text{m} \quad \triangleleft$$

Twist in shaft DE

$$J_{DE} = \frac{\pi}{2} C^4 = \frac{\pi}{2} (0.015)^4 = 79.522 \times 10^{-9} \text{ m}^4, \quad L_{DE} = 0.5 \text{ m}, \quad T_{DE} = 1.5 T$$

$$\phi_{DE} = \frac{T_{DE} L_{DE}}{G J_{DE}} = \frac{(1.5 T)(0.5)}{(77 \times 10^9)(79.522 \times 10^{-9})} = 122.485 \times 10^{-6} T$$

Rotation at D $\phi_D = 122.485 \times 10^{-6} T$

Circumferential displacement at gear circles $s = r_D \phi_D = r_B \phi_B$

Rotation at B $\phi_B = \frac{r_D}{r_B} \phi_D = \frac{90}{60} (122.485 \times 10^{-6} T) = 183.728 \times 10^{-6} T$

Twist in shaft AB: $L_{AB} = 0.1 + 0.2 + 0.4 + 0.2 = 0.9 \text{ m}$

$$\phi_{AB} = \frac{T_{AB} L_{AB}}{G J_{AB}} = \frac{T(0.9)}{(77 \times 10^9)(79.522 \times 10^{-9})} = 146.982 \times 10^{-6} T$$

Rotation at A $\phi_A = \phi_B + \phi_{AB} = 183.728 \times 10^{-6} T + 146.982 \times 10^{-6} T = 330.71 \times 10^{-6} T$

Rotation limit $\phi_A = 4^\circ = 69.813 \times 10^{-3} \text{ rad}$

Equating $330.71 \times 10^{-6} T = 69.813 \times 10^{-3} \therefore T = 211.1 \text{ N}\cdot\text{m}$

Limiting torque is the smaller value $T = 211 \text{ N}\cdot\text{m} \quad \blacktriangleleft$

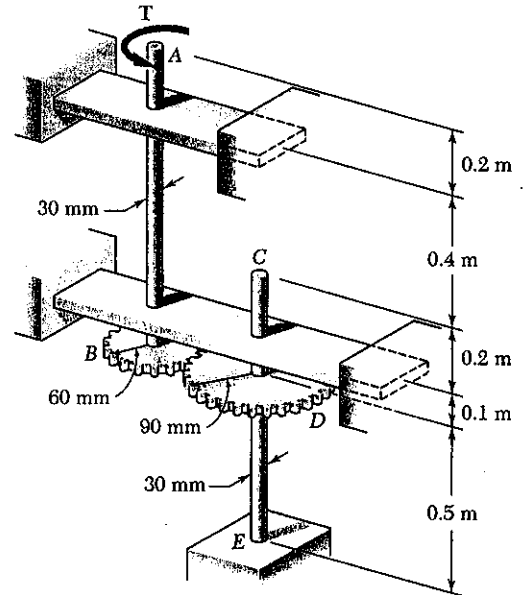

PROBLEM 3.156

3.156 A sheet metal strip of width 6 in. and 0.12 in. thickness is to be formed into a tube of rectangular cross section. Knowing that $\tau_{all} = 4$ ksi, determine the largest torque that may be applied to the tube when (a) $w = 1.5$ in., (b) $w = 1.2$ in., (c) $w = 1$ in.

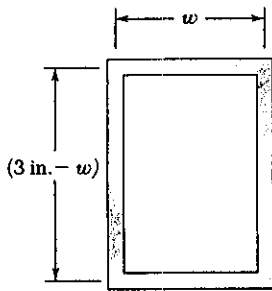

SOLUTION

perimeter $p = 6 \text{ in} = 2w + 2d$
 depth $d = \frac{p}{2} - w$

Area bounded by centerline $A = wd = w(\frac{p}{2} - w)$

$\tau = \frac{T}{2tA} \therefore T = 2tA\tau = 2tw(\frac{p}{2} - w)\tau$

Data: $t = 0.12 \text{ in}$, $p = 6 \text{ in}$, $\tau = 4 \text{ ksi}$

(a) $w = 1.5$ $T = (2)(0.12)(1.5)(1.5)(4) = 2.16 \text{ kip}\cdot\text{in}$ \blacktriangle

(b) $w = 1.2$ $T = (2)(0.12)(1.2)(1.3)(4) = 2.07 \text{ kip}\cdot\text{in}$ \blacktriangle

(c) $w = 1.0$ $T = (2)(0.12)(1.0)(2.0)(4) = 1.92 \text{ kip}\cdot\text{in}$ \blacktriangle

The largest allowable torque corresponds to a square section.

PROBLEM 3.157

3.157 Two solid brass rods AB and CD are brazed to a brass sleeve EF . Determine the ratio d_2/d_1 for which the same maximum shearing stress occurs in the rods and in the sleeve.

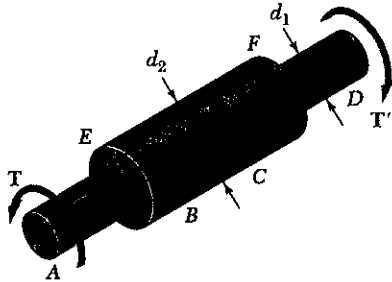

SOLUTION

Let $c_1 = \frac{1}{2}d_1$ and $c_2 = \frac{1}{2}d_2$

Shaft AB $\tau_1 = \frac{Tc_1}{J_1} = \frac{2T}{\pi c_1^3}$

Sleeve EF $\tau_2 = \frac{Tc_2}{J_2} = \frac{2Tc_2}{\pi(c_2^4 - c_1^4)}$

For equal stresses $\frac{2T}{\pi c_1^3} = \frac{2Tc_2}{\pi(c_2^4 - c_1^4)}$

$c_2^4 - c_1^4 = c_1^3 c_2$

Let $x = \frac{c_2}{c_1}$ $x^4 - 1 = x$ or $x = \sqrt[4]{1+x}$

Solve by successive approximations starting with $x_0 = 1.0$

$x_1 = \sqrt[4]{2} = 1.189$, $x_2 = \sqrt[4]{2.189} = 1.216$ $x_3 = \sqrt[4]{2.216} = 1.220$

$x_4 = \sqrt[4]{2.220} = 1.221$ $x_5 = \sqrt[4]{2.221} = 1.221$ (converged)

$x = 1.221$ $\frac{c_2}{c_1} = \frac{d_2}{d_1} = 1.221$ \blacktriangle

PROBLEM 3.158

3.158 One of the two hollow steel drive shafts of an ocean liner is 75 m long and has the cross section shown. knowing that $G = 77$ GPa and that the shaft transmits 44 MW to its propeller when rotating at 144 rpm, determine (a) the maximum shearing stress in the shaft, (b) the angle of twist of the shaft.

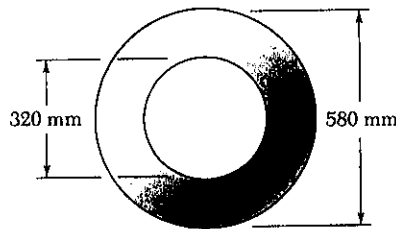
**SOLUTION**

$$L = 75 \text{ m}, \quad f = 144 \text{ rpm} = \frac{144}{60} = 2.4 \text{ Hz}$$

$$P = 44 \text{ MW} = 44 \times 10^6 \text{ W}$$

$$P = 2\pi f T \therefore T = \frac{P}{2\pi f} = \frac{44 \times 10^6}{2\pi(2.4)} = 2.9178 \times 10^6 \text{ N}\cdot\text{m}$$

$$c_1 = \frac{d_1}{2} = \frac{320}{2} = 160 \text{ mm} = 0.160 \text{ m}$$

$$c_2 = \frac{d_2}{2} = \frac{580}{2} = 290 \text{ mm} = 0.290 \text{ m}$$

$$J = \frac{\pi}{2}(c_2^4 - c_1^4) = \frac{\pi}{2}(0.290^4 - 0.160^4) = 10.08 \times 10^{-3} \text{ m}^4$$

$$(a) \quad \tau = \frac{Tc_2}{J} = \frac{(2.9178 \times 10^6)(0.290)}{10.08 \times 10^{-3}} = 83.9 \times 10^6 \text{ Pa} = 83.9 \text{ MPa}$$

$$(b) \quad \phi = \frac{TL}{GJ} = \frac{(2.9178 \times 10^6)(75)}{(77 \times 10^9)(10.08 \times 10^{-3})} = 281.9 \times 10^{-3} \text{ rad} = 16.15^\circ$$

www.iepnu.ir



PROBLEM 3.159

3.159 The shaft AB is made of a material which is elastoplastic with $\tau_y = 12.5$ ksi and $G = 4 \times 10^6$ psi. For the loading shown, determine (a) the radius of the elastic core of the shaft, (b) the angle of twist at end B .

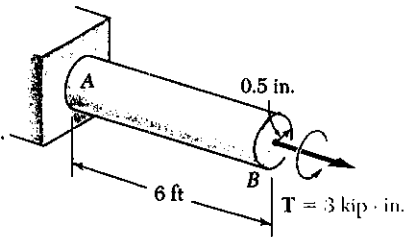

SOLUTION

$$c = 0.5 \text{ in}$$

$$T_Y = \frac{J\tau_y}{c} = \frac{\pi}{2} c^3 \tau_y = \frac{\pi}{2} (0.5)^3 (12.5) = 2.454 \text{ kip-in}$$

$$T = 3 \text{ kip-in} > T_Y \quad \text{plastic region with elastic core}$$

$$T = \frac{4}{3} T_Y \left(1 - \frac{1}{4} \frac{\rho_r^3}{c^3}\right) \therefore \frac{\rho_r^3}{c^3} = 4 - \frac{3T}{T_Y} = 4 - \frac{(3)(2.454)}{3} = 0.33307$$

$$\frac{\rho_r}{c} = 0.69318$$

$$\rho_r = (0.69318)(0.5) = 0.347 \text{ in.}$$

$$L = 6 \text{ ft} = 72 \text{ in.}$$

$$G = 4 \times 10^6 \text{ psi} = 4 \times 10^3 \text{ ksi}$$

$$\phi_Y = \frac{T_Y L}{JG} = \frac{2T_Y L}{\pi c^4 G} = \frac{(2)(2.454)(72)}{\pi (0.5)^4 (4 \times 10^3)} = 0.4499 \text{ rad}$$

$$\frac{\phi_r}{\phi} = \frac{\rho_r}{c} \therefore \phi = \frac{\phi_r}{\rho_r/c} = \frac{0.4499}{0.69318} = 0.64904 \text{ rad} = 37.2^\circ$$

PROBLEM 3.160

3.160 If the 3 kip-in. torque applied to the shaft of Prob. 3.159 is removed, determine (a) the magnitude and location of the maximum residual shearing stress in the shaft, (b) the permanent angle of twist of the shaft.

SOLUTION

From the solution of PROBLEM 3.159, at the end of loading $T = 3$ kip-in

$$\frac{\rho_r}{c} = 0.69318, \quad \phi_{\text{load}} = 0.64904 \text{ rad}$$

Stresses $\tau = 0$ at $\rho = 0$, $\tau = 12.5$ ksi at $\rho = \rho_r$, $\tau = 12.5$ ksi at $\rho = c$.

Unloading $T = -3$ kip-in. $G = 4 \times 10^6$ psi = 4×10^3 ksi

$$\Delta\tau = \frac{T\rho}{J} = \frac{2T\rho}{\pi c^3} = \frac{(2)(-3)}{\pi (0.5)^3} = -15.28 \text{ ksi at } \rho = c$$

$$\Delta\tau = (0.69318)(-15.28) = 10.59 \text{ ksi at } \rho = \rho_r.$$

$$\Delta\phi = \frac{TL}{GJ} = \frac{2TL}{\pi c^4 G} = \frac{(2)(-3)(72)}{\pi (0.5)^4 (4 \times 10^3)} = -0.55004 \text{ rad.}$$

Residual $\tau_{\text{res}} = \tau_{\text{load}} + \Delta\tau$

$$\text{At } \rho = c \quad \tau_{\text{res}} = 12.5 - 15.28 = -2.78 \text{ ksi}$$

$$\text{At } \rho = \rho_r \quad \tau_{\text{res}} = 12.5 - 10.59 = 1.91 \text{ ksi}$$

$$\phi_{\text{perm}} = \phi_{\text{load}} + \Delta\phi = 0.64904 - 0.55004 = 0.099 \text{ rad} = 5.67^\circ$$

PROBLEM 3.161

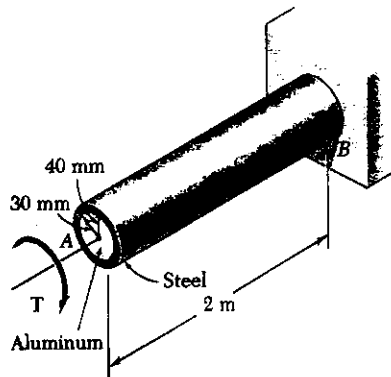

3.161 The composite shaft shown is twisted by applying a torque T at end A . Knowing that the maximum shearing stress in the steel shell is 150 MPa, determine the corresponding maximum shearing stress in the aluminum core. Use $G = 77$ GPa for steel and $G = 27$ GPa for aluminum.

SOLUTION

Let G_1 , J_1 , and τ_1 refer to the aluminum core.
and G_2 , J_2 , and τ_2 refer to the steel shell

At the outer surface on the steel shell

$$\gamma_2 = \frac{C_2 \phi}{L} \therefore \frac{\phi}{L} = \frac{\gamma_2}{C_2} = \frac{\tau_2}{C_2 G_2}$$

At the outer surface of the aluminum core

$$\gamma_1 = \frac{C_1 \phi}{L} \therefore \frac{\phi}{L} = \frac{\gamma_1}{C_1} = \frac{\tau_1}{C_1 G_1}$$

Matching $\frac{\phi}{L}$ for both components

$$\frac{\tau_2}{C_2 G_2} = \frac{\tau_1}{C_1 G_1}$$

Solving for τ_2

$$\begin{aligned} \tau_2 &= \frac{C_2}{C_1} \cdot \frac{G_2}{G_1} \tau_1 \\ &= \frac{0.030}{0.040} \cdot \frac{27 \times 10^9}{77 \times 10^9} \cdot 150 \times 10^6 \\ &= 39.4 \times 10^6 \text{ Pa} \end{aligned}$$

$$= 39.4 \text{ MPa} \blacktriangleleft$$

PROBLEM 3.C1

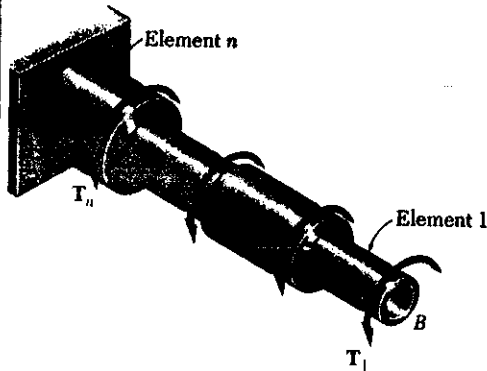

3.C1 Shaft *AB* consists of *n* homogeneous cylindrical elements, which can be solid or hollow. Its end *A* is fixed, while its end *B* is free, and it is subjected to the loading shown. The length of element *i* is denoted by L_i , its outer diameter by OD_i , its inner diameter by ID_i , its modulus of rigidity by G_i , and the torque applied to its right end by T_i , the magnitude T_i of this torque being assumed to be positive if T_i is observed as counterclockwise from end *B* and negative otherwise. (Note that $ID_i = 0$ if the element is solid.) (a) Write a computer program that can be used to determine the maximum shearing stress in each element, the angle of twist of each element, and the angle of twist of the entire shaft. (b) Use this program to solve Probs. 3.9, 3.35, 3.37, 3.150, and 3.151.

SOLUTION

FOR EACH CYLINDRICAL ELEMENT, ENTER

$$L_i, OD_i, ID_i, G_i, T_i$$

AND COMPUTE

$$J_i = (\pi/32)(OD_i^4 - ID_i^4)$$

OUTLINE OF PROGRAM

UPDATE TORQUE $T = T + T_i$

AND COMPUTE

$$\tau_{max,i} = T (OD_i/2) / J_i$$

$$\phi_i = T L_i / G_i J_i$$

ANGLE OF TWIST OF ENTIRE SHAFT, STARTING WITH $\Theta = 0$, UPDATE THROUGH n^{th} ELEMENT

$$\Theta = \Theta + \phi_i$$

PROGRAM OUTPUT

Problem	3.9 and 3.35		
Element	Maximum Stress (MPa)	Angle of Twist (degrees)	
1.0000	56.5884	2.5265	
2.0000	36.6264	0.8887	
Angle of twist for entire shaft =			3.4152 °

Problem	3.37		
Element	Maximum Stress (MPa)	Angle of Twist (degrees)	
1.0000	33.9531	0.8314	
2.0000	19.6488	0.7413	
Angle of twist for entire shaft =			1.5726 °

Problem	3.150 and 3.151		
Element	Maximum Stress (ksi)	Angle of Twist (degrees)	
1.0000	9.1266	3.5857	
2.0000	-8.5526	-3.0002	
Angle of twist for entire shaft =			0.5855 °

PROBLEM 3.C2

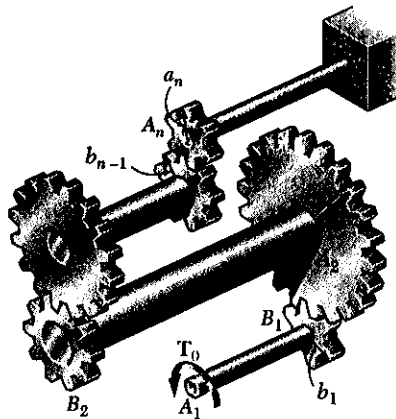

3.C2 The assembly shown consists of n cylindrical shafts, which can be solid or hollow, connected by gears and supported by brackets (not shown). End A_1 of the first shaft is free and is subjected to a torque T_0 , while end B_n of the last shaft is fixed. The length of shaft $A_i B_i$ is denoted by L_i , its outer diameter by OD_i , its inner diameter by ID_i , and its modulus of rigidity by G_i . (Note that $ID_i = 0$ if the element is solid.) The radius of gear A_i is denoted by a_i , and the radius of gear B_i by b_i . (a) Write a computer program that can be used to determine the maximum shearing stress in each shaft, the angle of twist of each shaft, and the angle through which end A_i rotates. (b) Use this program to solve Probs. 3.21, 3.39, 3.41, 3.42, and 3.154.

SOLUTION

TORQUE IN SHAFTS. ENTER $T_L = T_0$

$$T_{L+1} = T_L (A_{L+1} / B_L)$$

FOR EACH SHAFT, ENTER

L_i OD_i ID_i G_i

COMPUTE: $J_i = (\pi/32)(OD_i^4 - ID_i^4)$

$$\tau_{L_i} = T_L (OD_i / 2) / J_i$$

$$\phi_{L_i} = T_L L_i / G_i J_i$$

ANGLE OF ROTATION AT END A_i

COMPUTE ROTATION AT THE "A" END OF EACH SHAFT

START WITH ANGLE = ϕ_{L_n} AND UPDATE

FROM n TO 1, AND ADD ϕ_{L_i}

$$\text{ANGLE} = \text{ANGLE}(A_i) / B_{L_i-1} + \phi_{L_i-1}$$

PROGRAM OUTPUT

Problem 3.21

Shaft No.	Max.Stress (MPa)	Twist Angle (degrees)
1.0000	68.7420	1.4615
2.0000	72.5013	0.7707
Angle through which A1 rotates = 3.388 °		

Problem 3.39

Shaft No.	Max.Stress (MPa)	Twist Angle (degrees)
1.0000	47.7465	1.7764
2.0000	82.8932	2.0560
Angle through which A1 rotates = 7.945 °		

Problem 3.41

Shaft No.	Max.Stress (ksi)	Twist Angle (degrees)
1.0000	9.0541	1.3587
2.0000	12.0722	1.3175
Angle through which A1 rotates = 3.115 °		

Problem 3.42

Shaft No.	Max.Stress (ksi)	Twist Angle (degrees)
1.0000	9.0541	1.3587
2.0000	6.7906	0.7411
Angle through which A1 rotates = 1.914 °		

Problem 3.154

Shaft No.	Max.Stress (MPa)	Twist Angle (degrees)
1.0000	37.7256	1.6843
2.0000	56.5884	1.4036
Angle through which A1 rotates = 3.790 °		

PROBLEM 3.C3

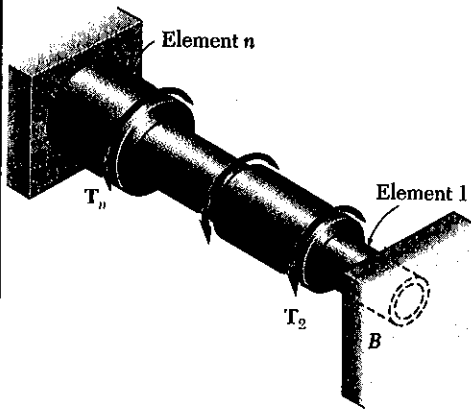

3.C3 Shaft AB consists of n homogeneous cylindrical elements, which can be solid or hollow. Both of its ends are fixed, and it is subjected to the loading shown. The length of element i is denoted by L_i , its outer diameter by OD_i , its inner diameter by ID_i , its modulus of rigidity by G_i , and the torque applied to its right end by T_i , the magnitude T_i of this torque being assumed to be positive if T_i is observed as counterclockwise from end B and negative otherwise. Note that $ID_i = 0$ if the element is solid and also that $T_1 = 0$. Write a computer program that can be used to determine the reactions at A and B, the maximum shearing stress in each element, and the angle of twist of each element. Use this program (a) to solve Prob. 3.56, (b) to determine the maximum shearing stress in the shaft of Example 3.05.

SOLUTION WE CONSIDER THE REACTION AT B AS REDUNDANT AND RELEASE THE SHAFT AT B. COMPUTE Θ_B WITH $T_B = 0$:

FOR EACH ELEMENT ENTER $L_i, OD_i, ID_i, G_i, T_i$ (NOTE $T_1 = T_B = 0$)

COMPUTE

$$J_i = (\pi/32)(OD_i^4 - ID_i^4)$$

UPDATE TORQUE

$$T = T + T_i$$

AND COMPUTE FOR EACH ELEMENT

$$\tau_{iL} = T(OD_i/2)/J_i$$

$$\phi_{iL} = T L_i / G_i J_i$$

COMPUTE Θ_B : STARTING WITH $\Theta = 0$ AND UPDATING THROUGH n ELEMENTS

$$\Theta_i = \Theta_i + \phi_{iL} \quad ; \quad \Theta_B = \Theta_n$$

COMPUTE Θ_B DUE TO UNIT TORQUE AT B

$$\text{UNIT } \tau_{iL} = OD_i / 2 J_i$$

$$\text{UNIT } \phi_{iL} = L_i / G_i J_i$$

FOR n ELEMENTS:

$$\text{UNIT } \Theta_B(L) = \text{UNIT } \phi_{iL} + \text{UNIT } \tau_{iL}$$

SUPERPOSITION:

FOR TOTAL ANGLE AT B TO BE ZERO. $\Theta_B + T_B(\text{UNIT } \Theta_B(n)) = 0$

$$T_B = -\Theta_B / (\text{UNIT } \Theta_B(n))$$

THEN $T_A = \sum T(L) + T_B$

FOR EACH ELEMENT: MAX STRESS: TOTAL $\tau_{iL} = \tau_{iL} + T_B(\text{UNIT } \tau_{iL})$
 ANGLE OF TWIST: TOTAL $\phi_{iL} = \phi_{iL} + T_B(\text{UNIT } \phi_{iL})$

PROGRAM OUTPUT

Problem 3.56		TA =	-0.290 kN*m
		TB =	-0.210 kN*m
Element	tau max (MPa)	Angle of Twist (degrees)	
1	-39.588		-1.178
2	31.670		1.178

Problem 3.05		TA =	-51.733 lb*ft
		TB =	-38.267 lb*ft

PROBLEM 3.C4

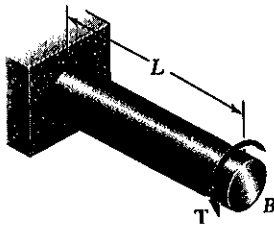

3.C4 The homogeneous, solid cylindrical shaft *AB* has a length *L*, a diameter *d*, a modulus of rigidity *G*, and a yield strength τ_y . It is subjected to a torque *T* that is gradually increased from zero until the angle of twist of the shaft has reached a maximum value ϕ_m and then decreased back to zero. (a) Write a computer program that, for each of 16 values of ϕ_m equally spaced over a range extending from 0 to a value 3 times as large as the angle of twist at the onset of yield, can be used to determine the maximum value T_m of the torque, the radius of the elastic core, the maximum shearing stress, the permanent twist, and the residual shearing stress both at the surface of the shaft and at the interface of the elastic core and the plastic region. (b) Use this program to obtain approximate answers to Probs. 3.95, 3.113, 3.159, and 3.160.

SOLUTION

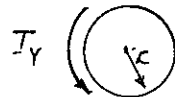

AT ONSET OF YIELD

$$T_Y = \tau_Y \frac{J}{c} = \frac{\pi}{2} \tau_Y c^3$$

$$\phi_Y = \frac{T_Y L}{GJ} = \left(\frac{\tau_Y J}{c} \right) \frac{L}{GJ} = \frac{\tau_Y L}{cG}$$

LOADING: $T_m > T_Y$

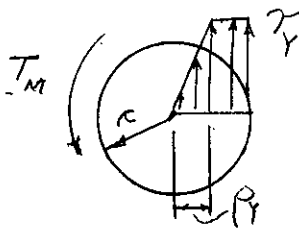

$$T_m = \frac{4}{3} T_Y \left[1 - \frac{1}{4} \left(\frac{\phi_Y}{\phi_m} \right)^3 \right] \quad \text{EQ. (1)}$$

$$\rho_Y = c \frac{\phi_Y}{\phi_m} \quad \text{EQ. (2)}$$

UNLOADING (ELASTIC)

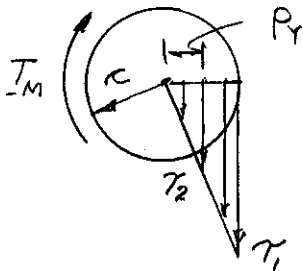

$$\phi_U = \frac{T_m L}{GJ}$$

$\phi_U =$ ANGLE OF TWIST FOR UNLOADING

$$\tau_1 = T_m \frac{c}{J}$$

$\tau_1 =$ TAU AT $\rho = c$

$$\tau_2 = \tau_1 \frac{\rho_Y}{c}$$

$\tau_2 =$ TAU AT $\rho = \rho_Y$

SUPERPOSE LOADING AND UNLOADING

FOR $\phi = 0$ TO $\phi = 3\phi_Y$ USING $0.2\phi_Y$ INCREMENTS

WHEN $\phi < \phi_Y$: $T_m = \tau_Y \frac{\phi}{\phi_Y}$ $\rho_Y = \frac{1}{2}d$ $\phi_m = \phi_Y \frac{\phi}{\phi_Y}$

WHEN $\phi > \phi_Y$: T_m USE EQ.(1) ρ_Y USE EQ.(2)

RESIDUAL: $\phi_p = \phi_m - \phi_U$ $\tau_{R2} = \tau_1 - \tau_Y$ $\tau_{R1} = \tau_2 - \tau_Y$

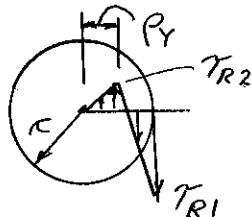

CONTINUED

PROBLEM 3.C4 - CONTINUED

INTERPOLATE BETWEEN VALUES AT VALUES OF T_M INDICATED. ↓

Problem 3.95		RY in.	TAUM ksi	PHIP deg	TAUR1 ksi	TAUR2 ksi
PHIM deg	TM kip*in.					
0.000	0.000	0.750	0.000	0.000	0.000	0.000
0.417	2.783	0.750	4.200	0.000	0.000	0.000
0.833	5.567	0.750	8.400	0.000	0.000	0.000
1.250	8.350	0.750	12.600	0.000	0.000	0.000
1.667	11.133	0.750	16.800	0.000	0.000	0.000
2.083	13.916	0.750	21.000	0.000	0.000	0.000
2.500	15.871	0.625	21.000	0.124	1.042	-2.949
2.917	16.865	0.536	21.000	0.392	2.822	-4.449
3.334	17.423	0.469	21.000	0.725	4.568	-5.291
3.750	17.760	0.417	21.000	1.091	6.111	-5.800
4.167	17.975	0.375	21.000	1.476	7.438	-6.125
4.584	18.119	0.341	21.000	1.871	8.572	-6.343
5.000	18.219	0.313	21.000	2.273	9.544	-6.494
5.417	18.291	0.288	21.000	2.679	10.384	-6.602
5.834	18.344	0.268	21.000	3.087	11.114	-6.681
6.250	18.383	0.250	21.000	3.498	11.753	-6.741

← $T_M = 12$ kip.in.

← $T_M = 18$ kip.in.

Problem 3.113		RY mm	TAUM MPa	PHIP deg	TAUR1 MPa	TAUR2 MPa
PHIM deg	TM kN*m					
0.000	0.000	25.000	0.000	0.000	0.000	0.000
9.524	0.785	25.000	32.000	0.000	0.000	0.000
19.049	1.571	25.000	64.000	0.000	0.000	0.000
28.573	2.356	25.000	96.000	0.000	0.000	0.000
38.098	3.142	25.000	128.000	0.000	0.000	0.000
47.622	3.927	25.000	160.000	0.000	0.000	0.000
57.147	4.713	20.833	160.000	2.837	7.942	-22.469
66.671	4.759	17.857	160.000	8.960	21.502	-33.897
76.196	4.916	15.625	160.000	16.575	34.805	-40.313
85.720	5.012	13.889	160.000	24.946	46.562	-44.188
95.245	5.072	12.500	160.000	33.733	56.667	-46.667
104.769	5.113	11.364	160.000	42.764	65.307	-48.325
114.294	5.141	10.417	160.000	51.946	72.719	-49.475
123.818	5.162	9.615	160.000	61.225	79.116	-50.299
133.343	5.176	8.929	160.000	70.569	84.677	-50.904
142.867	5.188	8.333	160.000	79.959	89.547	-51.358

← $T_M = 5$ kN.m

Problems 3.159 and 3.160		RY in.	TAUM ksi	PHIP deg	TAUR1 ksi	TAUR2 ksi
PHIM deg	TM kip*in.					
0.000	0.000	0.500	0.000	0.000	0.000	0.000
5.157	0.491	0.500	2.500	0.000	0.000	0.000
10.313	0.982	0.500	5.000	0.000	0.000	0.000
15.470	1.473	0.500	7.500	0.000	0.000	0.000
20.626	1.963	0.500	10.000	0.000	0.000	0.000
25.783	2.454	0.500	12.500	0.000	0.000	0.000
30.940	2.799	0.417	12.500	1.536	0.620	-1.755
36.096	2.974	0.357	12.500	4.851	1.680	-2.648
41.253	3.073	0.313	12.500	8.974	2.719	-3.149
46.410	3.132	0.278	12.500	13.506	3.638	-3.452
51.566	3.170	0.250	12.500	18.263	4.427	-3.646
56.723	3.196	0.227	12.500	23.152	5.102	-3.775
61.879	3.213	0.208	12.500	28.124	5.681	-3.865
67.036	3.226	0.192	12.500	33.148	6.181	-3.930
72.193	3.235	0.179	12.500	38.207	6.615	-3.977
77.349	3.242	0.167	12.500	43.290	6.996	-4.012

← $T_M = 3$ kip.in.

PROBLEM 3.C5

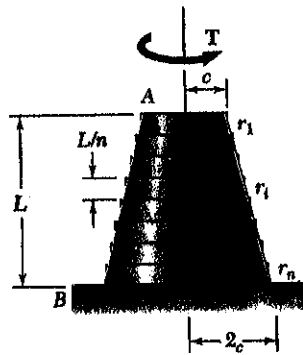
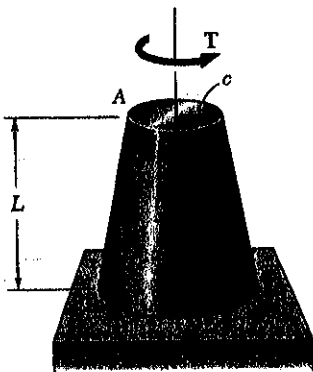

3.C5 The exact expression is given in Prob. 3.64 for the angle of twist of the solid tapered shaft *AB* when a torque *T* is applied as shown. Derive an approximate expression for the angle of twist by replacing the tapered shaft by *n* cylindrical shafts of equal length and of radius $r_i = (n + i - \frac{1}{2})(c/n)$, where $i = 1, 2, \dots, n$. Using for *T*, *L*, *G*, and *c* values of your choice, determine the percentage error in the approximate expression when (a) $n = 4$, (b) $n = 8$, (c) $n = 20$, (d) $n = 100$.

SOLUTION

FROM PROB. 3.64 EXACT EXPRESSION:

$$\phi = \frac{7TL}{12\pi Gc^4}$$

OR, $\phi = \left(\frac{7}{12\pi}\right) \frac{TL}{Gc^4} = 0.18568 \frac{TL}{Gc^4}$

CONSIDER TYPICAL *i*th SHAFT

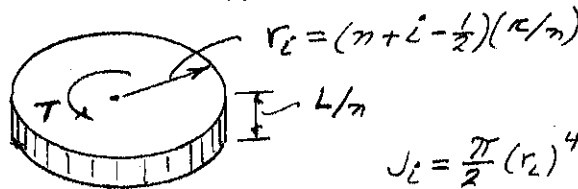

$$r_i = (n + i - \frac{1}{2})(c/n)$$

$$J_i = \frac{\pi}{2} (r_i)^4$$

$$\Delta\phi = \frac{T(L/n)}{GJ_i}$$

ENTER UNIT VALUES OF T, L, G, AND c.
 (NOTE: SPECIFIC VALUES CAN BE ENTERED)

ENTER INITIAL VALUE OF ZERO FOR ϕ
ENTER n = NUMBER CYLINDRICAL SHAFTS

FOR $i = 1$ TO n , UPDATE ϕ

$$\phi = \phi + \Delta\phi$$

OUTPUT OF PROGRAM

COEFFICIENT of TL/Gc^4

Exact coefficient from Prob. 3.64 is 0.18568
 Number of elemental disks = n

n	approximate	exact	percent error
4	0.17959	0.18568	-3.28185
8	0.18410	0.18568	-0.85311
20	0.18542	0.18568	-0.13810
100	0.18567	0.18568	-0.00554

PROBLEM 3.C6

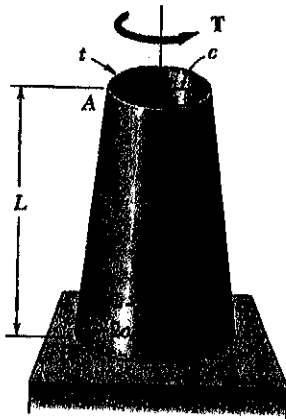

3.C6 A torque T is applied as shown to the long, hollow, tapered shaft AB of uniform thickness t . The exact expression for the angle of twist of the shaft can be obtained from the expression given in Prob. 3.153. Derive an approximate expression for the angle of twist by replacing the tapered shaft by n cylindrical rings of equal length and of radius $r_i = (n + i - \frac{1}{2})(c/n)$, where $i = 1, 2, \dots, n$. Using for T, L, G, c and t values of your choice, determine the percentage error in the approximate expression when (a) $n = 4$, (b) $n = 8$, (c) $n = 20$, (d) $n = 100$.

SOLUTION

SINCE THE SHAFT IS LONG $c \ll L$, THE ANGLE θ IS SMALL AND WE CAN USE t AS THE THICKNESS OF THE n CYLINDRICAL RINGS.

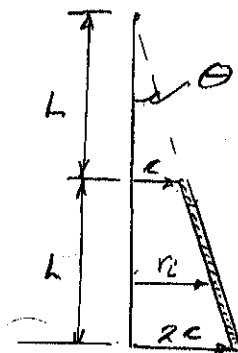

FOR $c \ll L$

$$\theta \approx \tan \theta = \frac{2c - c}{L} = \frac{c}{L}$$

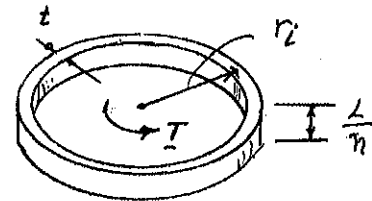

$$r_i = (n + i - \frac{1}{2}) \left(\frac{c}{n} \right)$$

$$J_i \approx (\text{AREA}) r_i^2 = (2\pi r_i t) r_i^2 = 2\pi t r_i^3$$

$$\Delta \phi = \frac{T(L/n)}{G J_i}$$

ENTER UNIT VALUES FOR T, L, G, t , AND n

(NOTE: SPECIFIC VALUES CAN BE ENTERED IF DESIRED)

ENTER INITIAL VALUE OF ZERO FOR ϕ

ENTER n = NUMBER OF CYLINDRICAL RINGS

FOR $i = 1$ TO n , UPDATE ϕ

$$\phi = \phi + \Delta \phi$$

OUTPUT OF PROGRAM

COEFFICIENT of TL/Gtc^3

Exact coefficient from Prob. 3.153 is 0.05968
Number of elemental disks = n

n	approximate	exact	percent error
4	0.058559	0.059683	-1.883078
8	0.059394	0.059683	-0.483688
20	0.059637	0.059683	-0.078022
100	0.059681	0.059683	-0.003127